



ENGLISH

FRANÇAIS

DEUTSCH

NEDERLANDS

ITALIANO

PORT DO BRASIL

ESPAÑOL

ΕΛΛΗΝΙΚΑ



PIXMA MX525 series

1

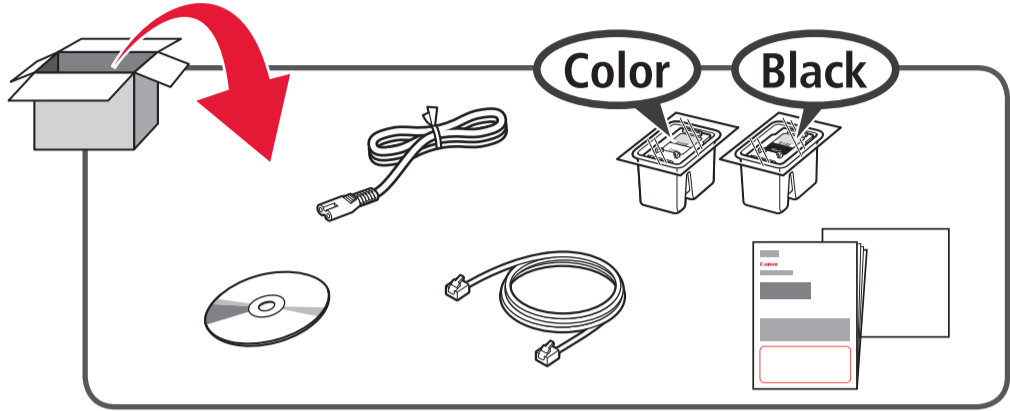

2

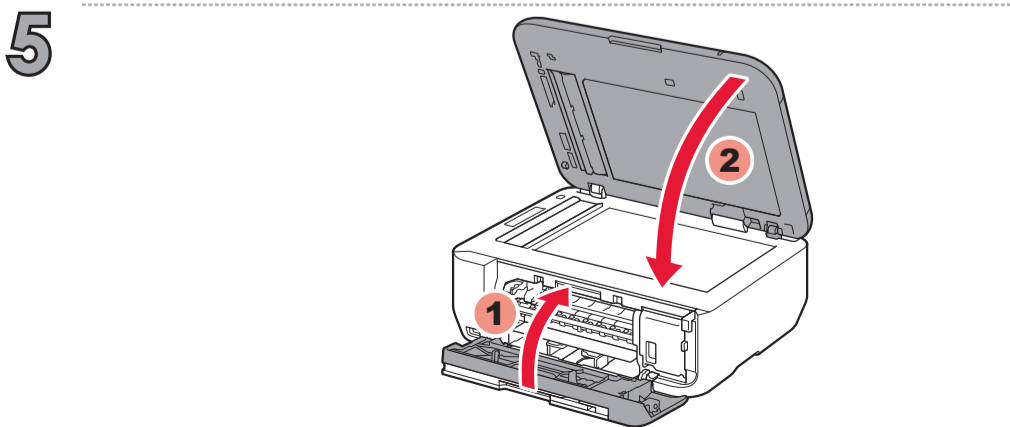
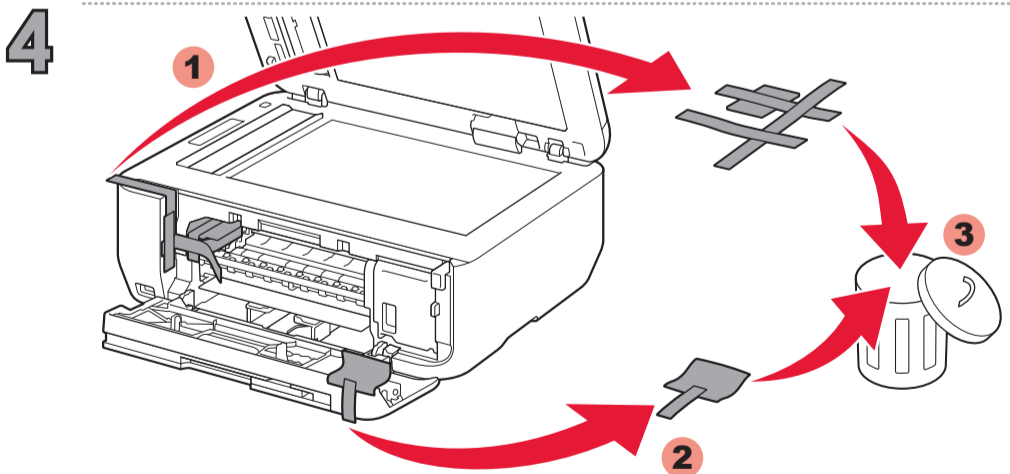
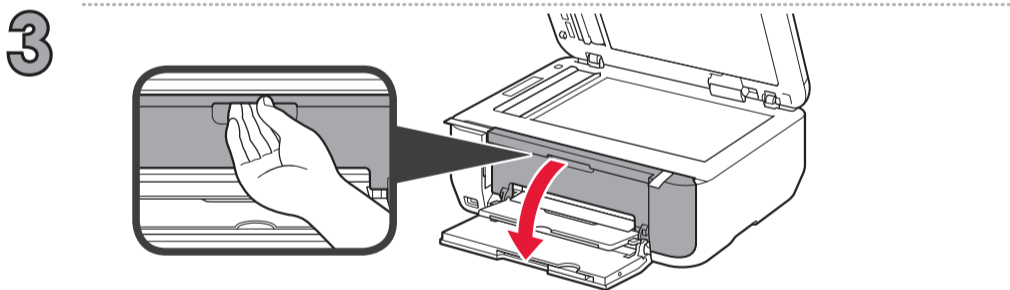
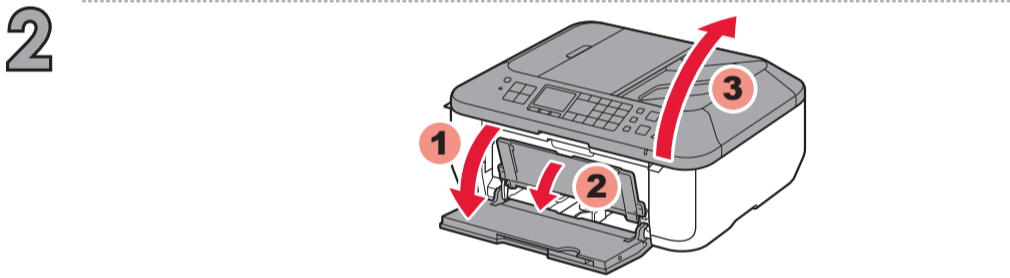
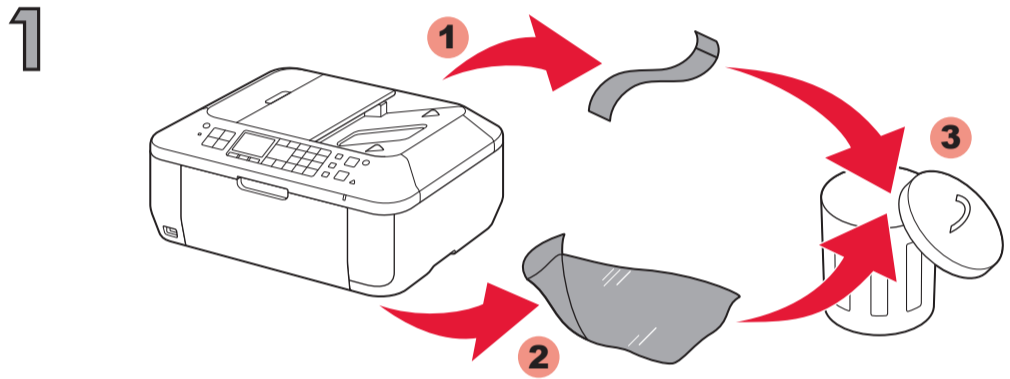

3

1

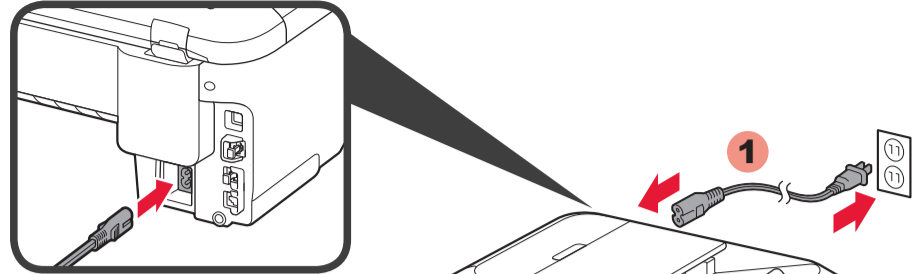

2

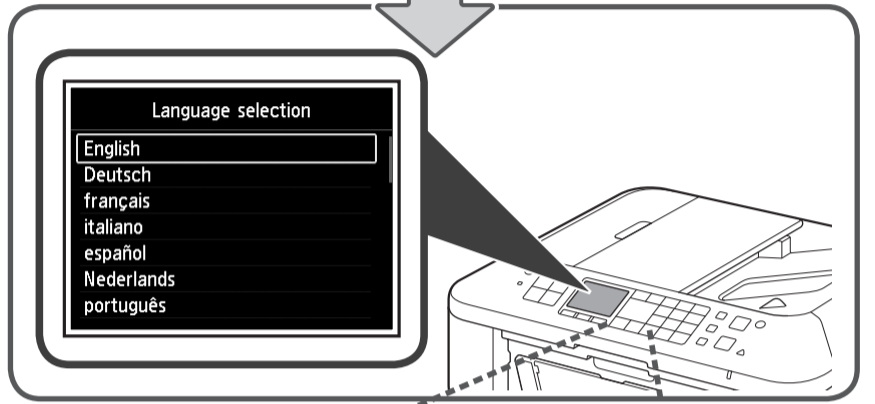
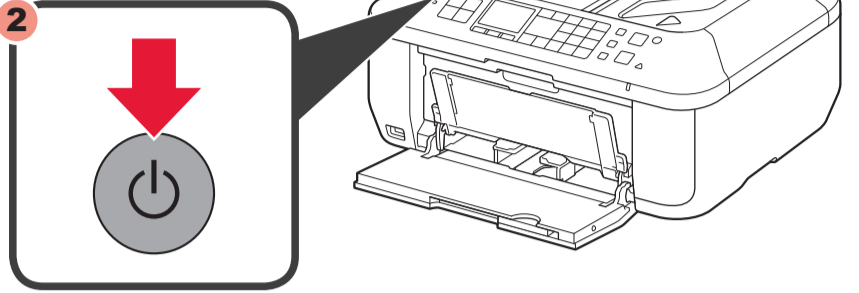

2

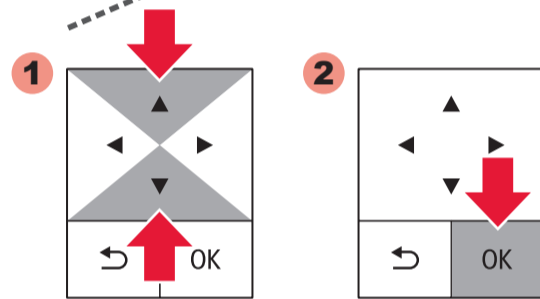

3

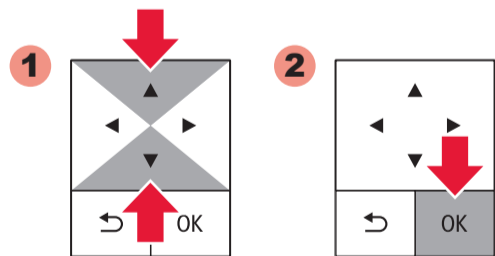
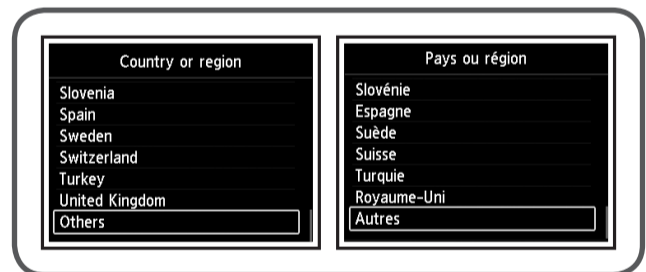

4

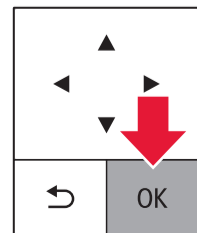
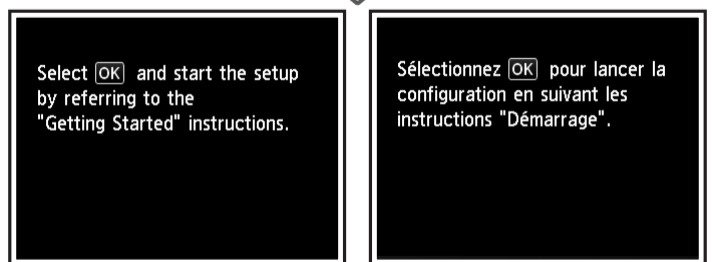

4

1

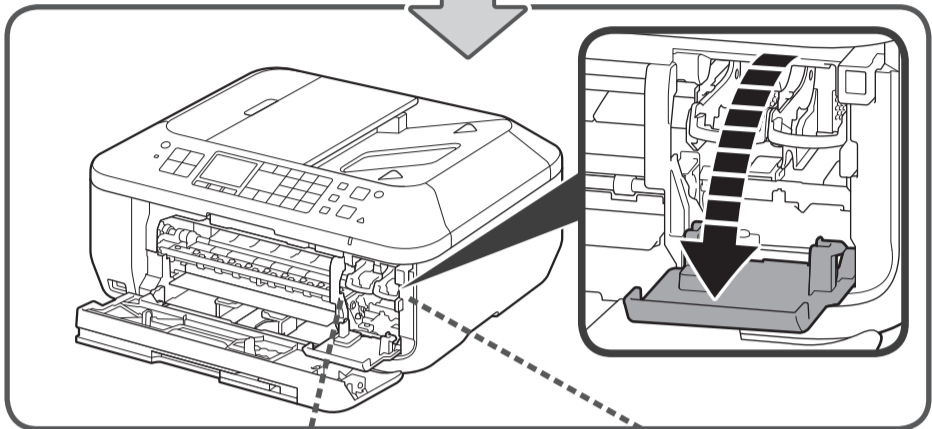
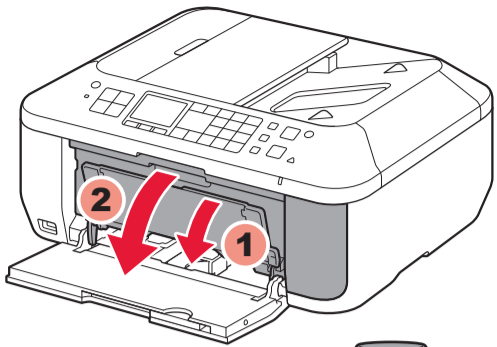

2

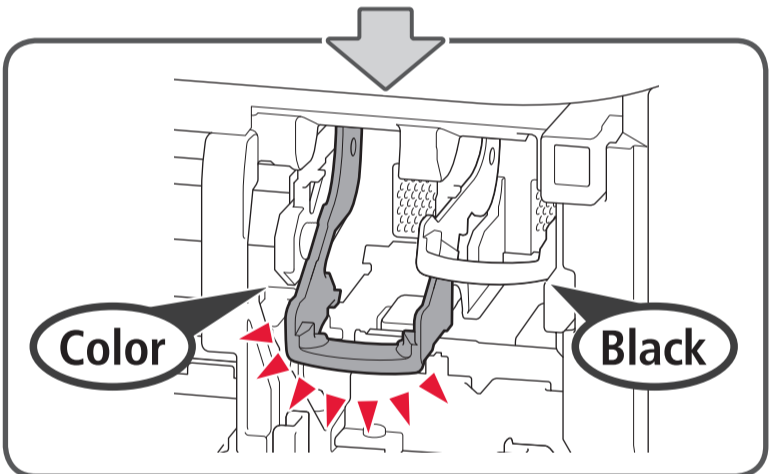
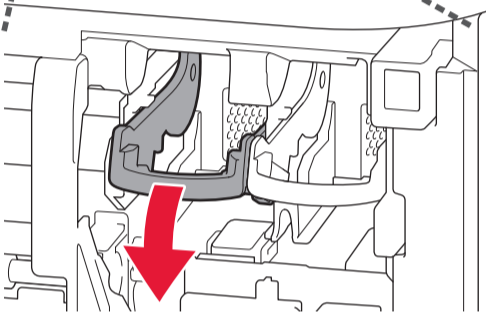

3

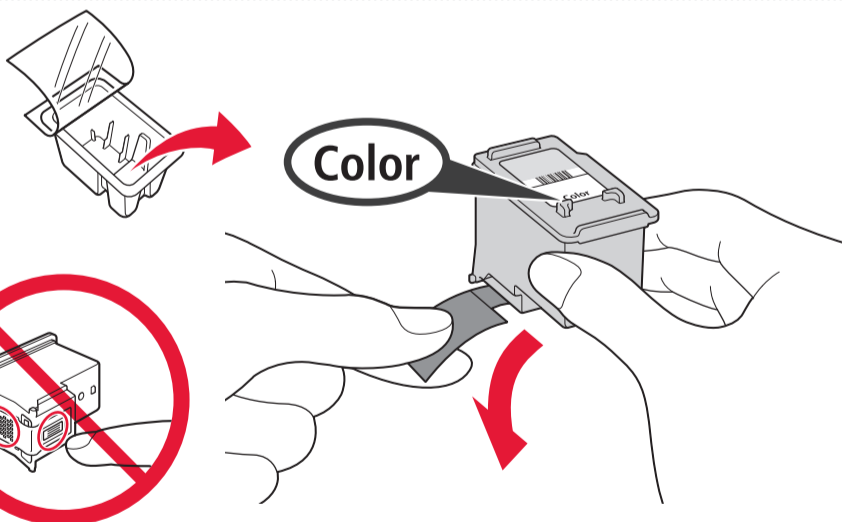

4

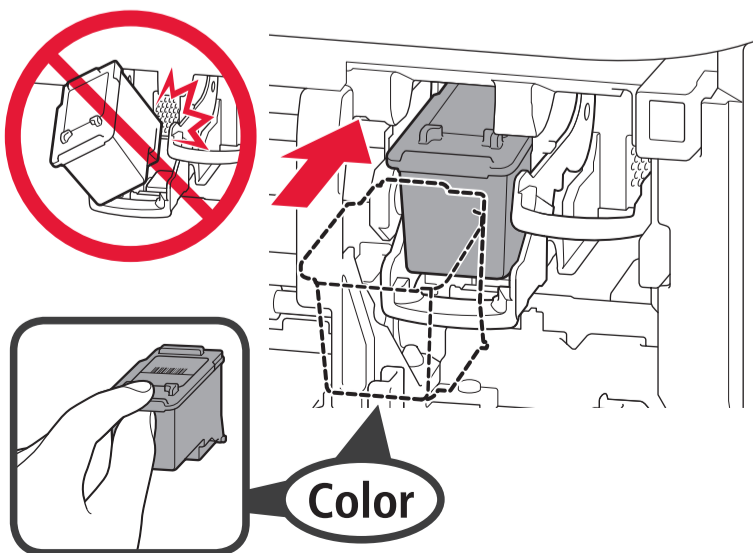

5

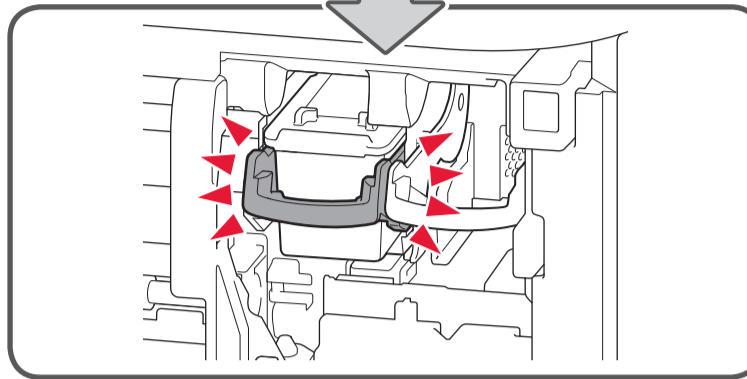
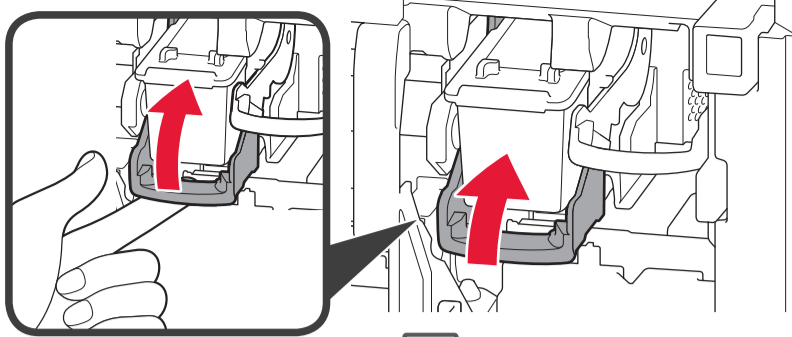

6

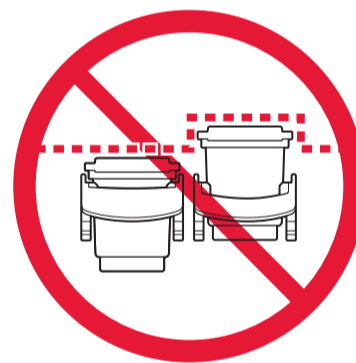
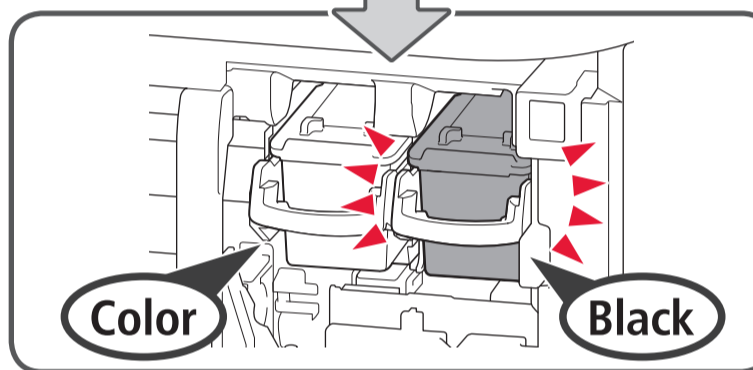
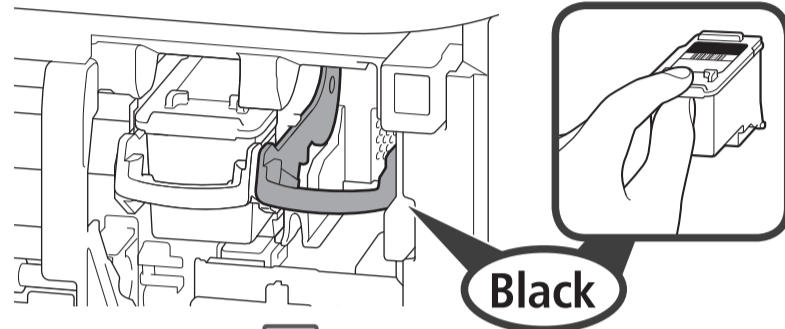

7

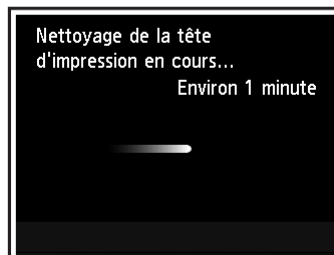
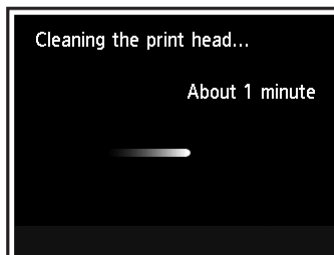
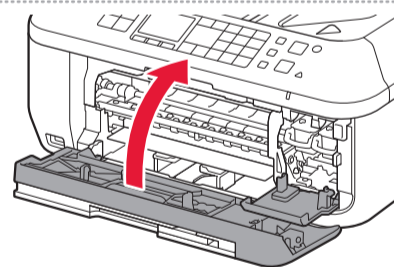

00:02:00

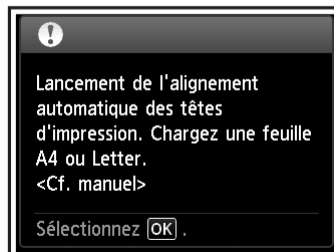
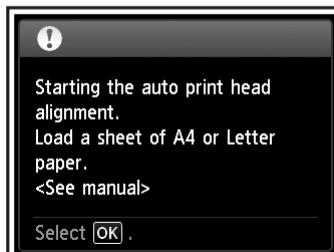

5

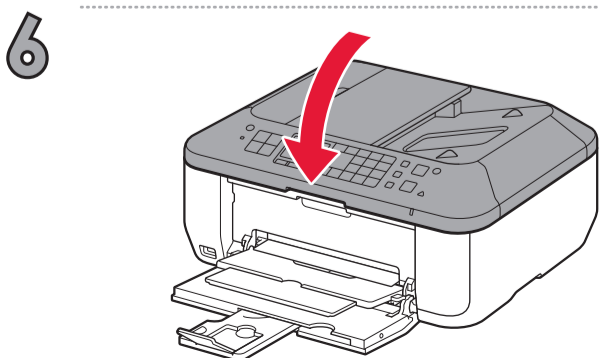
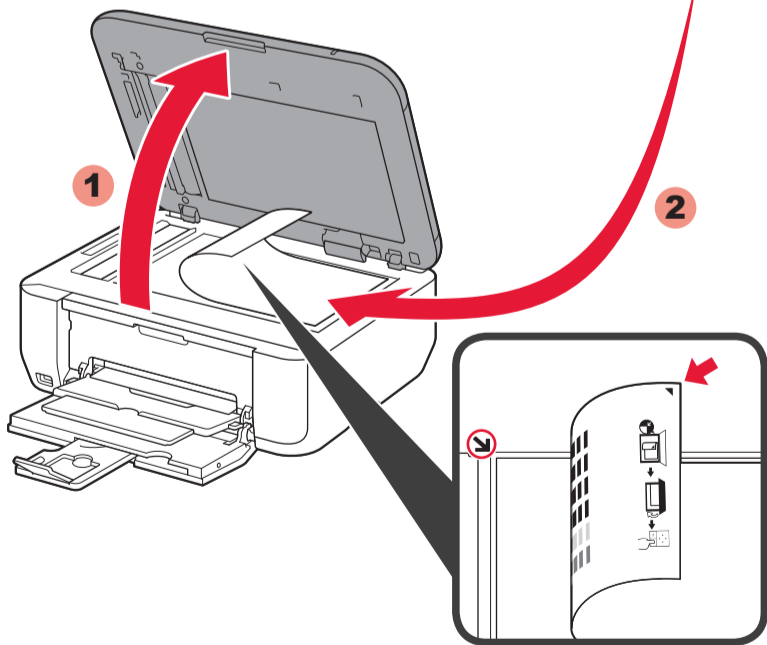
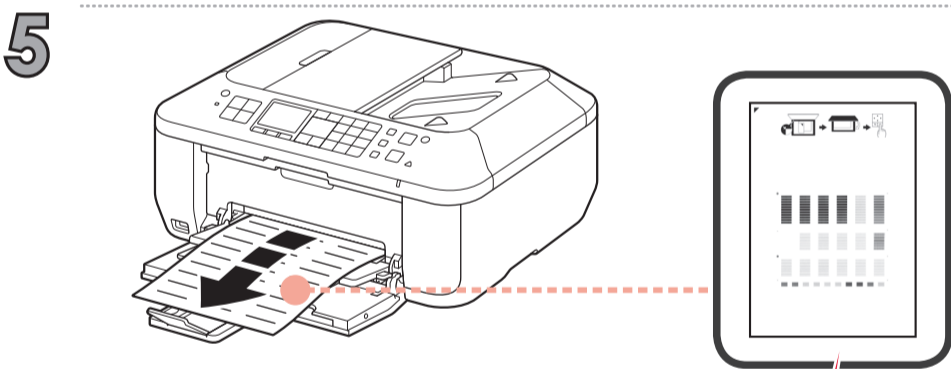
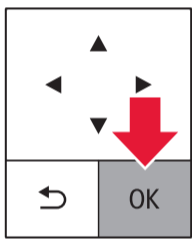
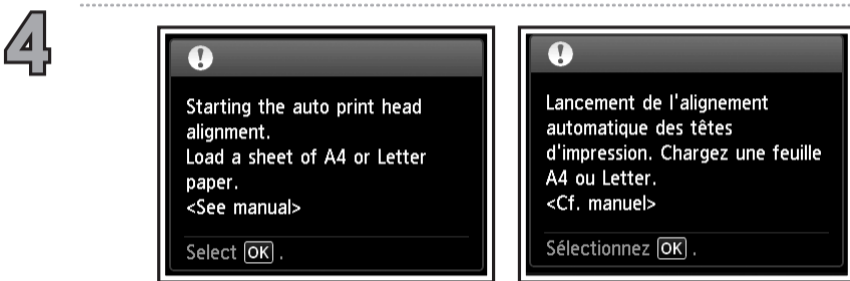
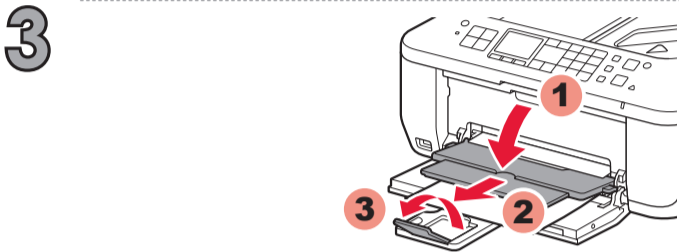
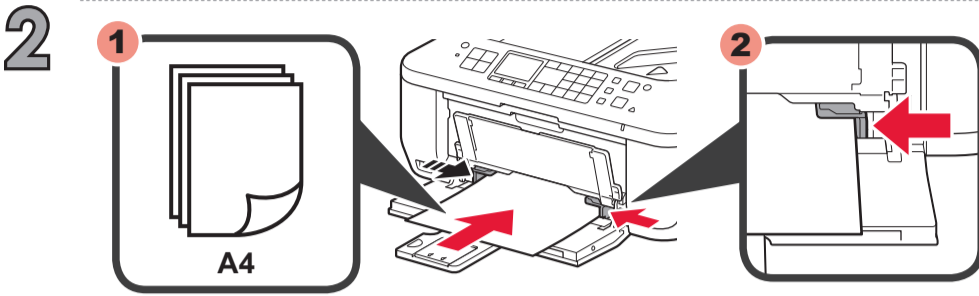
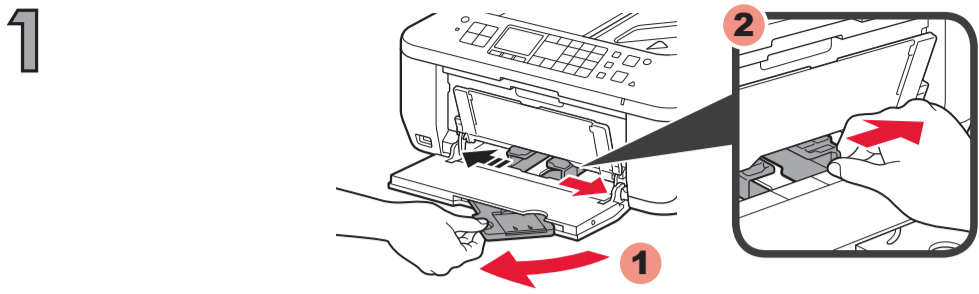

7

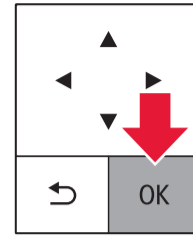
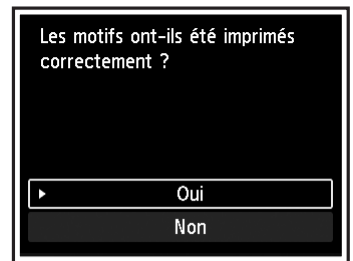
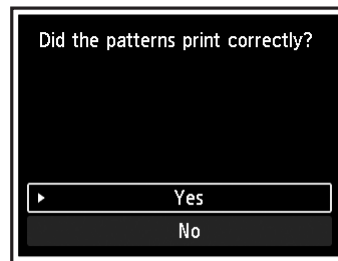

8

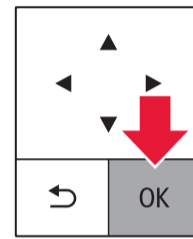
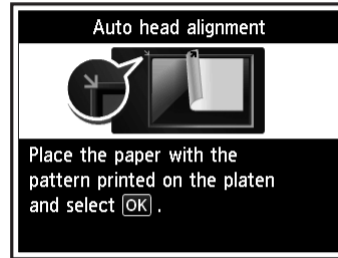

9

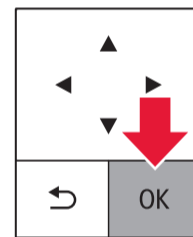
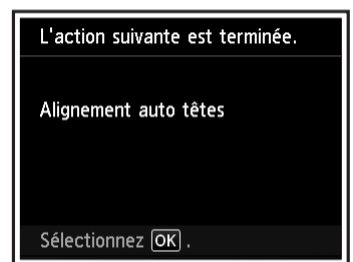

6

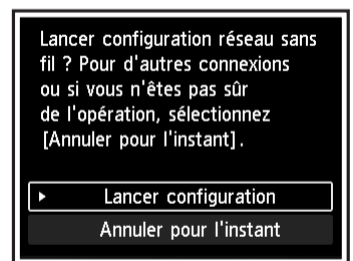
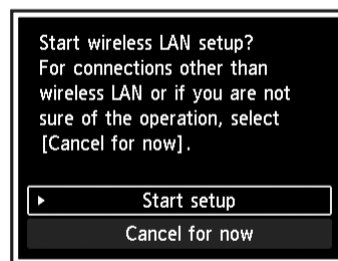

To connect to wireless LAN, select **Start setup** on the screen, then follow the on-screen instruction.

If you do not want to connect the machine to wireless LAN, select **Cancel for now**, then proceed to **7**.

* You can select USB connection or wired LAN connection by following the instruction shown on the computer screen in **7**.

Pour vous connecter au réseau local sans fil, sélectionnez **Lancer configuration** sur l'écran, puis suivez les instructions à l'écran.

Si vous ne souhaitez pas connecter la machine au réseau local sans fil, sélectionnez **Annuler pour l'instant**, puis passez à l'étape **7**.

* Vous pouvez utiliser une connexion USB ou une connexion au réseau local filaire en suivant les instructions affichées sur l'écran de l'ordinateur dans **7**.

Wählen Sie für eine WLAN-Verbindung die Option **Einrichtung starten (Start setup)** auf dem Bildschirm aus, und folgen Sie der Anleitung auf dem Bildschirm.

Wenn Sie keine WLAN-Verbindung herstellen möchten, wählen Sie **Vorerst abbrechen (Cancel for now)** aus, und fahren Sie mit **7** fort.

* Sie können eine USB-Verbindung oder eine drahtgebundene LAN-Verbindung wählen, indem Sie der Anleitung auf dem Computerbildschirm unter **7** folgen.

Selecteer **Instelling starten (Start setup)** op het scherm en volg de instructies op het scherm om een draadloze LAN-verbinding te maken.

Als u geen draadloze LAN-verbinding wilt maken, selecteert u **Nu annuleren (Cancel for now)** en gaat u verder met **7**.

* U kunt USB of bedrade LAN-verbinding selecteren door de instructies op het computerscherm bij **7** te volgen.

Per connettersi alla LAN wireless, selezionare **Avvia impostazione (Start setup)**, quindi seguire le istruzioni visualizzate sullo schermo.

Se non si desidera connettere la macchina alla LAN wireless, selezionare **Annulla per ora (Cancel for now)**, quindi passare a **7**.

* È possibile selezionare una connessione USB o una connessione LAN cablata seguendo le istruzioni mostrate sullo schermo del computer in **7**.

Para conectar-se com uma LAN sem fio, selecione **Iniciar configuração (Start setup)** na tela e siga as instruções exibidas.

Se você não quiser conectar a máquina à LAN sem fio, selecione **Cancelar por enquanto (Cancel for now)** e, em seguida, prossiga para o **7**.

* É possível selecionar uma conexão USB ou uma conexão de LAN com fio seguindo as instruções mostradas na tela do computador no **7**.

Para conectar una LAN inalámbrica, seleccione **Iniciar configuración (Start setup)** en la pantalla y, a continuación siga las instrucciones en pantalla.

Si no desea conectar el equipo a la LAN inalámbrica, seleccione **Cancelar por ahora (Cancel for now)** y, a continuación continúe con **7**.

* Puede seleccionar la conexión USB o la conexión LAN cableada siguiendo las instrucciones que se muestran en la pantalla del ordenador en **7**.

Για να συνδεθείτε στο ασύρματο LAN, στην οθόνη επιλέξτε **Εκκίνηση ρύθμισης (Start setup)** και, στη συνέχεια, ακολουθήστε τις οδηγίες που εμφανίζονται.

Εάν δεν θέλετε να συνδέσετε το μηχάνημα σε ασύρματο LAN, επιλέξτε **Προσωρινή ακύρωση (Cancel for now)** και, στη συνέχεια, προχωρήστε το κεφάλαιο **7**.

* Μπορείτε να επιλέξετε σύνδεση USB ή σύνδεση ενσύρματου LAN ακολουθώντας τις οδηγίες που εμφανίζονται στην οθόνη του υπολογιστή στο κεφάλαιο **7**.

7

1

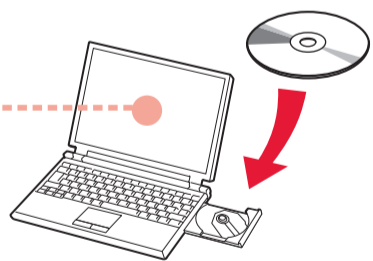

Windows



Msetup4.exe

Mac



Setup

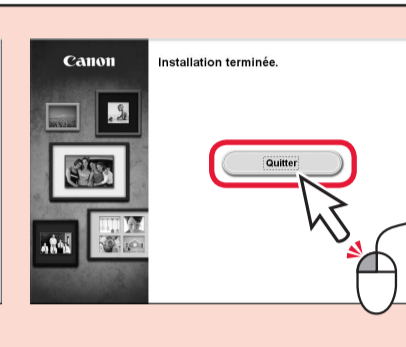
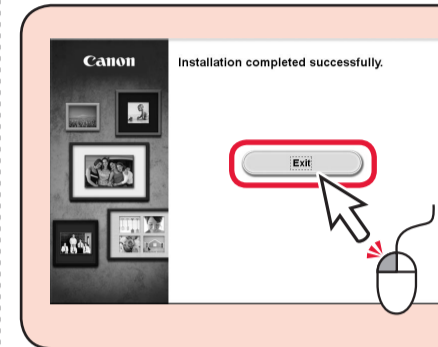
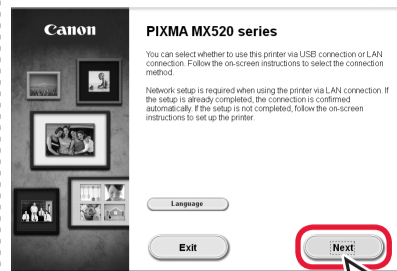

541XL
Color

540XL
Black

541
Color

540
Black

