

1 Unpack the Printer

- 1 Carefully remove all items from the box.

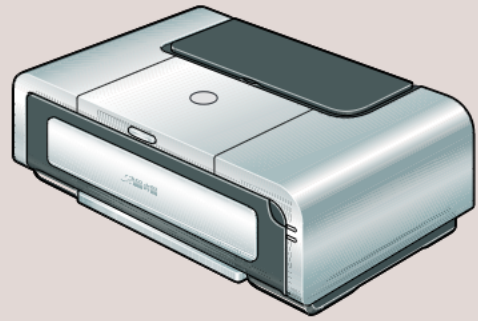

PIXMA iP5200 Photo Printer



Documentation and Software Kit



PIXMA iP5200 Print Head



Power Cord

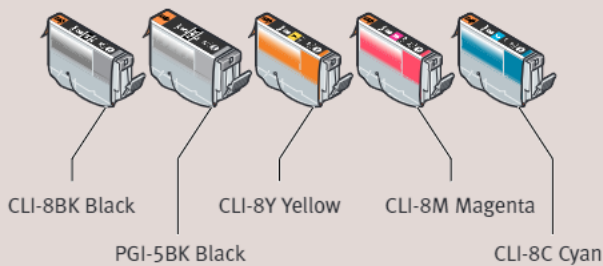

Ink Tanks

- 2 Remove the tape from the printer.

2 Prepare the Printer

- 1 Before turning on the printer, open the top cover and remove the protective material and tape from the printer as shown. The tape position is subject to change.

CAUTION: Be sure to remove the protective material before you turn on the printer.

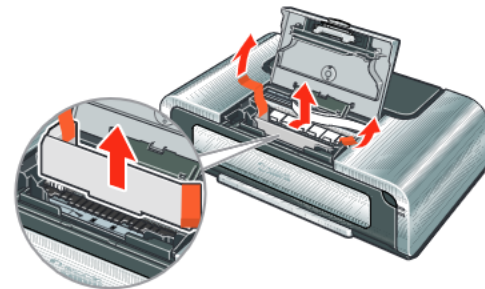

- 2 Close the top cover. Plug the power cord into the back of the printer and connect the other end to a power outlet. Press the POWER button. The printer will initialize. Wait until the POWER lamp displays a steady green light.

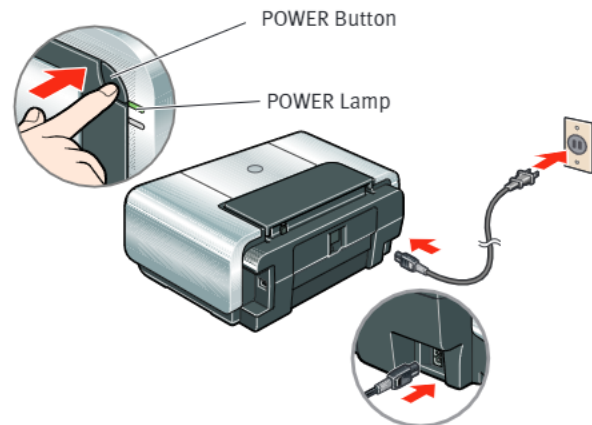

- 3 Open the front cover. Raise the top cover. Lower the inner cover.

NOTE: Push the open button above the front cover. The front cover automatically opens.

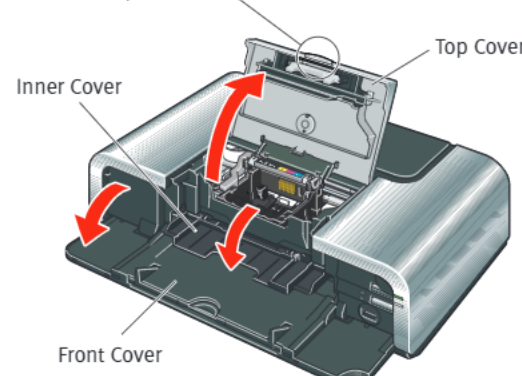

- 4 The print head holder automatically moves to the center. Write down the serial number located inside the printer. You will need this to register your products.

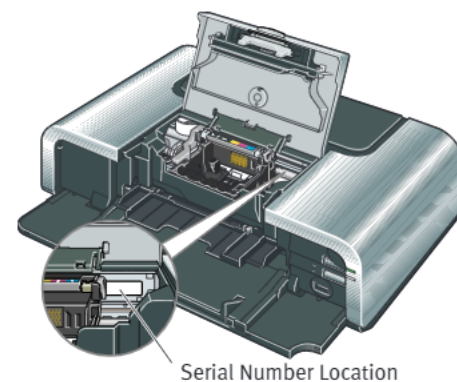

IMPORTANT: If the top cover is left open for more than 10 minutes, the print head holder moves to the right. Close and reopen the top cover to return the holder to the center.

3 Install the Print Head

- 1 Remove the print head from its package.

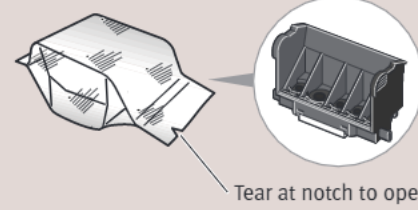

CAUTION: There might be some transparent or light blue ink on the inside of the bag the print head comes in - this has no effect on print quality. Be careful not to get ink on yourself when handling these items.

- 2 Remove the orange protective cap from the print head.

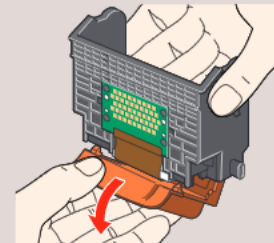

CAUTION: There might be some transparent or light blue ink on the inside of the protective cap - this has no effect on print quality. Be careful not to get ink on yourself when handling these items.

NOTE:

- Do not touch the print head nozzles and the electrical contacts.
- Do not attempt to reattach the protective cap once it has been removed.

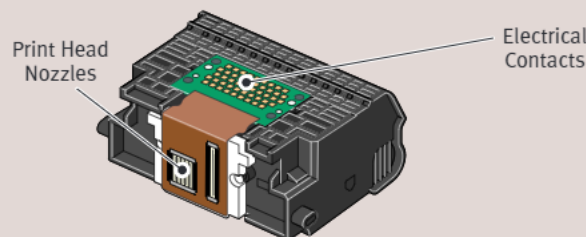

- 3 Firmly raise the print head lock lever.

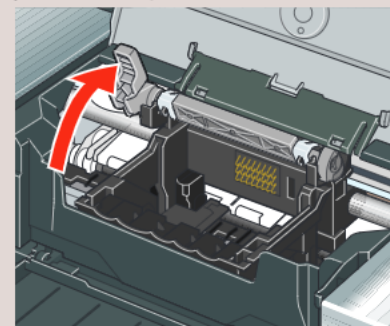

- 4 Slide the print head into the holder. The print head will rest at a slight angle.

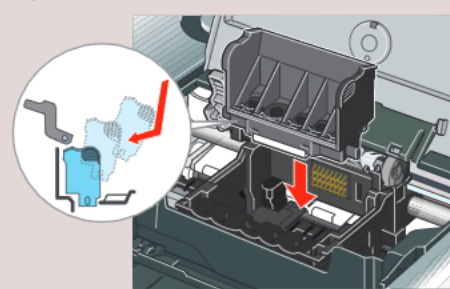

- 5 Lower the print head lock lever carefully and press it down.

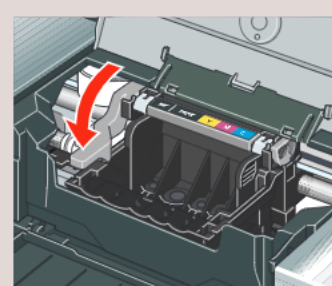

4 Install the Ink Tanks

- 1 Peel back the orange tab completely and remove the plastic wrapper from the Cyan Ink Tank (CLI-8C).

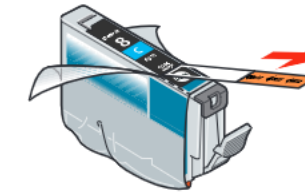

- 2 Twist off and discard the orange protective cap located on the bottom of the ink tank.

IMPORTANT: Do not touch the electrical contacts.

NOTE:

- To avoid spilling ink, never press on the sides of an ink tank.
- Do not touch the open ink port once the protective cap is removed, as this may prevent the ink from being ejected properly.

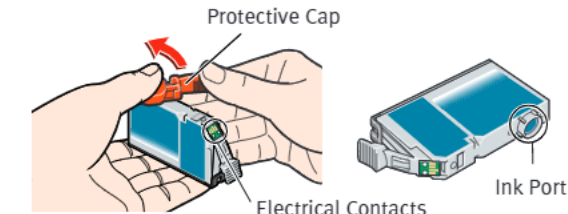

- 3 Insert the ink tank into the rightmost slot. Press the mark on the ink tank until it clicks into place and then its lamp lights red.

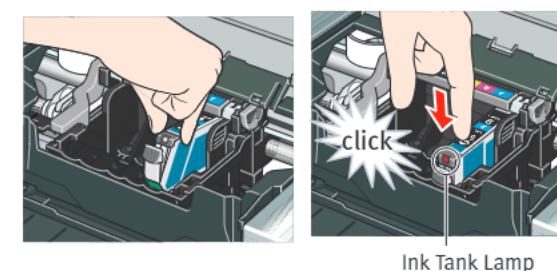

- 4 Insert the remaining four ink tanks into their assigned slots. Ensure that ink tank lamps light red.

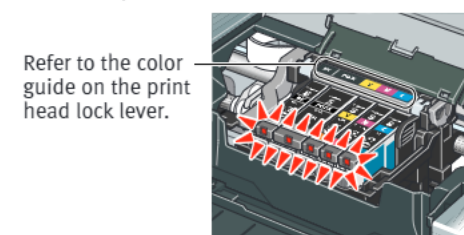

- 5 Close (a) the inner cover and then (b) the top cover. Lift open the paper support and extend the paper output tray.

IMPORTANT: Be sure to close the inner cover completely, or the paper will not feed properly.

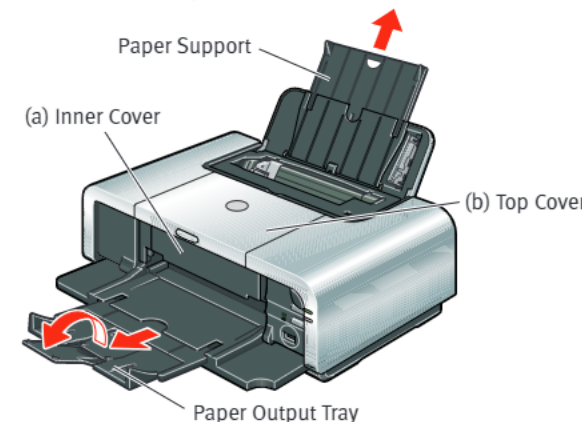

NOTE:

- The printer will perform a print head cleaning. Wait until the POWER lamp displays a steady green light before proceeding.
- If the ALARM lamp still flashes orange even after the printer has stopped making operating noises, an ink tank may not be installed properly. Open the top cover and make sure that the ink tanks are installed in the correct order directed on the label.

5 Connect the Printer and Load Paper

IMPORTANT: Be sure the printer is off before continuing, or the computer will attempt to install the printer driver before the printer is ready.

- 1 TURN THE PRINTER OFF.

- 2 Connect one end of the USB cable to the computer, the other to the appropriate USB port on the printer.

NOTE: The iP5200 Photo Printer is equipped with USB 2.0 Hi-Speed port. If your PC does not support USB 2.0 Hi-Speed, or if any non-certified USB 2.0 cable or driver is used for the connection, the printer will operate at a lower speed provided under USB 1.1.

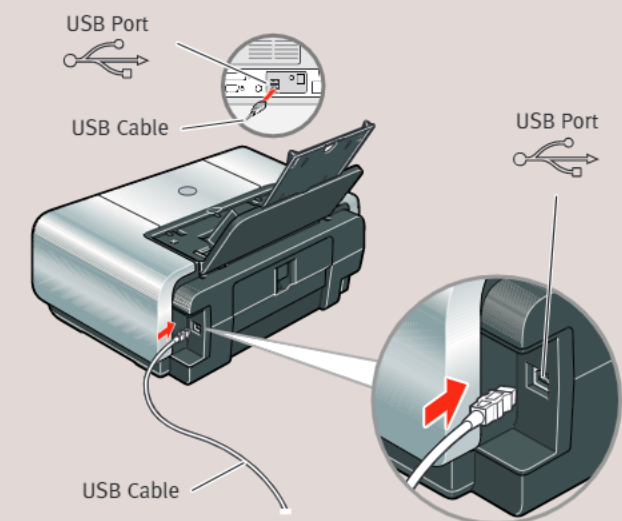

- 3 Pinch the paper guide and slide it to the left. Load a few sheets of blank paper into the auto sheet feeder, align the paper with the cover guide, then slide the paper guide toward the left edge of the paper.

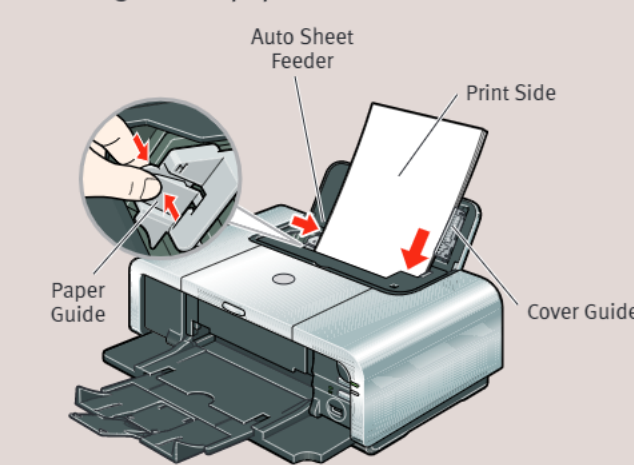

IMPORTANT: Print Head Alignment (Step 6) requires that letter size paper is loaded in the Auto Sheet Feeder (top paper feeder).

Continue with Step 6 on side two.



6 Windows® Printer Driver Installation and Print Head Alignment

6 Macintosh® Printer Driver Installation and Print Head Alignment

7 Cassette Loading

Windows

NOTE: The screens below refer to Windows XP Service Pack 2 installation. Screens may differ depending on the operating system you are using.

1 Be sure to **TURN THE PRINTER OFF** before continuing.

2 Turn on the computer and start Windows.

NOTE:

- For Windows XP or Windows 2000, log on to Windows as a member of the Administrators group before continuing.
- Before installing the driver, disable all anti-virus programs and automatically loading programs.

IMPORTANT: If you see the Found New Hardware Wizard, click **Cancel**. Next, remove the USB cable connected to your computer. Then proceed from step 3 to install the printer driver.



3 Insert the *Setup Software & User's Guide CD-ROM*. The setup program should run automatically.

NOTE: If the setup program does not run, click **Start**, then **Run**, then type **D:\Msetup4.exe**, where **D** is your CD-ROM drive.

4 When the main menu appears, click **Easy Install**.

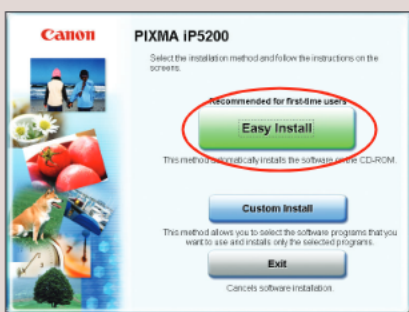

NOTE:

- Select **Easy Install** in order to install the application software, on-screen manuals and printer driver. Select **Custom Install** in order to choose the options you would like to install.
- To install PhotoRecord, click **Custom Install** and follow the instruction on the screen.

5 When the list of applications to install appears, verify the contents, click **Install**, then follow the instructions on the screen. Move the cursor over items to display explanations of each application below.

6 Read the **License Agreement** and click **Yes**. If a message asking for your confirmation to restart your computer appears, click **OK**. The system is restarted automatically.

7 When the **Printer Connection** screen appears, ensure that the printer is connected to the computer with the USB cable, then **TURN THE PRINTER ON**. The software will begin identifying the printer port being used.



IMPORTANT: If your computer cannot detect a printer port, click **Help** and refer to the online instructions.

If a message asking for your confirmation to restart your computer appears, click **OK**. The system is restarted automatically.

8 When the **Print Head Alignment** screen appears, ensure that letter size paper is loaded in the auto sheet feeder (top paper feeder). Click **Execute**, read the message and click **Print Head Alignment**.

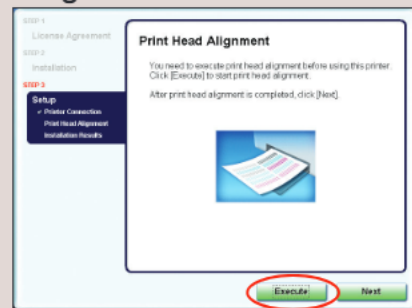

NOTE:

- Print head alignment will take several minutes to complete. Do not start another operation here.
- The pattern is printed in black and blue.

9 After print head alignment is completed, click **Next**.

10 When the **Installation Results** screen appears, click **Next**.

11 Follow the on-screen instructions to register your product.

12 When the **Installation completed successfully** screen appears, click **Exit**. If **Restart** is displayed, ensure the **Restart the system now (recommended)** check box is selected, then click **Restart**.

Macintosh

NOTE:

- Use Mac® OS X v.10.2.1 to 10.3.x.
- The screens below refer to Mac OS X v.10.3.x installation. Screens may differ depending on the operating system you are using.
- Before installing the driver, disable all anti-virus programs and automatically loading programs.

1 Turn on your Mac and your printer and insert the *Setup Software & User's Guide CD-ROM*. If the CD-ROM folder does not open automatically, double-click the  on the desktop.

NOTE: Log on as an Administrator before continuing.

2 Double-click the **Setup** icon.

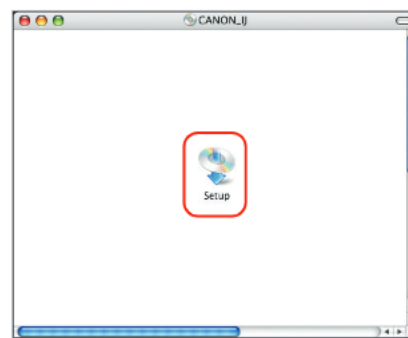

NOTE: When the **Authenticate** screen appears, enter your administrator name and password. If you do not know your administrator name or password, click **?** on the lower-left corner of the screen, then follow the on-screen instructions.

3 When the main menu appears, click **Easy Install** and then **Install**, then follow the on-screen instructions.



NOTE: Select **Easy Install** in order to install the application software, on-screen manuals and printer driver. Select **Custom Install** in order to choose the options you would like to install.

4 Read the **License Agreement** and click **Yes**.

5 Follow the on-screen instructions to register your product.

6 When the **Print Head Alignment Recommended** screen appears, click **Next**.

7 When the **Installation completed successfully** screen appears, click **Restart**.



The system is restarted automatically.

8 Start the print head alignment procedure.

a. After restarting the computer, select **Applications** from the **Go** menu. Double-click the **Utilities** folder, then the **Printer Setup Utility (Print Center)** when using Mac OS X v.10.2.x icon.

b. When the **Printer List** screen appears, select **iP5200**, then click **Utility (Configure)** when using Mac OS X v.10.2.x icon.

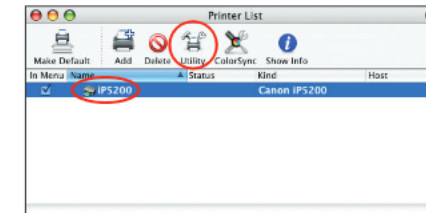

If the printer is not displayed on the **Printer List**, click **Add** to add the printer.

For details, follow the instructions in **Mac Help**.

c. Select **iP5200** and click **Maintenance**.

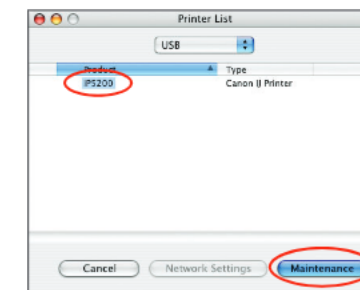

d. Ensure that letter size paper is loaded in the auto sheet feeder (top paper feeder).

e. Click the down-arrow to select **Test Print**. Click the **Print Head Alignment** icon and follow the on-screen instructions.

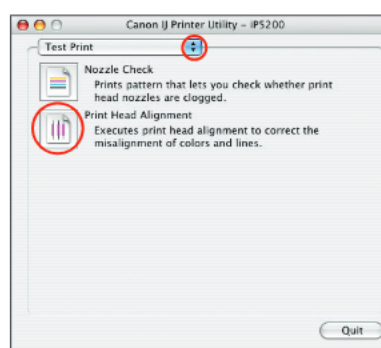

NOTE:

- Print head alignment will take several minutes to complete. Do not start another operation here.
- The pattern is printed in black and blue.

9 Click **Quit** to exit the Canon IJ Printer Utility. Print head alignment is now complete.

You can load paper in both the auto sheet feeder and cassette.

1 Pull out the cassette from the bottom of the printer.

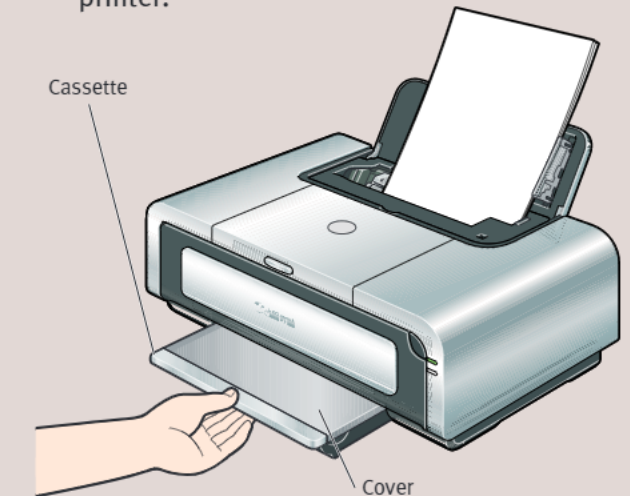

2 Remove the cover of the cassette.

3 For A5 or larger sized paper, pull the tab towards you to unlock and extend the cassette.

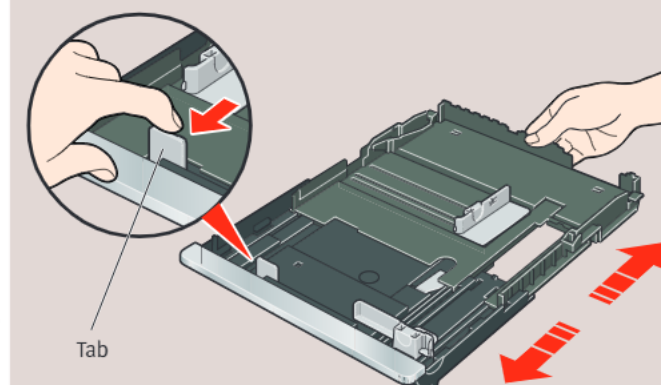

A5 or larger
(nonstandard-size paper: 203 mm / 8 inches or more in length)

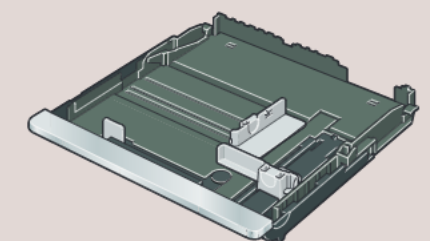

5" x 7" or smaller
(nonstandard-size paper: less than 203 mm / 8 inches in length)

4 Load the paper into the cassette with the print side facing DOWN.

NOTE: Loading paper in the cassette provides additional paper handling flexibility. For additional information visit the electronic *User's Guide*.