



Brother Laser Printer **SERVICE MANUAL**

MODEL: MFC-P2500 / HL-P2500



Read this manual thoroughly before maintenance work.
Keep this manual in a convenient place for quick and easy reference at all times.

December, 1999
SM-PRN003

© Copyright Brother 1999

All rights reserved.

No part of this publication may be reproduced in any form or by any means without permission in writing from the publisher.

Specifications are subject to change without notice.

Trademarks:

The brother logo is a registered trademark of Brother Industries, Ltd.

Apple, the Apple Logo, and Macintosh are trademarks, registered in the United States and other countries, and True Type is a trademark of Apple computer, Inc.

Hewlett Packard is a registered trademark and HP Laser Jet is a trademark of Hewlett Packard Company.

IBM and IBM PC are registered trademarks of International Business Machines Corporation.

Microsoft and MS-DOS are registered trademarks of Microsoft Corporation.

Windows is a registered trademark of Microsoft Corporation in the U.S. and other countries.

PREFACE

This service manual contains basic information required for after-sales service of the laser printer (hereinafter referred to as "this machine" or "the printer"). This information is vital to the service technician to maintain the high printing quality and performance of the printer.

This service manual covers the MFC-P2500 / HL-P2500 printers.

This manual consists of the following chapters:

CHAPTER 1: GENERAL

Features, specifications, etc.

CHAPTER 2: INSTALLATION AND BASIC OPERATION

Installation conditions, Installation procedures, basic operation of the printer etc.

CHAPTER 3: THEORY OF OPERATION

Basic operation of the mechanical system, the electrical system and the electrical circuits and their timing information.

CHAPTER 4: DISASSEMBLY AND RE-ASSEMBLY

Procedures for disassembling and re-assembling the mechanical system.

CHAPTER 5: PERIODIC MAINTENANCE

Periodical replacements parts, consumable parts, etc.

CHAPTER 6: INSPECTION MODE

Test print mode & maintenance mode.

CHAPTER 7: TROUBLESHOOTING

Reference values and adjustments, troubleshooting image defects, troubleshooting malfunctions, etc.

APPENDICES : Serial No. descriptions, Diameter / circumference of rollers, Drum life & page counter, Self-diagnostics tool, Connection diagrams, PCB circuit diagrams, etc.

Information in this manual is subject to change due to improvement or redesign of the product. All relevant information in such cases will be supplied in service information bulletins (Technical Information).

A thorough understanding of this printer, based on information in this service manual and service information bulletins, is required for maintaining its print quality performance and for improving the practical ability to find the cause of problems.

TABLE OF CONTENTS

REGULATION	vii
SAFETY INFORMATION	ix
CHAPTER 1 GENERAL.....	1-1
1. FEATURES.....	1-1
2. OVERVIEW	1-4
3. SPECIFICATIONS	1-5
3.1 Printing.....	1-5
3.2 Scanning.....	1-5
3.3 Copying.....	1-6
3.4 Functions	1-6
3.5 Electrical and Mechanical	1-7
3.6 Paper	1-8
3.6.1 Feedable paper.....	1-8
3.6.2 Paper cassette capacity.....	1-9
3.6.3 Print delivery	1-9
3.7 Printing Area	1-10
3.7.1 Effective printing area	1-10
3.7.2 Print guaranteed area	1-10
3.8 Document.....	1-12
3.8.1 Feedable document	1-12
3.8.2 Document delivery	1-12
3.8.3 Scannable area.....	1-13
CHAPTER 2 INSTALLATION AND BASIC OPERATION.....	2-1
1. CONDITIONS REQUIRED FOR INSTALLATION	2-1
1.1 Power Supply.....	2-1
1.2 Environment.....	2-1
1.3 System Requirements for Brother Printing Solution for Windows®	2-1
2. UNPACKING	2-2
3. INSTALL THE PRINTER.....	2-3
3.1 For Windows® Users	2-3
3.2 Use the USB Interface (For Windows® 98 only).....	2-5
3.2.1 Connect the USB interface cable.....	2-5
3.2.2 Install the USB driver	2-5
3.3 For Macintosh (iMac and Power Macintosh G3 with USB) Users Only	2-8
4. PAPER HANDLING	2-9
4.1 Load Paper into the Paper Cassette.....	2-9
4.2 Load Paper Manually	2-9
4.3 Two Side Printing (Manual Duplexing).....	2-10

4.3.1	Print on both sides of paper from the paper cassette	2-11
4.3.2	Print on both sides of paper from the manual feed slot	2-11
5.	CONTROL PANEL OPERATION	2-12
5.1	LED Indications	2-12
5.2	Button Functions	2-13
5.3	LCD Indications	2-14
5.3.1	Normal mode	2-14
5.3.2	Test print mode	2-16
6.	COPYING OPERATIONS	2-17
6.1	How to Copy	2-17
6.2	Settings for Copy	2-18
6.2.1	Enlarge/Reduce	2-18
6.2.2	Document type	2-18
6.2.3	Density	2-19
6.2.4	Options	2-19
6.2.5	Paper size	2-19
6.2.6	Sort	2-19
7.	SCANNING OPERATION	2-20
7.1	Scanning from the PaperPort® for Brother Software (for USA/Canada)	2-20
7.2	Scanning from the Unimessage™ Pro Viewer Software (for Other Countries than USA/Canada)	2-20
7.3	Scanning from TWAIN Compliant Applications	2-21
7.4	Scanning from Control Panel Operation	2-21
7.4.1	Pressing the Scan to File button for MFC-P2500	2-21
7.4.2	Pressing the Scan to Email button for MFC-P2500	2-22
7.4.2	Pressing the Scan to File button for HL-P2500	2-22
7.4.4	Pressing the Scan to Email button for HL-P2500	2-22
CHAPTER 3 THEORY OF OPERATION		3-1
1.	ELECTRONICS	3-1
1.1	General Block Diagram	3-1
1.2	Main PCB Block Diagram	3-2
1.3	Main PCB	3-3
1.3.1	ASIC	3-3
1.3.2	ROM	3-4
1.3.3	DRAM	3-5
1.3.4	EEPROM	3-5
1.3.5	Reset circuit	3-6
1.3.6	Engine I/O	3-6
1.3.7	Scanner panel I/F	3-7
1.3.8	Scanner motor drive circuit	3-7
1.3.9	CIS drive circuit	3-8
1.4	Engine PCB	3-9
1.5	Control Panel PCB	3-9
1.6	Power Supply	3-10
1.6.1	Low-voltage Power Supply	3-10
1.6.2	High-voltage Power Supply	3-11

2. MECHANICS	3-12
2.1 General Overview of Mechanism.....	3-12
2.2 Printer Mechanism.....	3-14
2.2.1 Paper transfer	3-14
2.2.2 Sensors.....	3-15
2.2.3 Drum unit	3-16
2.2.4 Toner Cartridge.....	3-16
2.2.5 Print Process.....	3-17
2.3 Scanner Mechanism.....	3-20
2.3.1 Document transfer (feed and eject)	3-20
2.3.2 Scanner.....	3-20
CHAPTER 4 DISASSEMBLY AND RE-ASSEMBLY	4-1
1. SAFETY PRECAUTIONS	4-1
2. DISASSEMBLY FLOW	4-2
3. DISASSEMBLY PROCEDURE	4-3
3.1 AC Cord.....	4-3
3.2 Drum Unit.....	4-3
3.3 Paper Cassette	4-4
3.4 Control Panel ASSY.....	4-10
3.5 Document Scanner Frame ASSY	4-14
3.6 Front Cover	4-20
3.7 Top Cover	4-21
3.8 Main Cover.....	4-23
3.9 Laser Unit.....	4-25
3.10 Drive Unit.....	4-26
3.11 Fixing Unit.....	4-27
3.12 Base Plate.....	4-37
3.13 Main PCB ASSY	4-39
3.14 Lower Tray Relay PCB ASSY.....	4-40
3.15 Low-voltage Power Supply PCB ASSY	4-40
3.16 Engine PCB ASSY / High-voltage Power Supply PCB ASSY	4-42
3.17 Solenoid ASSY	4-44
3.18 Fan Motor ASSY	4-47
3.19 Toner Empty PCB ASSY (Light Emission).....	4-48
3.20 Toner Empty PCB ASSY (Light Reception).....	4-48
3.21 Paper Pick-up Roller ASSY	4-49
3.22 Paper Feed Roller ASSY	4-50
4. GREASE APPLICATION	4-51
5. PACKING	4-55

CHAPTER 5 PERIODIC MAINTENANCE	5-1
1. CONSUMABLE PARTS	5-1
1.1 Drum Unit.....	5-1
1.2 Toner Cartridge.....	5-2
2. PERIODICAL REPLACEMENT PARTS.....	5-4
3. PERIODICAL CLEANING	5-5
3.1 Clean the Printer Exterior.....	5-5
3.2 Clean the Drum Unit	5-5
3.3 Clean the Scanner Window	5-6
3.4 Clean the Electrical Terminals	5-6
3.5 Clean the Scanning Unit.....	5-7
4. MTBF / MTRR	5-8
 CHAPTER 6 MAINTENANCE MODE.....	 6-1
1. TEST PRINT MODE	6-1
2. MAINTENANCE MODE	6-2
2.1 EEPROM Parameter Initialization.....	6-3
2.2 Printout of Scanning Compensation Data.....	6-3
2.3 ADF Performance Test.....	6-5
2.4 Test Pattern 1	6-5
2.5 Operational Check of LCD.....	6-6
2.6 Operational Check of Control Panel PCB.....	6-6
2.7 Sensor Operational Check.....	6-7
2.8 CIS Scanner Area Setting.....	6-8
2.9 EEPROM Customizing.....	6-8
2.10 Printer Error Code Indication	6-9
 CHAPTER 7 TROUBLESHOOTING.....	 7-1
1. INTRODUCTION	7-1
1.1 Initial Check	7-1
1.2 Warnings during Maintenance	7-2
1.3 Identify the Problem.....	7-3
2. ERROR MESSAGE	7-4
2.1 Error Messages on the Control Panel.....	7-4
2.1.1 Operator call error messages	7-4
2.1.2 Service call error messages.....	7-6
2.2 Error Messages in the Status Monitor	7-8
2.3 Error Message Printouts.....	7-9
3. PAPER PROBLEM	7-10
3.1 Paper Load Problems	7-10
3.2 Paper Jam.....	7-11
5.2.1 Clear the jammed paper.....	7-11
5.2.2 Cause & countermeasure	7-12

3.3	Paper Feeding Problem.....	7-13
4.	DOCUMENT PROBLEMS	7-15
5.	SOFTWARE SETTING PROBLEMS	7-17
6.	MALFUNCTIONS.....	7-20
7.	IMAGE DEFECTS.....	7-25
7.1	Image Defect Examples.....	7-25
7.2	Troubleshooting Image Defect.....	7-26
7.3	Location of Grounding Contacts	7-47
7.3.1	Drum unit	7-47
7.3.2	Printer body & paper cassette.....	7-47
8.	INCORRECT PRINTOUT	7-48

APPENDICES

1.	SERIAL NO. DESCRIPTIONS	A-1
2.	DIAMETER / CIRCUMFERENCE OF ROLLERS.....	A-3
3.	PRINT SPEEDS WITH VARIOUS SETTINGS	A-4
4.	HOW TO KNOW DRUM UNIT LIFE & PAGE COUNTER	A-5
5.	NVRAM DEFAULT VALUE	A-8
6.	PAPER CASSETTE INFORMATION (FOR EUROPE ONLY).....	A-9
7.	CONNECTION DIAGRAM	A-10
8.	MAIN PCB CIRCUIT DIAGRAM (1/3)	A-11
9.	MAIN PCB CIRCUIT DIAGRAM (2/3)	A-12
10.	MAIN PCB CIRCUIT DIAGRAM (3/3)	A-13
11.	ENGINE PCB CIRCUIT DIAGRAM.....	A-14
12.	CONTROL PANEL PCB CIRCUIT DIAGRAM.....	A-15
13.	LOW-VOLTAGE POWER SUPPLY PCB CIRCUIT DIAGRAM, (110 - 120V)	A-16
14.	LOW-VOLTAGE POWER SUPPLY PCB CIRCUIT DIAGRAM, (220 - 240V)	A-17
15.	HIGH-VOLTAGE POWER SUPPLY PCB CIRCUIT DIAGRAM	A-18

INDEX

REGULATIONS

LASER SAFETY (110 - 120V MODEL ONLY)

This printer is certified as a Class I laser product under the US Department of Health and Human Services (DHHS) Radiation Performance Standard according to the Radiation Control for Health and Safety Act of 1968. This means that the printer does not produce hazardous laser radiation.

Since radiation emitted inside the printer is completely confined within the protective housing and external covers, the laser beam cannot escape from the machine during any phase of user operation.

FDA REGULATIONS (110 - 120V MODEL ONLY)

The US Food and Drug Administration (FDA) has implemented regulations for laser products manufactured on and after August 2, 1976. Compliance is mandatory for products marketed in the United States. One of the following labels on the back of the printer indicates compliance with the FDA regulations and must be attached to laser products marketed in the United States.

The label for Japanese manufactured products

MANUFACTURED: BROTHER INDUSTRIES, LTD. 15-1, Naeshiro-cho, Mizuho-ku, Nagoya 467-8561, Japan. This product complies with FDA radiation performance standards, 21 CFR Subchapter J.	K
---	---

The label for Chinese manufactured products

MANUFACTURED: BROTHER Corporation (Asia) Ltd. Shenzhen Buji Nan Ling Factory Gold Garden Ind., Nan Ling Village, Buji, Rong Gang, Shenzhen, CHINA This product complies with FDA radiation performance standards, 21 CFR Subchapter J.	C
--	---

Caution

Use of controls, adjustments or performance of procedures other than those specified in this manual may result in hazardous radiation exposure.

IEC 825 (220-240V MODEL ONLY)

This printer is a Class I laser product as defined in IEC 825 specifications. The label shown below is attached in countries where required.

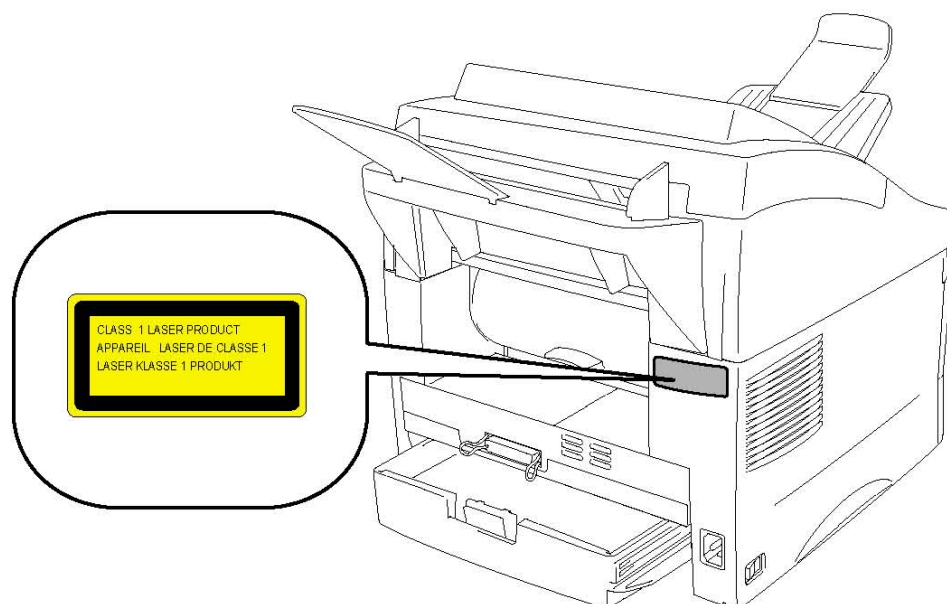

This printer has a laser diode which emits invisible laser radiation in the Laser Unit. The Laser Unit should not be opened without disconnecting the two connectors connected with the AC power supply and laser unit. Since the variable resistor in the laser unit is adjusted in accordance with the standards, never touch it.

Caution

Use of controls, adjustments or performance of procedures other than those specified in this manual may result in hazardous radiation exposure.

**For Finland and Sweden
LUOKAN 1 LASERLAITE
KLASS 1 LASER APPARAT**

Varoitus! Laitteen käyttäminen muulla kuin tässä käyttöohjeessa mainitulla tavalla saattaa altistaa käyttäjän turvallisuusluokan 1 ylittävälle näkymättömälle lasersäteilylle.

Varning – Om apparaten används på annat sätt än i denna Bruksanvisning specificerats, kan användaren utsättas för osynlig laserstrålning, som överskrider gränsen för laserklass 1.

SAFETY INFORMATION

CAUTION FOR LASER PRODUCT (WARNHINWEIS FÜR LASER DRUCKER)

CAUTION: When the machine, during servicing, is operated with the cover open, the regulations of VBG 93 and the performance instructions for VBG 93 are valid.

CAUTION: In case of any trouble with the laser unit, replace the laser unit itself. To prevent direct exposure to the laser beam, do not try to open the enclosure of the laser unit.

ACHTUNG: Im Falle von Störungen der Lasereinheit muß diese ersetzt werden. Das Gehäuse der Lasereinheit darf nicht geöffnet werden, da sonst Laserstrahlen austreten können.

<Location of the laser beam window>

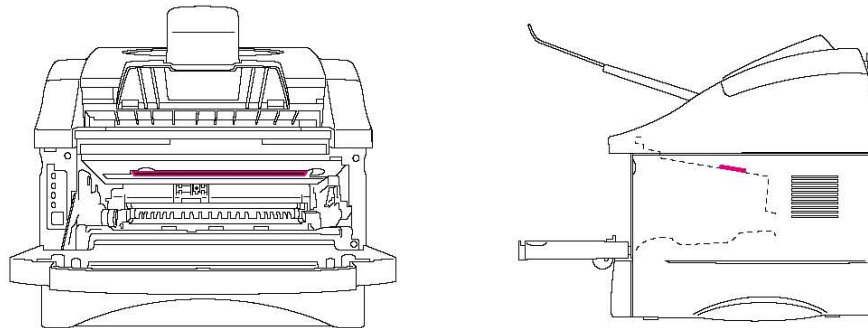

ADDITIONAL INFORMATION

When servicing or adjusting the optical system of the printer, be careful not to place a screwdriver or other reflective object in the path of the laser beam. Be sure to take off any personal accessories such as watches and rings before working on the printer. A reflected beam, though invisible, can permanently damage the eyes.

Since the beam is invisible, the following caution label is attached on the laser unit.

CAUTION	INVISIBLE LASER RADIATION WHEN OPEN AND INTERLOCK DEFEATED. AVOID DIRECT EXPOSURE TO BEAM. CLASS 3B LASER PRODUCT.
ADVARSEL	USYNTLIG LASERSTRÅLING NÅR KABINETLÅGET ER ÅBENT. UNNGÅ DIREKTE UDSÆTTELSE FOR STRÅLING. KLASSE 3B LASER.
WARNING	OSYNTLIG LASERSTRÅLING NÅR DENNA DEL ÅR ÖPPNAD OCH SPÄRRAR ÄR URKOPPLADE. STRÅLEN ÄR FARLIG. KLASSE 3B LASER APPARAT.
VARO!	AVATTAESSÄ JA SUO JÄLKITUS OHITETTAESSÄ OLET ALTTIINA NÄKYMÄTTÖMÄLLE LASERSÄTEILYLLE. ÄLÄ KATSO SÄTEESEEN. LUOKAN 3B LASERILÄITE.
ADVARSEL	USYNTLIG LASERSTRÅLING UNGÅ DIREKTE KONTAKT MED LASERENHETEN NÅR TOPPEKSELET ER ÅBENT. KLASSE 3B LASERPRODUKT.
ATTENTION	RADIATIONS LASER INVISIBLES QUAND OUVERT ET VERROUILLAGE ENLEVÉ. EVITER EXPOSITIONS DIRECTES AUFADCEAU. PRODUIT LASER CLASSE 3B.
VORSICHT	UNSICHTBARE LASERSTRÄHLUNG WENN ABDECKUNG GEÖFFNET UND SICHERHEITSVERRIEGELUNG ÜBERBRÜCKT. NICHT DEM STRAHL AUSSETZEN. SICHERHEITSKLASSE 3B.
ATENCIÓN	RADIACIÓN LASER INVISIBLE CUANDO SE ABRE LA TAPA Y EL INTERRUPTOR INTERNO ESTÁ ATASCADO. EVITE LA EXPOSICIÓN DIRECTA DE LOS OJOS. PRODUCTO LASER CLASE 3B.



DEFINITIONS OF WARNINGS, CAUTIONS AND NOTES

The following conventions are used in this service manual:

 **WARNING**

Indicates warnings that must be observed to prevent possible personal injury.

 **CAUTION:**

Indicates cautions that must be observed to carry out servicing of the printer properly or to prevent damage to the printer.

NOTE:

Indicates notes and useful tips to remember when servicing the printer.

**Listed below are the various kinds of "WARNING" messages included in this manual.

 **WARNING**

Always turn off the power switch and unplug the power cord from the power outlet before accessing any parts inside the printer.

 **WARNING**

Some parts inside the printer are extremely hot immediately after the printer is used. When opening the front cover or rear cover to access any parts inside the printer, never touch the red colored parts shown in the following figures.

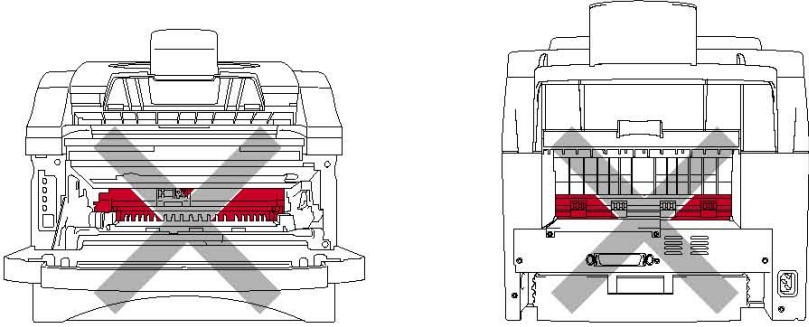

 **WARNING**

If you analyze malfunctions with the power plug inserted into the power outlet, special caution should be exercised even if the power switch is OFF because it is a single pole switch.

CHAPTER 1 GENERAL

1. FEATURES

This printer has the following features;

Three Functions in One Printer

This printer provides two additional functions, copying and scanning besides the printing function. You no longer need a lot of peripherals and can save space in your office. This is helpful especially for SOHO users.

High Resolution and Fast Print Speed

True 600 x 600 dots per inch (dpi) with microfine toner and up to 12 pages per minute (ppm) print speed (A4 or Letter paper).

Versatile Paper Handling

The printer loads paper automatically from the paper cassette. The paper cassette can hold A4, letter, B5, Executive, A5 and A6 sizes of paper. The manual feed slot allows manual paper loading sheet by sheet so you can use a variety of types and sizes of print media.

Enhanced Printing Performance and User-Friendly Operation for Windows®

The dedicated printer driver for Microsoft® Windows® 95/98, Windows® 3.1 and Windows® NT 4.0 are available on the CD-ROM supplied with your printer. You can easily install them into your Windows® system using our installer program. The driver supports our unique compression mode to enhance printing speed in Windows® applications and allows you to choose various printer settings including toner save mode, custom paper size, sleep mode, gray scale adjustment, resolution, water mark and many layout functions. You can easily setup these print options through the Printer Setup Menu.

Easy Panel Operation

The functions for the printer, scanner, copier are easy to operate. All operations and settings can be controlled from the control panel. Also, the current status of your printer is shown on the control panel LCD.

Document Management Application 'PaperPort® for Brother Software' (for US/Canada)

PaperPort® for Brother Software is a document management application which contains a viewer, editor and filing system and various links to other applications. PaperPort® for Brother Software is a sophisticated application and has widespread industry acceptance and endorsements.

Sophisticated Viewer and Document Management Software 'WordCraft Unimessage™ Pro' (for Other Countries)

WordCraft Unimessage™ Pro Viewer is a sophisticated viewer for displaying and editing graphic files. In addition to the usual image editing functions (object drawing, annotations, highlighting, etc.) you will also be able to use this software to view both color and monochrome images, create cover sheets for use with HL-P2500, display thumbnails of graphics files in any of your directories, OCR the scanned images and set up a referencing system for your files using DIR (Document Indexing Retrieval).

TWAIN Compliant Scanner Driver (for Windows® and Macintosh Users)

The scanner driver is TWAIN compliant which is a defacto standard. You can use the scanner in other TWAIN compliant applications as well as the PaperPort® application or Unimessage™ Pro viewer application.

Quick Print Setup

The Quick Print Setup is a convenient utility to allow you to make changes to frequently used printer driver settings easily without having to open the printer properties selection box every time. It is launched automatically when this printer driver is selected. You can change the settings by clicking on the icon with the right mouse button.

Printer Status Monitor for USB Interface Cable or LPT Port Users Only

The printer driver can monitor the status of your printer using bi-directional parallel communications. The use of a high quality IEEE-1284 bi-directional parallel printer cable is recommended.

The printer status monitor program can show the current status of your printer. If an error occurs, the status monitor will let you know what to correct.

Popular Printer Emulation Support

The printer supports HP LaserJet 5P (PCL5e). When you use DOS application software or Windows® version 3.0 or earlier, you can use this emulation to operate the printer.

Enhanced Memory Management

The printer provides its own data compression technology in its printer hardware and the supplied printer driver software which can automatically compress graphic data and font data efficiently into the printer's memory. You can avoid memory errors and print most full page 600 dpi graphic and text data, including large fonts, with the standard printer memory.

USB Interface (for Windows® 98, iMac and Power Macintosh G3 with USB Users only)

The printer can be connected using the Universal Serial Bus (USB) interface to a PC which has a USB interface. Drivers to allow you to use the USB port are provided on the CD-ROM supplied with the printer.

Remote Printer Console Program for DOS

The utility program, Remote Printer Console (RPC), is available on the CD-ROM supplied with your printer. When you operate your computer in a DOS (Disk Operating System) environment, this program allows you to easily change the default settings of the printer such as fonts, page setup and emulations.

This program also provides a status monitor program, which is a Terminate-and-Stay Resident (TSR) program. It can monitor the printer status while running in the background and report the current status or errors on your computer screen.

Bar Code Print

The printer can print the following 11 types of bar codes;

- Code 39
- Code 128
- Interleaved 2 of 5
- Codabar
- US-PostNet
- ISBN
- UPC-A
- UPC-E
- EAN-8
- EAN-13
- EAN-128

Environment-Friendly

<Economy Printing Mode>

This feature will cut your printing cost by saving toner. It is useful for obtaining draft copies for proof-reading. You can select the economy modes through the Windows® printer driver supplied with your printer.

<Sleep Mode (Power Save Mode)>

Sleep mode automatically reduces power consumption when the printer is not in use for a certain period of time. The printer consumes less than 10W when in sleep mode.

<Low Running Cost>

Since the toner cartridge is separate from the drum unit, you need to replace only the toner cartridge after around 3,000 pages for the standard cartridge and around 6,000 pages for the optional high-capacity cartridge, which is both cost effective and ecologically friendly.

2. OVERVIEW

<Front View>

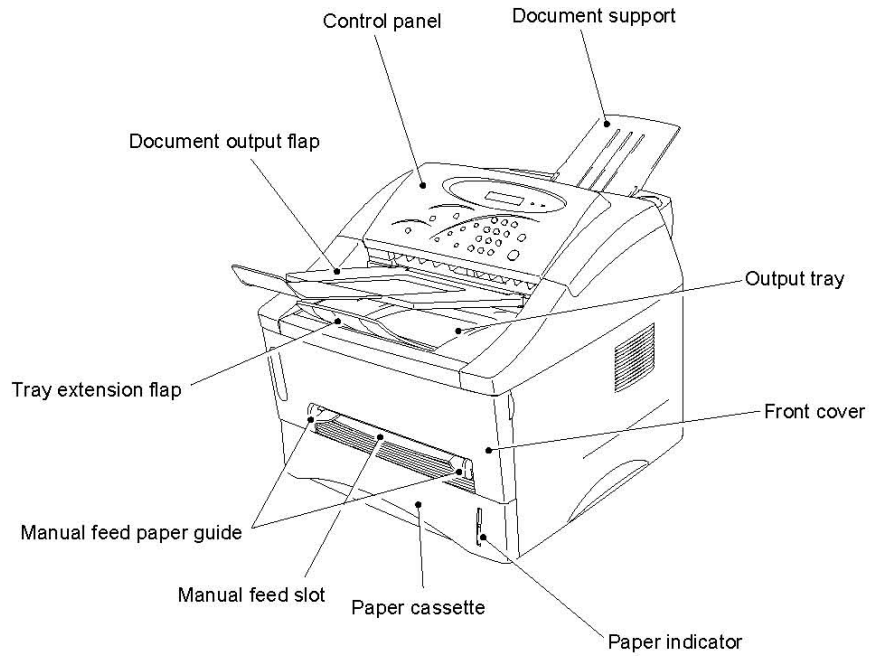

Fig. 1-1

<Rear View>

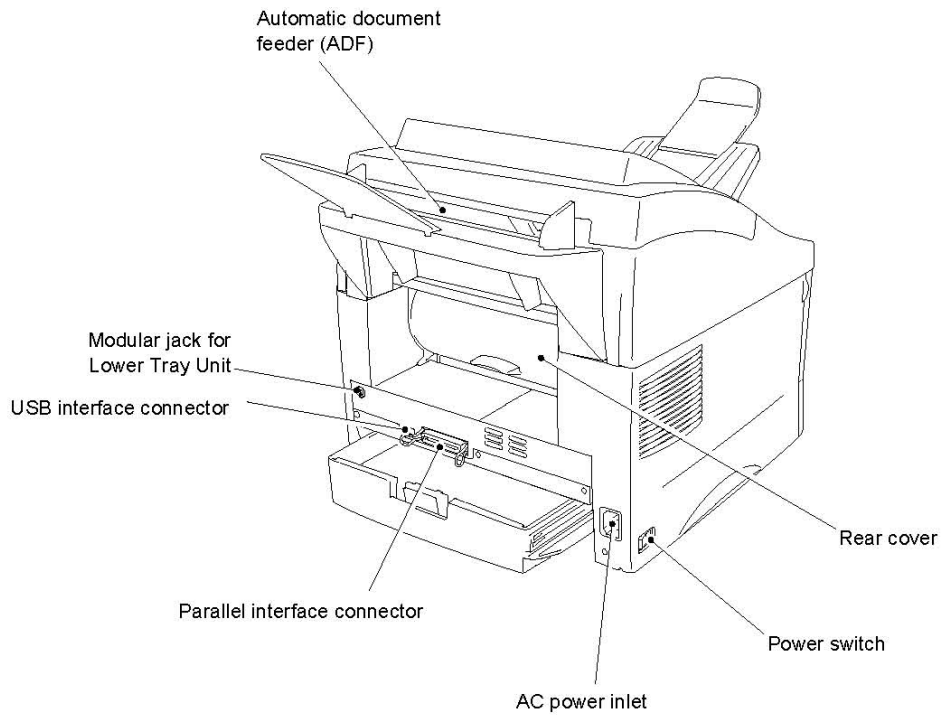

Fig. 1-2

3. SPECIFICATIONS

3.1 Printing

Print method	Electrophotography by semiconductor laser beam scanning
Laser	Wave length: 780 nm Output: 5mW max
Print resolution	600 x 600 dots/inch
Print quality	Normal printing mode Economy printing mode (up to 25% and 50% toner saving)
Print speed	Up to 12 pages/minute* (when loading A4 or Letter-size paper from the paper cassette.)
Warm-up	Max. 45 seconds at 23°C (73.4°F)
First print	15 seconds (when loading A4 or Letter-size paper from the paper cassette.)
Print media	Toner cartridge Life expectancy: 3,000 pages/cartridge (Standard cartridge) 6,000 pages/cartridge (High-capacity cartridge) (when printing A4 or Letter-size paper at 5% print coverage)
Developer	Drum unit Life expectancy: 20,000 pages/drum unit

***NOTE:**

Print speed varies depending on the paper size or media type. For details, refer to [APPENDIX 3 'PRINT SPEED IN VARIOUS SETTINGS'](#).

3.2 Scanning

Scan method	CIS (Contact Image Sensor) system
Scan resolution	600 x 600 dpi interpolated with 256 levels of gray
Scanning software	TWAIN driver (for Windows® and Macintosh users) For USA / Canada: PaperPort® for Brother Software For other countries: WordCraft Unimessage™ Pro Viewer
OCR software	Text Bridge (Xerox)

3.3 Copying

Copy resolution	600 dpi class interpolated (300 x 300 dpi optical)
Copy speed	1 copy: up to 10 ppm 2 copies or more: up to 12 ppm
Scaling	For USA / Canada: 50%, 78%, 120%, 150%, 200% Manual (50 to 200 %) For other countries: 50%, 71%, 87%, 122%, 141%, 200% Manual (50 to 200 %)
Document type setting	Text/Photo, Text, Photo

3.4 Functions

CPU	MB86832 66MHz
Emulation	Brother Printing Solution for Windows® HP LaserJet 5P (PCL level 5e)
Printer driver	<ul style="list-style-type: none"> • Windows® 3.1/3.11, Windows® 95/98, Windows NT® 4.0 driver: supporting Brother Native Compression mode • Windows® 3.1/3.11, Windows® 95/98 driver: supporting bi-directional capacity • iMac driver available for iMac System 8.1 with iMac update or higher
Printer interface	<ul style="list-style-type: none"> • Bi-directional parallel • Universal Serial Bus (USB)
Scanner interface	TWAIN 1.6 compatible
Memory	4.0 Mbytes Expandable up to 20 Mbytes by installing an optional 8MB or 16MB memory board.
Control panel	12 buttons, 1 set of 10 keys, 3 LEDs and 1 sixteen-segment LCD
Diagnostics	Self-diagnostic program

3.5 Electrical and Mechanical

Power source	U.S.A. and Canada: AC 110 to 120V, 50 Hz/60 Hz Europe and Australia: AC 220 to 240V, 50 Hz/60 Hz
Power consumption	Printing (peak)*: 940 W or less Printing (average): 340 W or less Standing by: 80 W or less Sleep*: 10 W or less
Noise	Printing: 50 dB A or less Standing by: 27 dB A or less
Temperature	Operating: 10 to 32.5°C (50 to 90.5°F) Non operating: 0 to 40°C (38 to 104°F) Storage: -20 to 40°C (-4 to 104°F)
Humidity	Operating: 20 to 80% (non condensing) Storage: 10 to 85% (non condensing)
Dimensions (W x D x H)	A4 paper cassette installed: 360 x 413 x 337 mm (14.2 x 16.3 x 13.3 inches) Legal paper cassette installed: 360 x 430 x 337 mm (14.2 x 16.9 x 13.3 inches) A4 lower paper cassette installed: 360 x 413 x 447 mm (14.2 x 16.3 x 17.6 inches) Legal lower paper cassette installed: 360 x 430 x 447 mm (14.2 x 16.9 x 17.6 inches)
Weight	Approx. 12 kg (26.5 lb.) including the drum unit.

***NOTE:**

- The peak figure of power consumption is worked out when the halogen heater lamp is turned ON.
- The peak figure of power consumption is worked out excluding inrush current value.
- The peak figure of power consumption is a reference value and should be used internally at Brother offices only.
- The power consumption figure quoted for sleep mode is when the fan has stopped.

3.6 Paper

3.6.1 Feedable paper

(1) Type & size

Feeding source	Paper type	Paper size
Paper cassette	Normal paper	A4, Letter, B5 (ISO), A5, A6, Executive, Legal*
	Transparencies	A4, Letter
Manual feed slot	Normal paper	A4, Letter, B5 (JIS/ISO), A5, A6, Executive, Legal*
	Envelopes	DL, C5, COM10, Monarch, B5 (ISO)
	Organizers	J, K, L sizes of DAY-TIMER
	Labels	A4, Letter
	Transparencies	A4, Letter
	Other sizes	70-216 x 116-356 mm (2.75-8.5 x 4.57-14 inches)
Optional lower paper cassette	Normal paper	A4, Letter, B5 (ISO), A5, Executive, Legal*

***NOTE:**

Legal-size paper can be printed with the standard paper cassette or the optional lower cassette for USA, Canada and Mexico models only.

(2) Other paper specifications

<Paper Cassette>

	Cut sheet
Basis weight	64 to 105 g/m ² (17 to 28 lb.)
Caliper	0.08 to 0.13 mm (0.003 to 0.005 in.)
Moisture content	4% to 6% by weight

<Manual Feed Slot>

	Cut sheet	Envelope
Basis weight	64 to 158 g/m ² (17 to 43 lb.)	75 to 90 g/m ² (20 to 24 lb.) single thickness
Caliper	0.08 to 0.2 mm (0.003 to 0.008 in.)	0.084 to 0.14 mm (0.003 to 0.005 in.) single thickness
Moisture content	4% to 6% by weight	4% to 6% by weight

(3) Recommended paper

- Letter: Xerox 4200 (75 g/m²) or equivalent
- A4: Xerox 80 Premier Paper (80 g/m²) or equivalent
- Label: Avery laser label or equivalent
- Transparency: 3M CG3300 or equivalent

! CAUTION:

When you handle paper, be sure to follow the information below to prevent any paper jams, print quality problems or printer damage;

- It is recommended to use long-grained paper for the best print quality. If short-grained paper is being used, it might be the cause of paper jams.
- Use neutral paper. Do not use acid paper to avoid any damage to the drum unit.
- Avoid using coated paper such as vinyl coated paper.
- Avoid using preprinted or highly textured paper.
- It is recommended to use labels or transparencies which are designed for use in laser printers.
- Avoid feeding labels with the carrier sheet exposed, or the printer will be damaged.
- Before loading paper with holes such as organizer sheets, be sure to fan the stack well.
- Do not use organizer sheets that are stuck together. The glue that is used might caused damage to the printer.
- When printing on the back of pre-printed paper, or if the paper is curled, be sure to straighten the paper as much as possible.
- Different types of paper should not be loaded at the same time in the paper cassette to avoid any paper jams or misfeeds.

3.6.2 Paper cassette capacity

(1) Maximum load height

Paper cassette:

<Normal paper>	Up to 27mm (1.06 inches) in height (250 sheets of 80 g/m ² A4/Letter paper)
<Transparencies>	10 sheets

(2) Paper feed conditions

Type	Weight	Cassette	Manual feed (1 sheet)
Normal paper (cut sheet)	64 to 105 g/m ²	○ (250 sheet)	○
	158 g/m ²	×	○
Special paper (cut sheet)	Labels	×	○
	Envelopes	×	○
	Organizers	×	○

3.6.3 Print Delivery

(1) Output tray stacking

capacity: Maximum 150 sheets (80 g/m²)
face-down only

(2) Straight paper path output to the rear of the printer

capacity: 1 sheet **Thicker paper printing is recommended.
Face-up only

NOTE:

- When using the straight paper path feed and the rear output method for thicker paper printing, lift up the rear cover at the rear of the printer.
- Face-down: Delivers the printed face of the paper downwards.
- Face-up: Delivers the printed face of the paper upwards.

3.7 Printing Area

3.7.1 Effective printing area

The effective printing area means the area within which the printing of all the data received without any omissions can be guaranteed.

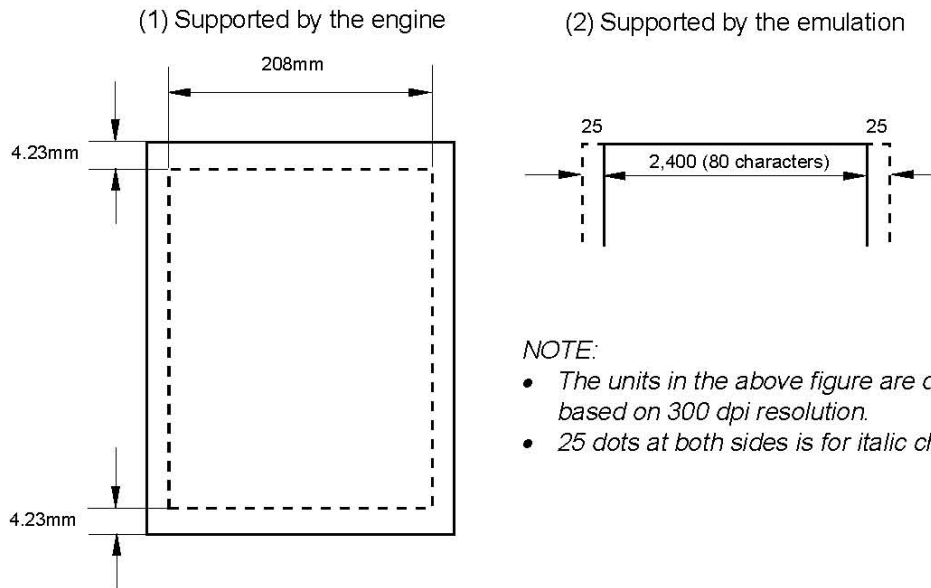

3.7.2 Print guaranteed area

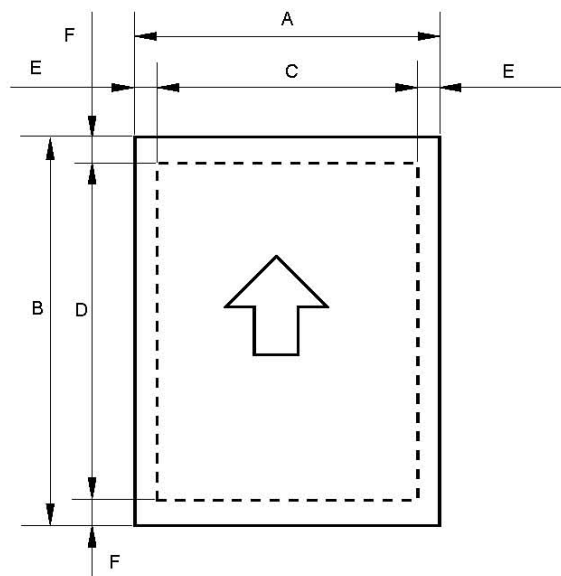

The values above vary depending on the paper size. For details, see the table on the next page.

The table below shows the print guaranteed areas for each paper size.

Size	A	B	C	D	E	F
A 4	210.0 mm 8.27" (2,480 dots)	297.0 mm 11.69" (3,507 dots)	203.2 mm 8.0" (2,400 dots)	288.5 mm 11.36" (3,407 dots)	3.4 mm 0.13" (40 dots)	4.23 mm 0.17" (50 dots)
Letter	215.9 mm 8.5" (2,550 dots)	279.4 mm 11.0" (3,300 dots)	203.2 mm 8.0" (2,400 dots)	270.9 mm 10.67" (3,200 dots)	6.35 mm 0.25" (75 dots)	↑
Legal	215.9 mm 8.5" (2,550 dots)	355.6 mm 14.0" (4,200 dots)	203.2 mm 8.0" (2,400 dots)	347.1 mm 13.67" (4,100 dots)	↑	↑
B 5 (ISO)	176.0 mm 6.93" (2,078 dots)	250.0 mm 9.84" (2,952 dots)	164.0 mm 6.46" (1,936 dots)	241.5 mm 9.5" (2,852 dots)	↑	↑
Executive	184.15 mm 7.25" (2,175 dots)	266.7 mm 10.5" (3,150 dots)	175.7 mm 6.92" (2,025 dots)	258.2 mm 10.17" (3,050 dots)	6.35 mm 0.25" (75 dots)	↑
A 5	148.5 mm 5.85" (1,754 dots)	210.0 mm 8.27" (2,480 dots)	136.5 mm 5.37" (1,612 dots)	201.5 mm 7.93" (2,380 dots)	6.01 mm 0.24" (71 dots)	↑
A 6	105.0 mm 4.13" (1,240 dots)	148.5 mm 5.85" (1,754 dots)	93.0 mm 3.66" (1,098 dots)	140.0 mm 5.51" (1,654 dots)	↑	↑
Organizer (J size)	69.85 mm 2.75" (825 dots)	116.0 mm 4.57" (1,370 dots)	56.2 mm 2.21" (675 dots)	107.5 mm 4.23" (1,270 dots)	6.35 mm 0.25" (75 dots)	↑
Organizer (K size)	95.25 mm 3.75" (1,125 dots)	171.45 mm 6.75" (2,025 dots)	86.78 mm 3.42" (975 dots)	162.98 mm 6.42" (1,925 dots)	↑	↑
Organizer (L size)	139.7 mm 5.5" (1,650 dots)	215.9 mm 8.5" (2,550 dots)	131.23 mm 5.17" (1,500 dots)	207.43 mm 8.17" (2,450 dots)	↑	↑
COM10	104.78 mm 4.125" (1,237 dots)	241.3 mm 9.5" (2,850 dots)	92.11 mm 3.63" (1,087 dots)	232.8 mm 9.16" (2,750 dots)	↑	↑
MONARCH	98.43 mm 3.875" (1,162 dots)	190.5 mm 7.5" (2,250 dots)	85.7 mm 3.37" (1,012 dots)	182.0 mm 7.16" (2,150 dots)	↑	↑
C 5	162 mm 6.38" (1,913 dots)	229 mm 9.01" (2,704 dots)	150.0 mm 5.9" (1,771 dots)	220.5 mm 8.68" (2,604 dots)	6.01 mm 0.24" (71 dots)	↑
DL	110 mm 4.33" (1,299 dots)	220 mm 8.66" (2,598 dots)	98.0 mm 3.86" (1,157 dots)	211.5 mm 8.33" (2,498 dots)	↑	↑

NOTE:

- The paper sizes indicated here should conform to the nominal dimensions specified by JIS.
- A4 paper must accommodate 80 characters printed in pica pitch (203.2 mm).
- The dot size is based on 300 dpi resolution.
- Organizer is not supported by any printer emulations (commands).

3.8 Documents

Only documents within the specifications below should be loaded into the automatic document feeder (ADF).

3.8.1 Feedable document

(1) Specification

	ADF	One page
Size	148 - 216 x 100 - 360 mm (5.8 - 8.5 x 3.9 - 14.1 in.)	148 - 216 x 100 - 360 mm (5.8 - 8.5 x 3.9 - 14.1 in.)
Thickness	0.07 - 0.12 mm	0.06 - 0.20 mm
Weight	64 - 90 g/m ² (17 - 24 lb.)	52 - 120 g/m ² (14 - 32 lb.)

(2) Document type & feeder capacity

Type	ADF Capacity
Normal paper	Approx. 30 sheets of 75 g/m ² (20lb.) * Approx. 30 sheets of 55 g/m ²
Envelope, Organizer	10 sheets

***NOTE:**

This specification is available only under the following environmental conditions:

- *Temperature:* 20 to 30 °C
- *Humidity:* 50 to 70% non-condensing

(3) Setting direction

Face down

3.8.2 Document delivery

(1) Method

300 dpi/step by clockwise rotation of the scanning stepper motor

196 dpi/step by counterclockwise rotation of the scanning stepper motor

(2) Document output capacity (on the document output flap)

Max. 30 sheets of A4 / Letter size paper

3.8.3 Scannable area

The physically scannable area is as shown in the figure below.

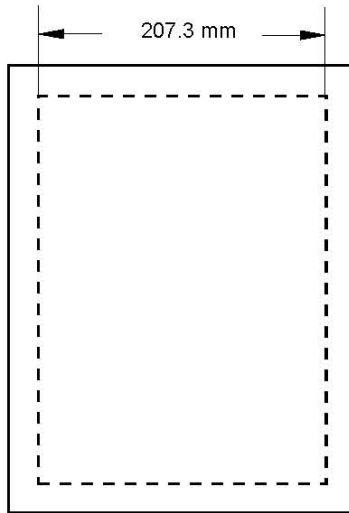

⚠ CAUTION:

When you handle documents, be sure to follow the information below to prevent any scanner errors or printer damage;

- *Do not load labels or transparencies in the document feeder.*
- *When loading multiple documents in the document feeder, load the same size and type of documents.*
- *When loading multiple documents in the document feeder, fan the documents before loading.*
- *When loading multiple documents in the document feeder, align the documents well. If the upper document is not aligned with the lower document, double feeding problems may occur.*
- *Documents printed in color might stain the scanning unit. If this happens, clean the scanning unit referring to [Subsection 3.5 'Cleaning the Scanning Unit' of CHAPTER 5](#).*

CHAPTER 2 INSTALLATION AND BASIC OPERATION

1. CONDITIONS REQUIRED FOR INSTALLATION

1.1 Power Supply

- The source voltage stays within $\pm 10\%$ from the rated voltage shown on the rating plate.
- The power cord, including extensions, should not exceed 5 meters (16.5 feet).
- Do not share the same power circuit with other high-power appliances, particularly an air conditioner, copier, shredder and so on. If it is unavoidable that you must use the printer with these appliances, it is recommended that you use an isolation transformer or a high-frequency noise filter.
- Use a voltage regulator if the power source is not stable.

1.2 Environment

- The printer should be installed near a power outlet, which is easily accessible.
- Maintain the room temperature between 10°C and 32.5°C and the relative humidity between 20% and 80%.
- The printer should be used in a well ventilation room.
- Place the printer on a flat, horizontal surface.
- Keep the printer clean. Do not place the printer in a dusty place.
- Do not place the printer where the ventilation hole of the printer is blocked. Keep a space of approximately 100 mm (4 inches) between the ventilation hole and the wall.
- Do not place the printer where it is exposed to direct sunlight. Use a blind or a heavy curtain to protect the printer from direct sunlight when the printer is unavoidably set up near a window.
- Do not place the printer near devices that contain magnets or generate magnetic fields.
- Do not subject the printer to strong physical shocks or vibrations.
- Do not expose the printer to open flames or salty or corrosive gasses.
- Do not place objects on top of the printer.
- Do not place the printer near an air conditioner.
- Keep the printer horizontal when carrying it.

1.3 System Requirements for Brother Printing Solution for Windows®

Check the following system requirements to setup and operate the printer in Brother Printing Solution for Windows:

- IBM PC or compatible with 80486 SX or higher microprocessor
- Parallel interface (or printer port) and/or USB interface (Windows® 98 only)
- 8MB or more of memory (for Windows® 3.1/3.11)
16MB or more of memory (for Windows® 95/98, Windows NT® 4.0)
- 10MB of space available on your hard disk for the printer and scanner drivers and all fonts
- 20MB of space available on your hard disk for PaperPort® for Brother software
35MB of space available on your hard disk for WordCraft UnimessagePro® software
- Microsoft Windows® 3.1/3.11, Windows® 95/98 or Windows NT® 4.0

2. UNPACKING

When unpacking the printer, check to see that all of the following components are included in the carton.

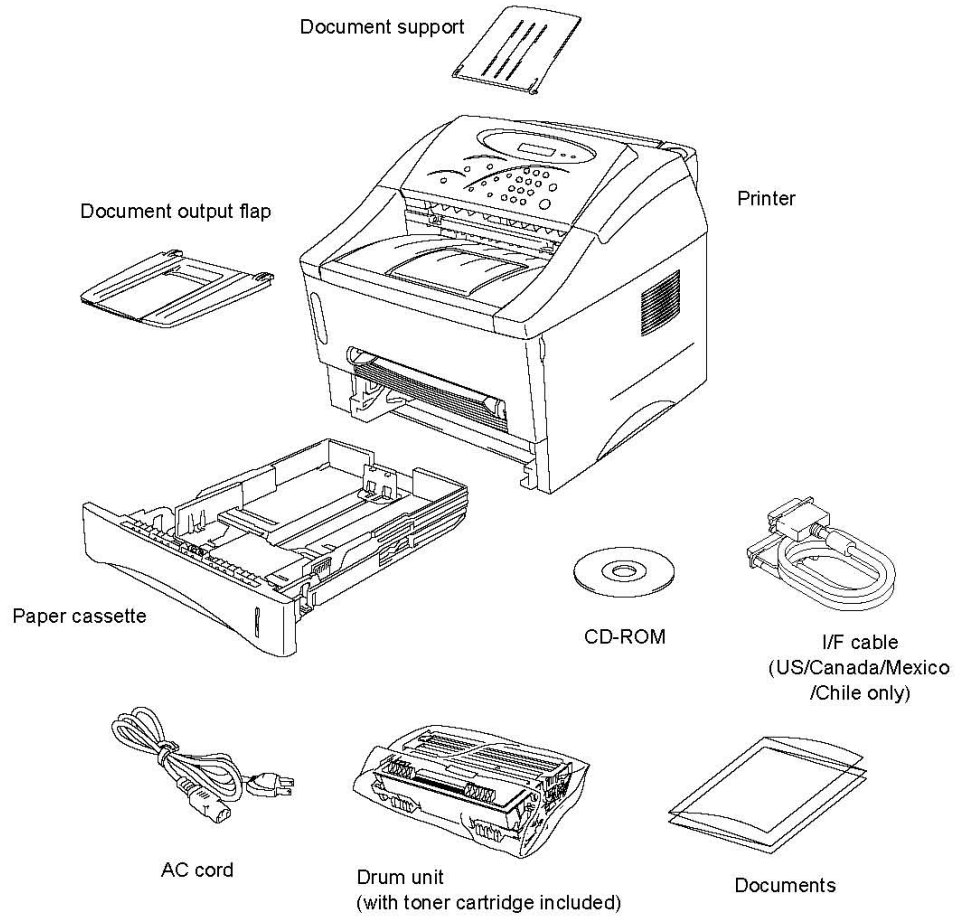

Fig. 2-1

NOTE:
Components vary depending on the country.

3. INSTALL THE PRINTER

You need to implement hardware setup and driver installation to use the printer.

Firstly, identify the Operating System on your computer. Then, purchase the appropriate interface cable (parallel or USB) for your computer.

The installation programs for the hardware setup and driver installation are contained on the supplied CD-ROM.

3.1 For Windows® Users

- (1) Turn on your PC power. Close all the applications running on your PC.
- (2) Insert the supplied CD-ROM into the CD-ROM drive.
- (3) The opening screen will appear automatically in Windows® 95/98/NT4.0.

NOTE:

If the opening screen does not appear:

*Click **Start** and select **Run**. Then, type `D:\START` in the command line box and click **OK**. (If your CD-ROM drive is not D, type the correct drive letter instead of "D".)*

In Windows® 3.1 in the Program Manager screen:

*Click the File menu and select **Run**. Then, type `D:\START` in the command line box and click **OK**. (If your CD-ROM drive is not D, type the correct drive letter instead of "D".)*

- (4) Select the language you require, then follow the instructions on the screen.



Fig. 2-2

- (5) Click the **Initial Setup** button.



Fig. 2-3

- (6) You can view the Initial Setup operations in the instructional video.
Follow each procedure to setup the printer hardware.



Fig. 2-4

- (7) Click the interface cable you are going to use, Parallel or USB.



Fig. 2-5

- (8) If you click the **Now** button, you can install the printer and scanner drivers and fonts immediately.
- (9) After the printer and scanner drivers have been installed, the P2500 window will appear. Follow the prompts to complete the installation.



Fig. 2-6

If your printer is connected using a parallel interface cable, the setup is now completed. If you want to connect your printer using a USB interface cable, refer to [Subsection 3.2 'Use the USB Interface \(For Windows® 98 only\)'](#).

3.2 Use the USB Interface (for Windows® 98 only)

The steps in this section are essential for USB interface cable users.

Follow the CD-ROM instructions, **step (1) to (6) in the previous section** of these instructions.

3.2.1 Connect the USB interface cable

- (1) Check that the printer power switch is on.
- (2) Connect the USB interface cable to the computer, then connect it to the printer. (Fig. 2-7)

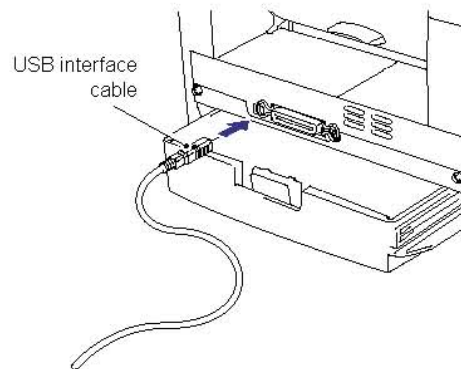

Fig. 2-7

3.2.2 Install the USB driver

- (1) After connecting the USB interface cable, the dialog box shown right will appear on your PC screen. Click the **Next** button.



Fig. 2-8

- (2) Select "Search for the best driver for your device." Click the **Next** button.



Fig. 2-9

- (3) Select "Specify a location" and remove the other check marks. Click the **Browse** button to locate the file.



Fig. 2-10

- (4) Double-click the CD-ROM icon and click on the **Win98usb** folder. Click **OK** button.
- (5) Click the **Next** button on the following two windows. The USB driver will be installed.

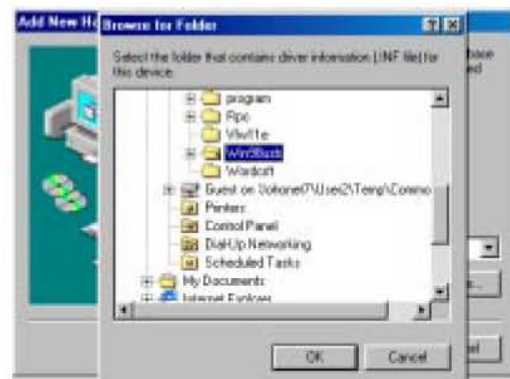

Fig. 2-11

- (6) Click the **Finish** button. Go to the next step to install the scanner driver.
- (7) Repeat steps (1) to (6) to install the scanner driver.
- (8) Repeat steps (1) to (5) to install the printer driver.



Fig. 2-12

- (9) The following screen appears after installing all the drivers. Select the "BRUSB USB Printer Port".

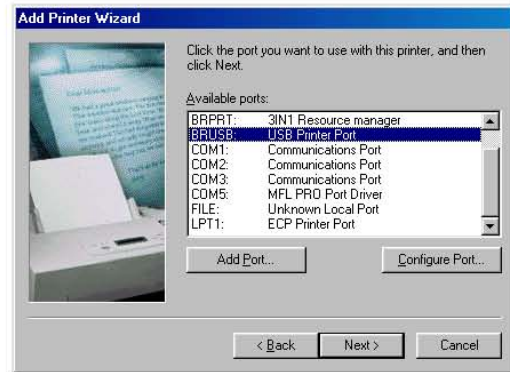

Fig. 2-13

- (10) Click the **Yes** button, then click the **Finish** button.

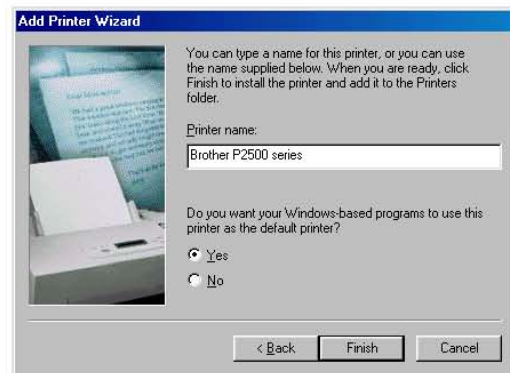

Fig. 2-14

- (11) Select a language and click **OK** button, then click the **Finish** button. The setup is now completed.

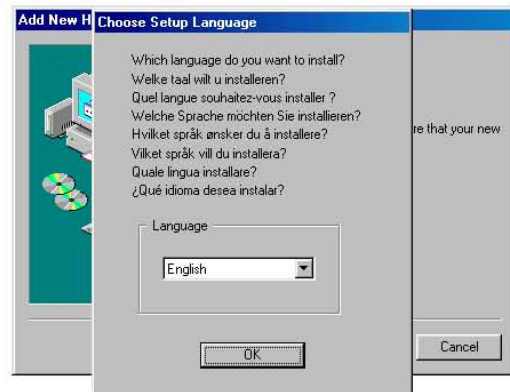

Fig. 2-15

3.3 For Macintosh (iMac and Power Macintosh G3 with USB) Users Only

You can setup the printer following the Initial Setup instructions on the supplied CD-ROM.

- (1) Turn on the computer power, then insert the CD-ROM into the CD-ROM drive. The window shown below will appear automatically.



Fig. 2-16

- (2) Click the "Instructional Video" icon in the window above to view the Initial Setup operations in the video movie.
- (3) Click the "Printer Driver Installer" icon in the window above to install the printer driver.
- (4) Click the "Scanner Driver Installer" icon in the window above to install the scanner driver.
- (5) Open the Chooser from the Apple menu.



Fig. 2-17

- (2) Click the scanner driver you just installed to highlight it. Click the printer to which you want to print on the screen. Close the Chooser.

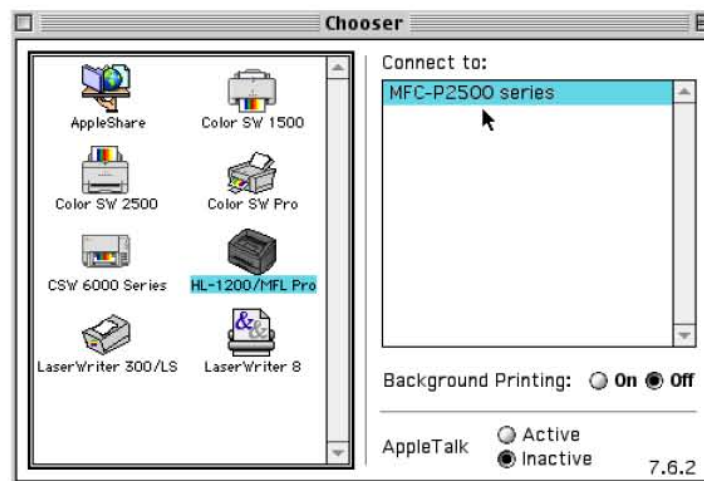

Fig. 2-18

4. PAPER HANDLING

The printer provides two types of paper loading method; paper cassette and manual feed slot.

4.1 Load Paper into the Paper Cassette

You can load normal paper and transparencies into the paper cassette as in the steps below. If you load paper into the paper cassette, the printer automatically feeds paper sheet by sheet and ejects the printed page into the output tray.

- (1) Pull the paper cassette completely out of the printer.
- (2) Adjust the paper guides to the paper size. (Fig. 2-19)

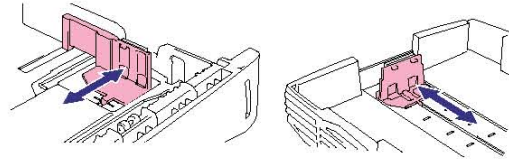

Fig. 2-19

- (3) Load paper. Check that paper is flat in the cassette at all four corners. (Fig. 2-20) Paper should be loaded up to the lines on the sliding guide.
- (4) Re-install the paper cassette into the printer.

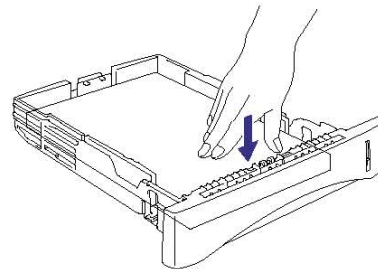

Fig. 2-20

For the details on feedable paper into the paper cassette, refer to [Subsection 3.6 'Paper' in CHAPTER 1](#).

4.2 Load Paper Manually

You can feed envelopes, labels and organizers as well as normal paper and transparencies into the manual feed slot. (For details on feedable paper, see [Subsection 3.6 'Paper' in CHAPTER 1](#).)

When using the manual feed slot, follow the steps below;

- (1) Select the manual feed mode in the printer driver, and send the print data to the printer.
- (2) Set the width of the manual feed slot paper guides using both hands to the paper width to be used. (Fig. 2-21)

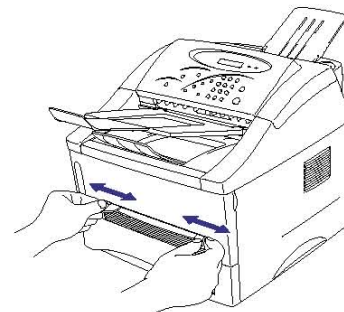

Fig. 2-21

- (3) Insert the paper into the manual feed slot with both hands until the front edge of the paper touches the paper feed roller.
- (4) Hold the paper in this position until the printer feeds the paper in automatically a short distance and then let go of the paper. (Fig. 2-22)

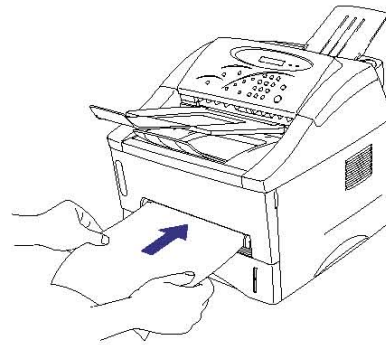

Fig. 2-22

- (5) After the printer ejects the printed page, insert the next sheet of paper as in the previous step. The printer will wait until you insert the next sheet of paper. Repeat this as necessary for the number of pages you need to print.

NOTE:

It is recommended to remove printed pages immediately after printing if the output tray extension flap is not extended.

The printer has a **straight paper path** from the manual feed slot to the rear of the printer when the rear cover is lifted upwards. Use this paper feed and output method when printing on thicker paper or card.

- (1) Select the manual feed mode in the printer driver.
- (2) Lift up the rear cover at the rear of the printer. (Fig. 2-23)
- (3) Send the print data to the printer.
- (4) Follow Steps (3) to (4) above to load paper.
- (5) Close the rear cover of the printer.

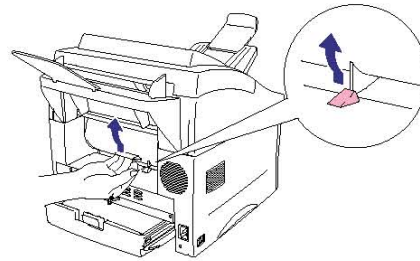

Fig. 2-23

CAUTION:

Remove each sheet immediately after printing. Stacking the sheets may cause curl or media feed jams.

4.3 Two Side Printing (Manual Duplexing)

The supplied printer drivers enable manual duplex printing.

When using the manual duplexing function, note the following cautions;

CAUTION:

- *If the paper is too thin, it may cause wrinkling.*
- *If paper is curled, straighten it and then set it into the paper cassette.*
- *The paper type should be regular paper. Do not use bond paper.*
- *When setting paper into the paper cassette, empty the cassette first, then insert the printed paper only, printed side face up. (Do not add the printed paper onto the top of the unprinted paper stack.)*
- *If the paper is not feeding correctly, the paper might be curled. Remove the paper and straighten it.*

4.3.1 Print on both sides of paper from the paper cassette

- (1) Select the required manual duplex printing mode from the driver.
- (2) The printer will automatically print all the even numbered pages on one side of the paper first.
- (3) Remove the printed even numbered pages from the output tray.
- (4) Re-insert them into the paper cassette, loading the paper with the side to be printed (blank side) face down, and the top edge toward you. Follow the instructions on the computer screen. (Fig. 2-24)
- (5) The printer will now automatically print all the odd pages on the reverse side of the paper.

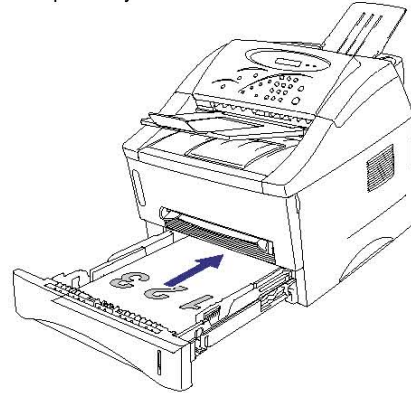

Fig. 2-24

4.3.2 Print on both sides of paper from the manual feed slot

- (1) Select the required manual duplex printing mode and manual feed mode from the driver.
- (2) Using both hands, insert the paper into the manual feed slot with the side to be printed first facing upwards. Follow the instructions on the computer screen.
- (3) Repeat action (2) until you have printed all the even numbered pages.
- (4) Remove the printed even numbered pages from the output tray
- (5) Re-insert them in order into the manual feed slot, loading the paper with the side to be printed (blank side) face up, and the top edge towards the printer. Follow the instructions on the computer screen. (Fig. 2-25)
- (6) Repeat action (5) until you have printed all the odd pages on the reverse side of the paper.

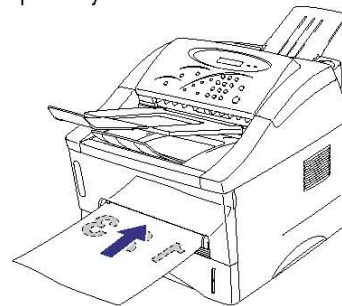

Fig. 2-25

NOTE:

- Before re-inserting the sheet, straighten them, or paper feed errors will occur.
- The use of very thin or very thick paper is not recommended.

5. CONTROL PANEL OPERATION

There are twelve buttons, one set of 10 keys, three LEDs and one 16-segment LCD on the control panel. The LEDs and the message on the LCD indicate the current status of the printer and pressing each button enables control of the various functions incorporated in the printer.

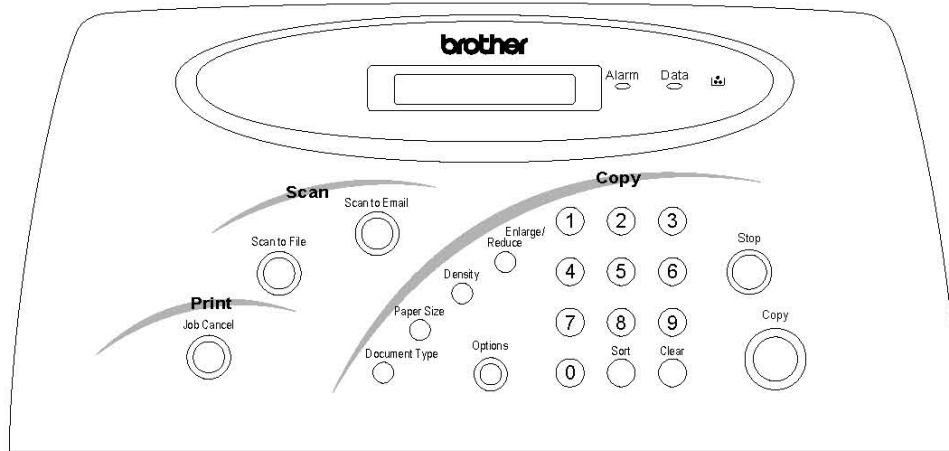

Fig. 2-24

5.1 LED Indications

Three LEDs indicate the printer status with a message on the LCD as follows;

LED		Descriptions
Alarm	ON	An error listed below has occurred. Cover open / Memory full / Paper empty / Misfeed / Paper jam / Machine error / Document jam
Data	Blinking	The printer is receiving data from the computer or the printer is processing data in memory.
	ON	Data still remains in the buffer memory.
Toner	Blinking	The toner cartridge is nearly empty.
	ON	The toner cartridge is empty.

5.2 Button Functions

The twelve buttons and one set of 10 keys are categorized to control the Print, Scan, and Copy functions as shown in figure (Fig. 2-26) in the previous page.

Button	Functions
Job Cancel	<ul style="list-style-type: none"> • Stops and cancels the print operation in progress and ejects the paper. • Prints any data remaining in the printer memory. • Clears a Memory Full error and continues printer operation. • Switches to paper cassette feeding when sending the data in 'Manual' feed mode.
Scan to File	Starts scanning of the original document into a file in the viewer software on your PC.
Scan to Email	Starts scanning of the original document into your e-mail software.
Copy	Starts copying. After finishing copying, the printer goes back to ready status.
Stop	Stops and cancels the copy operation in progress. The original document and printed sheet will be ejected.
Enlarge/Reduce	Makes selection of an enlarge/reduce ratio for copy.
Density	Sets the print contrast for the copied documents.
Paper size	Selects the size of the printed sheet for copy.
Document Type	Changes the copy mode, Photo/Text, Photo or Text.
Options	Sets the layout on the print sheet for copy.
Sort	Selects the copy order, Sort or Stack, when copying two or more documents.
Clear	Returns all the settings to the default.
10 keys	Set the number of copies. The maximum number of copies is 250.

NOTE:

All the settings other than paper size are returned to the default after copying. The paper size setting is stored in NVRAM.

5.3 LCD Indications

5.3.1 Normal mode

The messages shown on the LCD display indicates the printer status.

For printer, scanner & copier

LCD Message	Descriptions
SLEEP	The printer is in sleep mode.
READY	The printer is in ready status.
READY COPY/SCAN	The printer is in ready status, and the document is set in the document feeder.
PLEASE WAIT	The printer is warming up.
CHANGE DRUM SOON	The drum unit is nearly at the end of life. This message appears for one minute.
TONER LOW	Toner cartridge is nearly empty.
TONER EMPTY	There is no toner in the toner cartridge.
COOLING DOWN	The printer is cooling down because the temperature inside the printer exceeded the specified level.
COVER OPEN	The front cover is open.
CHECK CASSETTE CHECK CASSETTE #1 CHECK CASSETTE #2	The paper cassette is not installed. (When the optional lower tray is installed, 'CHECK PAPER#1' or 'CHECK PAPER#2' appears.)
CHECK PAPER CHECK PAPER#1 CHECK PAPER#2	There is no paper in the paper cassette. (When the optional lower tray is installed, 'CHECK CASSETTE #1' or 'CHECK CASSETTE #2' appears.)
PRINTER JAM	The printed paper is jammed.
NO DOCUMENT	No document is set in the document feeder.
NO DATA!	There is no data remaining in the printer memory.
DOCUMENT JAM	The scanned document is jammed, or a document loading error occurred.
MACHINE ERROR XX	A service error occurred.
MEMORY FULL	A memory full error occurred.
STOP KEY PRESSED	The Stop button was pressed.
PRESS STOP KEY	The current operation will be cleared by pressing the Stop button.
REPLACE DRUM?	Reset the drum counter.
ACCEPTED	The printer accepted the button/key press.
PLS OPEN COVER	A machine error which may be cleared by opening/closing the front cover occurred.
PLS CLEAN DRUM	<ul style="list-style-type: none"> After 3,000 pages are printed. The printer prints out the drum cleaning message at the same time. The printer has detected a corona discharge.

For printer

Indication	Descriptions
PRINTING	The printer is printing the data.
MANUAL FEED	The printer is waiting for paper to be inserted in manual mode.
REMAINED DATA	Data is remaining in the printer memory.

For scanner

Indication	Descriptions
SCAN TO FILE	The printer starts scanning by pressing the Scanner button.
SCAN TO E-MAIL	The printer starts scanning by pressing the E-mail button.
SCANNING	The printer is scanning the document.

For copier

Indication	Descriptions
COPYING P. XX	The printer is copying the document.
COPY STACK (SORT) P. XX	The printer is copying two or more document while stacking (or sorting) them.
NO. OF COPIES: XXX	Number of copies set.
SORT COPIES: XXX	Number of copies when sorting.
DOC TYPE: PHOTO (TEXT, TXT/PH)	Mode setting (Photo/Text, Photo or Text)
ENLARGE / REDUCE: XXX%	Scale setting (Enlarge or Reduce)
SORT: XXX	Sort mode setting (Sort or Stack)
LAYOUT: XXX	Layout setting (Normal, 2 in 1, 4 in 1, 1 in 2x2, or 1 in 3x3)
PAPER: XXX	Paper size setting (Letter, Legal, Executive, A4, B5, A5, A6, B6)
SETTING CLEARED	All the settings for copying are cleared.
OUT OF RANGE	The setting value is out of range.
COPY TO COPY	The printer stops copying because of a memory full error.
OPTION CASSETTE	The optional cassette is installed.
NO OPT. CASSETTE	No optional cassette is installed.
CASSETTE #1/#2?	Select the paper cassette, #1 or #2.
USE CASSETTE #1/#2	Paper is fed from the paper cassette #1 or #2.

NOTE:

For troubleshooting the error messages, refer to [Section '2.1 Error Messages on the Control Panel' in CHAPTER 7.](#)

5.3.2 Test print mode

Turning on the printer while pressing the **Job Cancel** button makes the printer enter into test print mode. Then, press the specified key of the 10 keys to select the test print mode.

10 key	Test print mode	Descriptions
1	TEST PRINT	Prints a test pattern.
2	PRINT CONFIG	Prints Print Configuration.
3	PRINT FONTS	Prints a font list.
4	HEX DUMP	Prints hexadecimal data.
5	FACTORY RESET	Returns to the factory settings and turns the printer power switch on.
6	DRUM LIFE	Indicates the remaining drum life.

NOTE:

For the details on the above messages, refer to *Section '1. TEST PRINT MODE' in CHAPTER 6.*

6. COPYING OPERATIONS

The printer allows you to make high-quality photocopies. Always make sure that paper is loaded into the paper cassette before making copies.

6.1 How to Copy

Copy the document following the steps below;

- (1) Set the width of the document feeder paper guides using both hands to the paper width to be used.
- (2) Insert the original document face down in the document feeder. (Fig. 2-25)

The following message appears on the control panel to indicate that it is ready to copy or scan.

READY COPY/SCAN

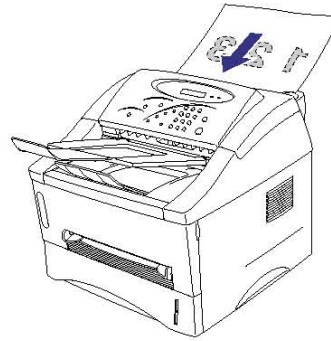

Fig. 2-25

NOTE:

When you make a copy onto paper fed from the manual feed slot, insert the print sheet of paper into the manual feed slot after setting your original documents.

- (3) You can select the settings, Enlarge/Reduce, Density, Document type, Paper size and Options with the buttons on the control panel. For details on each setting, refer to [the following section](#).

NOTE:

- All these settings will be cleared after pressing the **Copy** button except the paper size setting.
- You can reset all settings except the paper size setting to their defaults for copying if you press the **Clear** button before copying.

- (4) Use the **10 numeric keys** to set the required number of copies on the display.

NO.OF COPIES: 003

When you have selected more than 2 copies, you can choose the STACK or SORT options by pressing the **Sort** button.

SORT: STACKED

- (5) Press the **Copy** button. If you want to stop copying, press the **Stop** button.

6.2 Settings for Copy

The settings for copying are effective only for the next copy and after that the settings are cleared. The number of copies should be set last after the following settings have been made. However, the paper size setting, optional paper cassette installation and paper cassette selection (#1 or #2) are stored in NVRAM.

6.2.1 Enlarge/Reduce

You can make an enlarged or reduced size of copy by pressing the **Enlarge/Reduce** button to select an enlargement or reduction ratio.

The ratio varies depending on the country as follows;

Country	Enlargement / Reduction
USA/Canada	100% > Manual > 120% > 150% > 200% > 78% > 50% > Auto
Others	100% > Manual > 122% > 141% > 200% > 87% > 71% > 50% > Auto

You can set a reduction or enlargement ratio from 50 to 200% by using the **10 numeric keys** while 'MANUAL' is displayed on the LCD.

Setting a value out of this range will produce an error message on the LCD.

The Enlarge/Reduce function works as shown in the figure below;

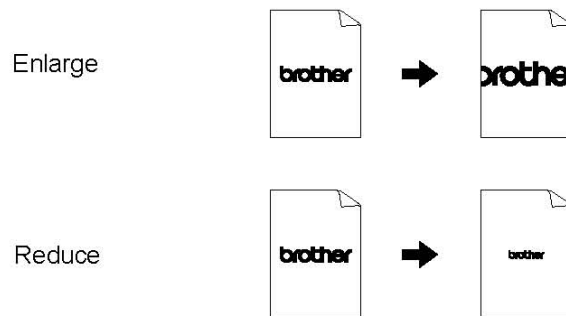

Fig. 2-26

If the original document is larger than the print sheet size, you can change the reduction ratio automatically.

The AUTO setting allows you to change the reduction ratio automatically to make the original document print in the printable area of print sheet size A4, Letter, B5, A5 and B5. Use the **Paper size** button to select the size of the printed sheet.

For more information, see subsection 6.2.5 'Paper size' in this chapter.

6.2.2 Document type

Select the original document type from TEXT, PHOTO and TEXT/PHOTO. Each mode is defined as follows;

- TEXT: Select when the original document does not contain photographic images.
- PHOTO: Select when the original document contains only photographic images.
- TEXT/PHOTO: Select when the original document contains both text and photos.

6.2.3 Density

Adjust the density by pressing the **Density** button to alter the number of blocks on the display as shown below ;

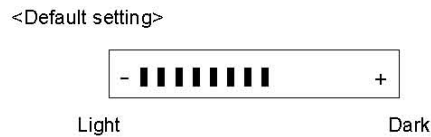

6.2.4 Options

Makes copies and changes the layout on the print sheet, 2 in 1, 4 in 1, 1 in 2x2 or 1 in 3x3.

Before pressing the **Copy** button, select the paper size setting to match the size of paper in the paper cassette.

6.2.5 Paper size

Changes the paper size to match the size of the paper in the paper cassette or being loaded from the manual feed slot for copy.

Paper size: Letter, Legal, A4, B5, A5, A6, B6, Executive

NOTE:

- The paper size selection is effective only when you copy using 'Enlarge/Reduce' copy or 'Options'.
- If the optional lower paper cassette is installed onto the printer, the panel settings are different for the lower cassette as follows;
 - i) Press the **Paper size** button while pressing the **Stop** button. The 'OPTION CASSETTE' message appears on the LCD.
 - ii) Press the **Paper size** button again, then 'USE CASSETTE #2' message appears on the LCD.
 - iii) Press the **2** button of the **10** numeric key and select the paper size for the lower tray unit using the **Paper size** button.

6.2.6 Sort

Select STACK or SORT when making multiple copies.

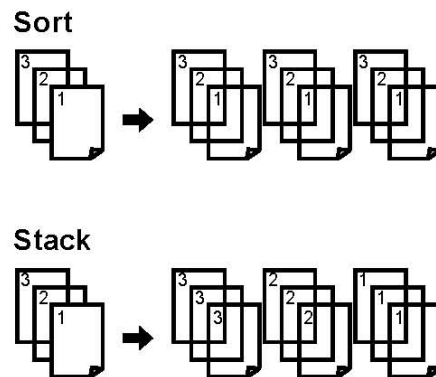

Fig. 2-29

7. SCANNING OPERATIONS

When the scanner driver has been installed, you can use the printer as a scanner from any TWAIN compliant application such as Adobe Photoshop.

Note that the scanning operations differs depending on the printer models.

7.1 Scanning from the PaperPort® for Brother Software (for USA/Canada)

- (1) Launch the PaperPort® for Brother software.
- (2) Click the **Twain** icon. The scanner driver dialog box is launched.
- (3) Make the settings you required.
- (4) Press the **Start** button. The scanned image will be shown on the desktop with the name 'Untitled-x'.

For further information about 'PaperPort', refer to the On-line Help in the application.

NOTE:

- *It is recommended that "MFL ProControl Center" and "Brother 3in1 Resource Manager" always run when you use the scan function.*
- *Make sure that Select source in the File menu of your application selects the 'TWAIN_32 Brother P2500' if you have had a scanner application other than the Brother Twain driver installed previously.*

7.2 Scanning from the Unimessage™ Pro Viewer Software (for Other Countries than USA/Canada)

- (1) Launch the Unimessage™ Pro Viewer software.
- (2) Click the **Scan to file** button, the 'Scan multiple pages' window appears on your PC.
- (3) Press the **Scan** button on the Scan multiple pages window and the Scanner Setup window appears.
- (4) Adjust the following settings, if need, in the Scanner Setup window:
 - Resolution
 - Gray Scale (Black & White, Gray [Error Diffusion], True Gray)
 - Brightness
 - Contrast
 - Size
- (5) Click the **Start** button on the Scanner Setup window.
- (6) If required repeat steps (2) to (5) to scan more pages.
- (7) Select the pages from the left column you want to use and click the **Add** button to include them in your document then click the **OK** button.

The scanned image will be shown in the Unimessage Pro 'Scanned images' folder.

NOTE:

- *It is recommended that the "Brother 3in1 Resource Manager" is always running when you use the scan function.*
- *Make sure that 'Select Source' in the File menu in your application is selected to the P2500 if you have had another scanner application installed other than the Brother HL-P2500.*

7.3 Scanning from TWAIN Compliant Applications

The printer provides you with a TWAIN compliant scanner driver. This allows you to use the printer as scanner from any TWAIN compliant application such as PaperPort / Unimessage and Adobe Photoshop.

- (1) Launch the application you wish to use.
- (2) Select the 'Select Source' menu.
- (3) Select the "TWAIN_32 Brother P2500" or 'Brother P2500' and click Select.
- (4) Select the "Acquire" menu.
- (5) Make the appropriate settings such as;
 - Scanning Resolution
 - Scanning Area
 - etc...
- (6) Click the **Start** button.

NOTE:

- *Selecting the exact scanning area reduces the scanning data so that you can save transfer time and memory.*
- *Generally, the scanning resolution should be set according to the final output device. For example, when the output device is a monitor screen, 150 dpi scanning is enough. If a higher scan resolution is chosen the displayed output may not have any particular improvement.*

7.4 Scanning from Control Panel Operation

Pressing the **Scan to File** or **Scan to Email** button on the control panel also allows you to scan the documents.

The scanning operation differs depending on the printer model.

NOTE:

<MFC-P2500>

When the "MFL ProControl Center" and "Brother 3in1 Resource Manager" are not running in the Task Tray, the buttons for 'Scan to File' and 'Scan to Email' do not work. Please use these functions after running these programs.

<HL-P2500>

*When the "Brother 3in1 Resource Manager" is not running in the Task Tray, the **Scan to File** and **Scan to Email** buttons do not work. Use these functions after making sure the Resource Manager program is running.*

7.4.1 Pressing the Scan to File button for MFC-P2500

- (1) Insert the original document face down in the document feeder.
- (2) The "Brother MFL ProControl Center" window appears on your PC.
- (3) Press the **Scan to File** button.

NOTE:

*When you change the saving location for the scanned data, select the location by pressing the **Scan to File** button in 'Brother MFL ProControl Center'.*

7.4.2 Pressing the Scan to Email button for MFC-P2500

- (1) Insert the original document face down in the document feeder.
- (2) Press the **Scan to Email** button.
- (3) The mailer launches automatically with the file you scanned attached to the mail.

7.4.3 Pressing the Scan to File button for HL-P2500

- (1) Insert the original document face down in the document feeder.
- (2) Press the **Scan to File** button. The scanned images at 300 dpi in Black and White will be shown in the Unimessage Pro 'Scanned images' folder.

7.4.4 Pressing the Scan to Email button for HL-P2500

This function is used to quickly send images of your documents to people via email using your MAPI compatible email application.

- (1) Insert the original document face down in the document feeder.
- (2) Press the **Scan to Email** button. Unimessage Pro will start a new message in your MAPI compatible email application with the scanned image at 300 dpi in Black and White automatically attached.

CHAPTER3 THEORY OF OPERATION

1. ELECTRONICS

1.1 General Block Diagram

Fig. 3-1 shows a general block diagram of the printer.

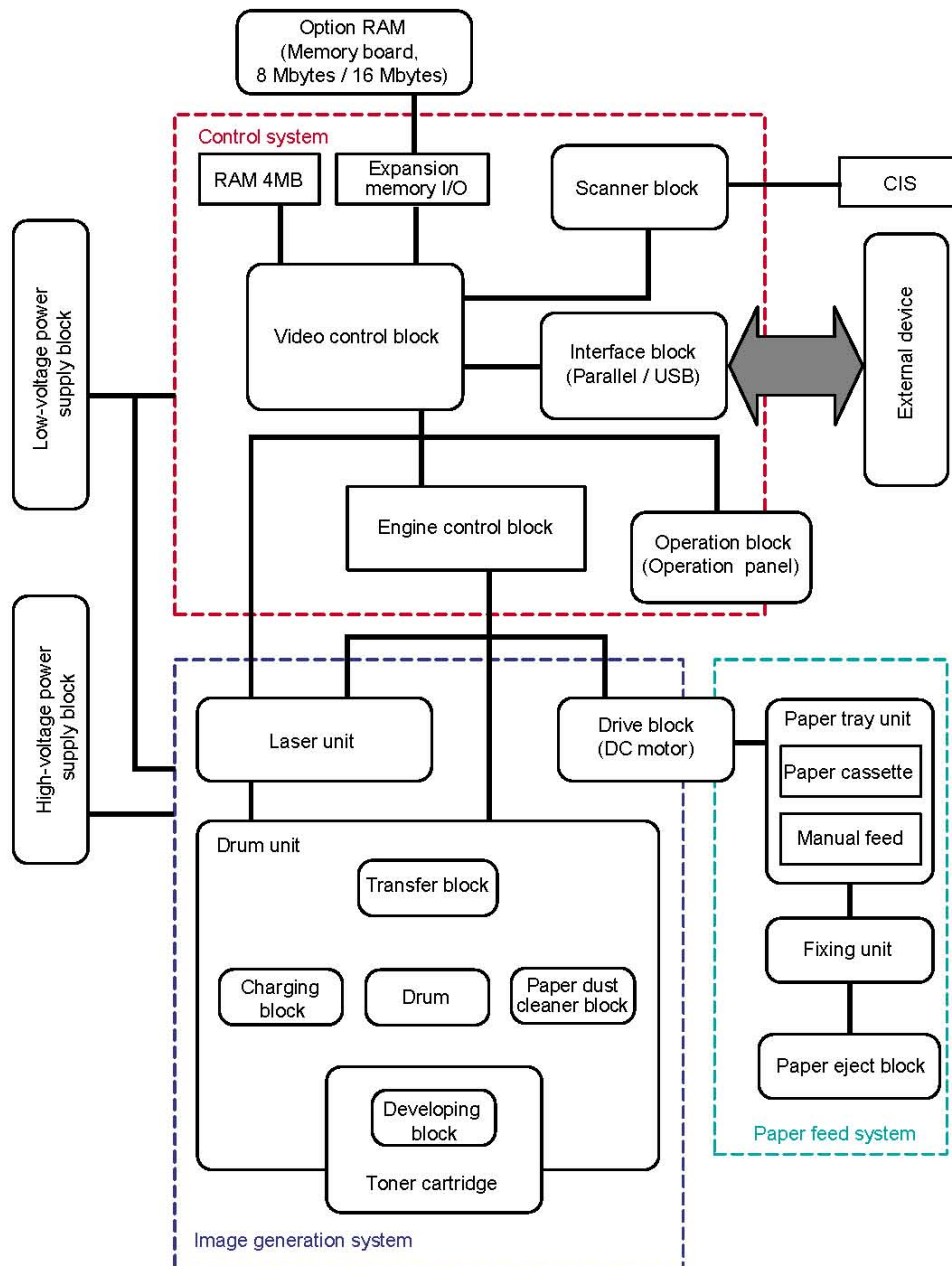

Fig. 3-1

1.2 Main PCB Block Diagram

Fig. 3-2 shows the block diagram of the main PCB of the printer.

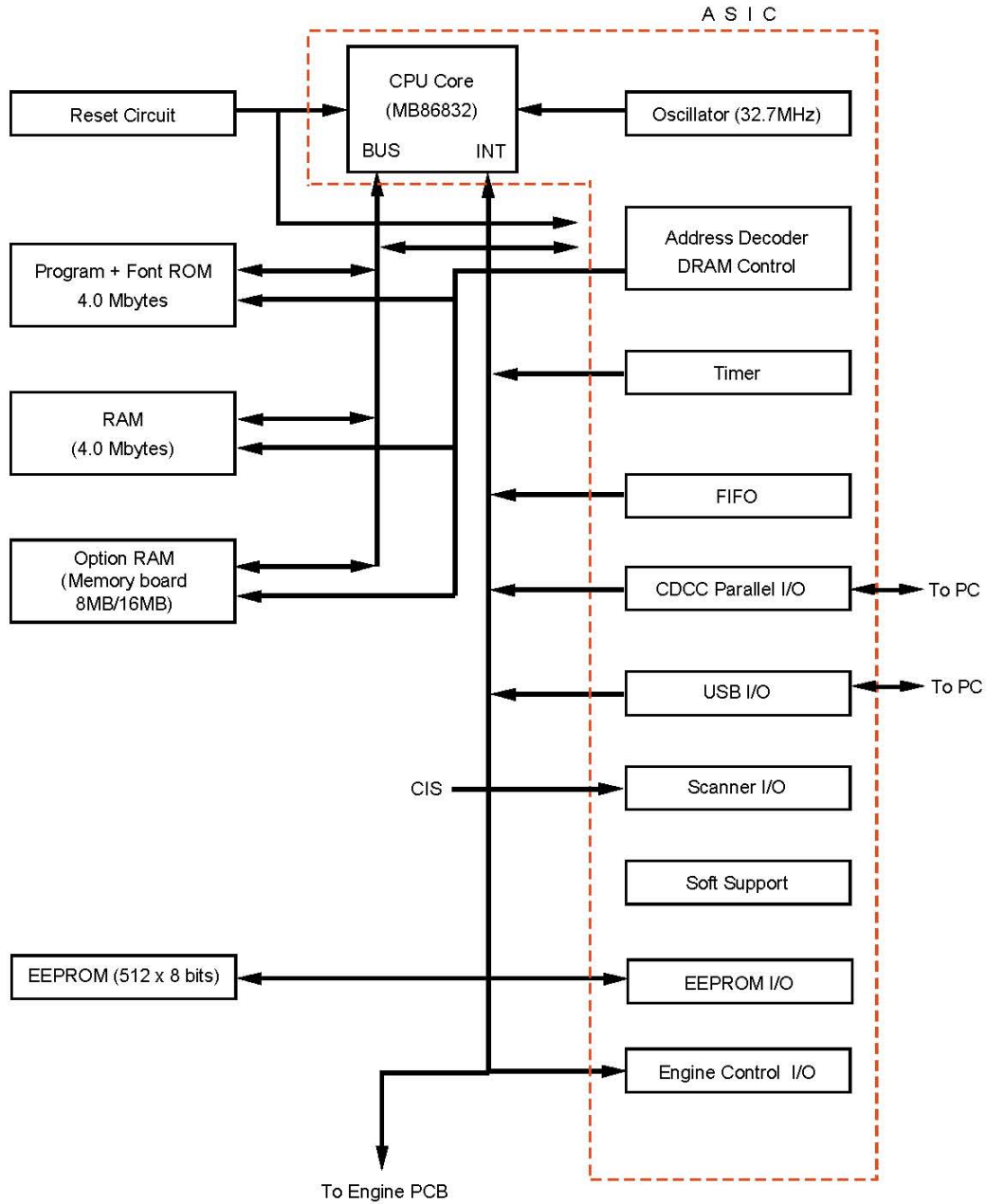

Fig. 3-2

1.3 Main PCB

For the entire circuit diagram of the main PCB, see [APPENDIX 8 to 10](#).

1.3.1 ASIC

A Fujitsu 32bit RISC CPU, MB86832 (SPARC lite) is built into the ASIC. While the CPU is driven with a clock frequency of 33 MHz in the user logic block, it itself runs at 66 MHz, which is made by multiplying the source clock by two.

The functions of the interface block communications with the external devices are described below;

(1) IEEE1284

Stores the data received from the PC into DRAM via the DMA controller. It supports both normal receiving and bi-directional communication (nibble mode, byte mode, ECP mode).

(2) USB interface

Stores the data received from the PC into DRAM via the DMA controller. The transmission speed is 12Mbps.

(3) Engine GA transfer circuit

Communicates with the engine GA by a full-duplex synchronous serial method. The communication speed is 2Mbps.

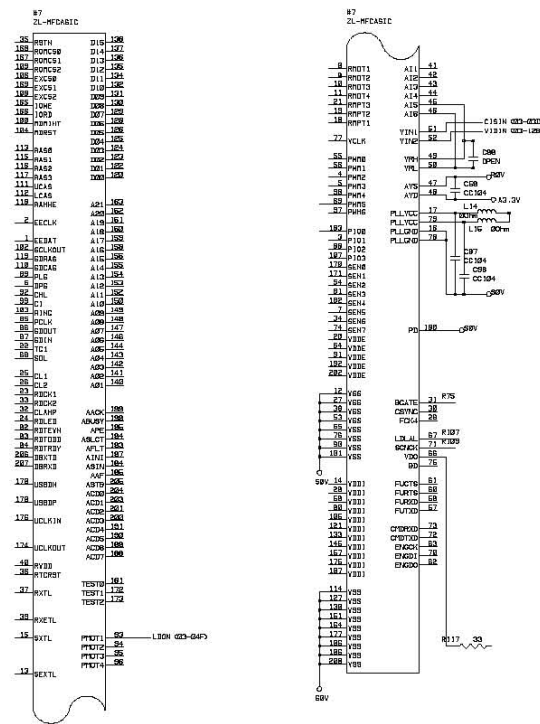

Fig. 3-3

1.3.2 ROM

32 Mbits of ROM (x 16 bit) are fitted.

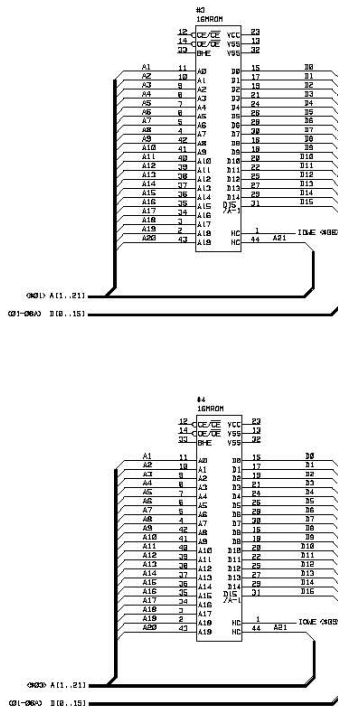

Fig. 3-4

1.3.3 DRAM

Two 16M-bit DRAMs (x 16 bits) are used as the RAM.

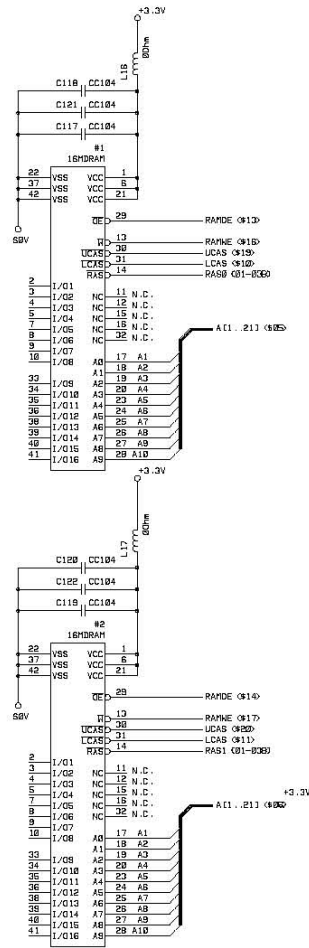

Fig. 3-5

1.3.4 EEPROM

The EEPROM is a 24C04 type using the two-wire method with a 512 x 8 bits configuration.

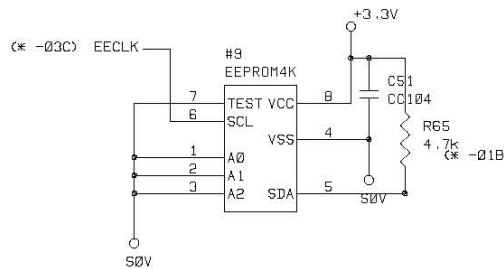

Fig. 3-6

1.3.5 Reset circuit

The reset IC is a RN5VD42A. The reset voltage is 4.2V (typ.) and the LOW period of reset is 80ms (typ.)

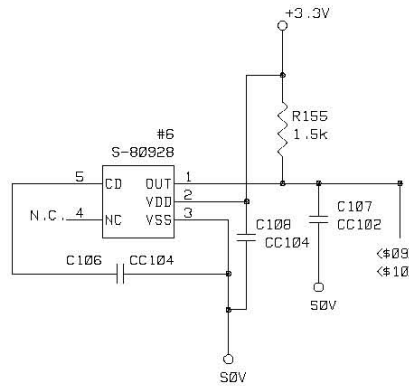

Fig. 3-7

1.3.6 Engine I/O

Fig. 3-8 shows the engine interface circuit. The interface with the engine PCB is by full-duplex synchronous serial method.

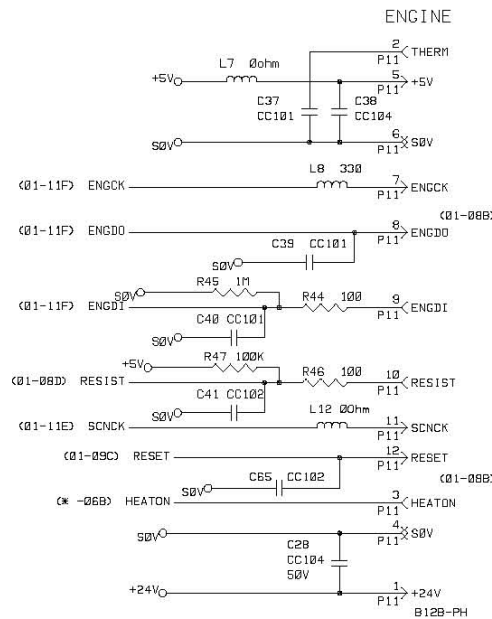

Fig. 3-8

1.3.7 Scanner panel I/F

The scanner panel interface is a serial interface. The rear sensor is directly connected to the ASIC.

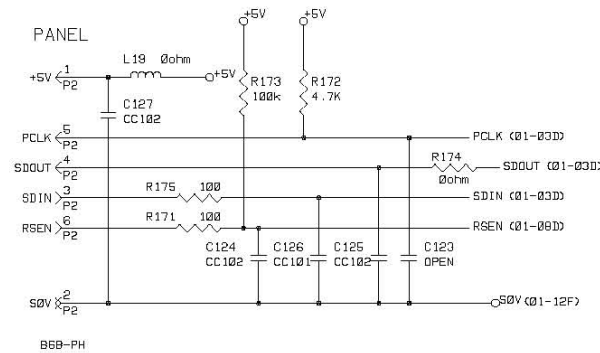

Fig. 3-9

1.3.8 Scanner motor drive circuit

The scanner motor is controlled by a unipolar constant current control device. The combination of the current flow and the phase excitation method is changed depending on the scanner motor speed.

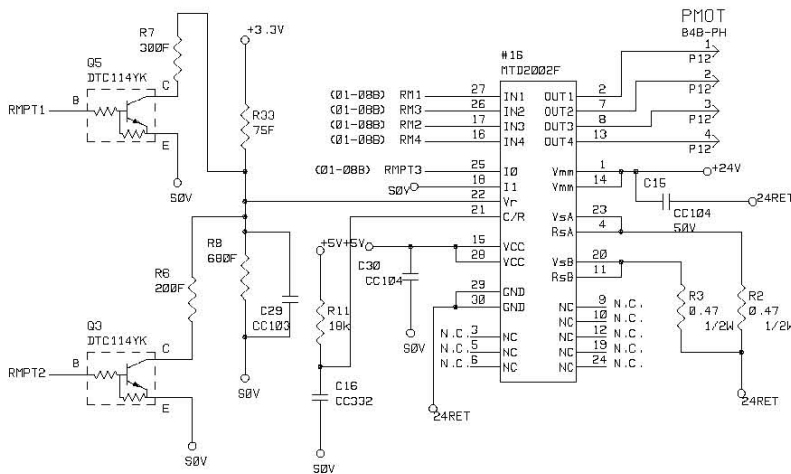

Fig. 3-10

1.3.9 CIS drive circuit

The current to the CIS LED is controlled by PWM. The analog signal from the CIS is input into the ASIC, MB87L1011.

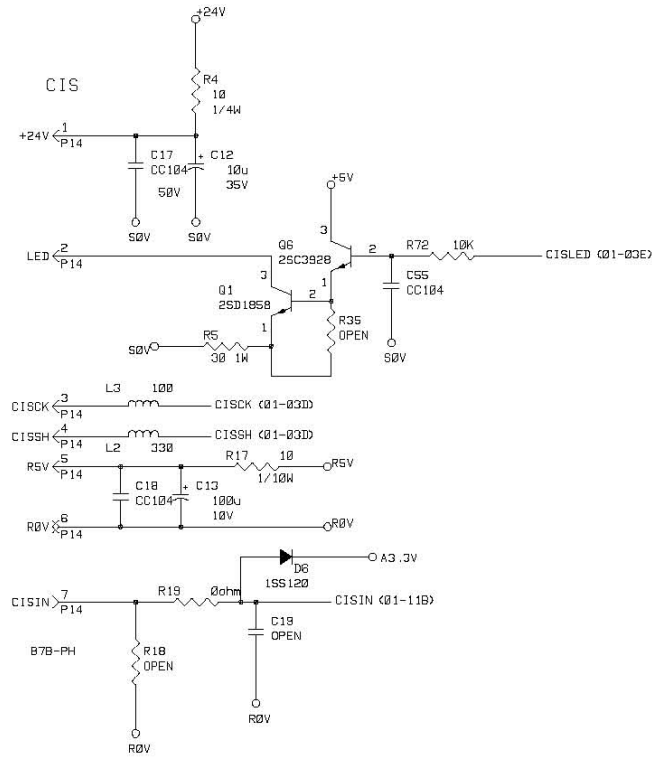

Fig. 3-11

1.4 Engine PCB

The gate array which transforms the serial signal from the main PCB into the parallel signal is mounted on the engine PCB.

The engine PCB controls the following parts by the transferred signal;

- Main motor
- Fan motor
- Thermistor
- Polygon motor
- Solenoid
- Toner sensor
- Cover sensor
- Front registration sensor
- Rear registration sensor
- Upper paper cassette sensor
- Lower paper cassette registration sensor
- High-voltage power supply

For the entire circuit diagram of the engine PCB, see [APPENDIX 11](#).

1.5 Control Panel PCB

The following parts are on the control panel PCB.

- Control panel: 12 buttons, FPC key (one set of 10 keys), 3 LEDs, 1 sixteen-segment LCD
- Document front sensor
- Document rear sensor
- Gate array MPD05611-PNL3

For the entire circuit diagram of the control panel PCB, see [APPENDIX 12](#).

1.6 Power Supply

1.6.1 Low-voltage power supply

The power supply uses a switching regulation system to generate the regulated DC power (+5V and +24V), which are converted from the AC line.

The regulated output and the production code of each power supply are listed below;

Regulated Output	Production Code
+5V / 1.6 A	100V: MPW1555
+24V / 2.15 A	200V: MPW1455

For the circuit diagram of the low-voltage power supply PCB, see [APPENDIX 13](#) or [14](#).

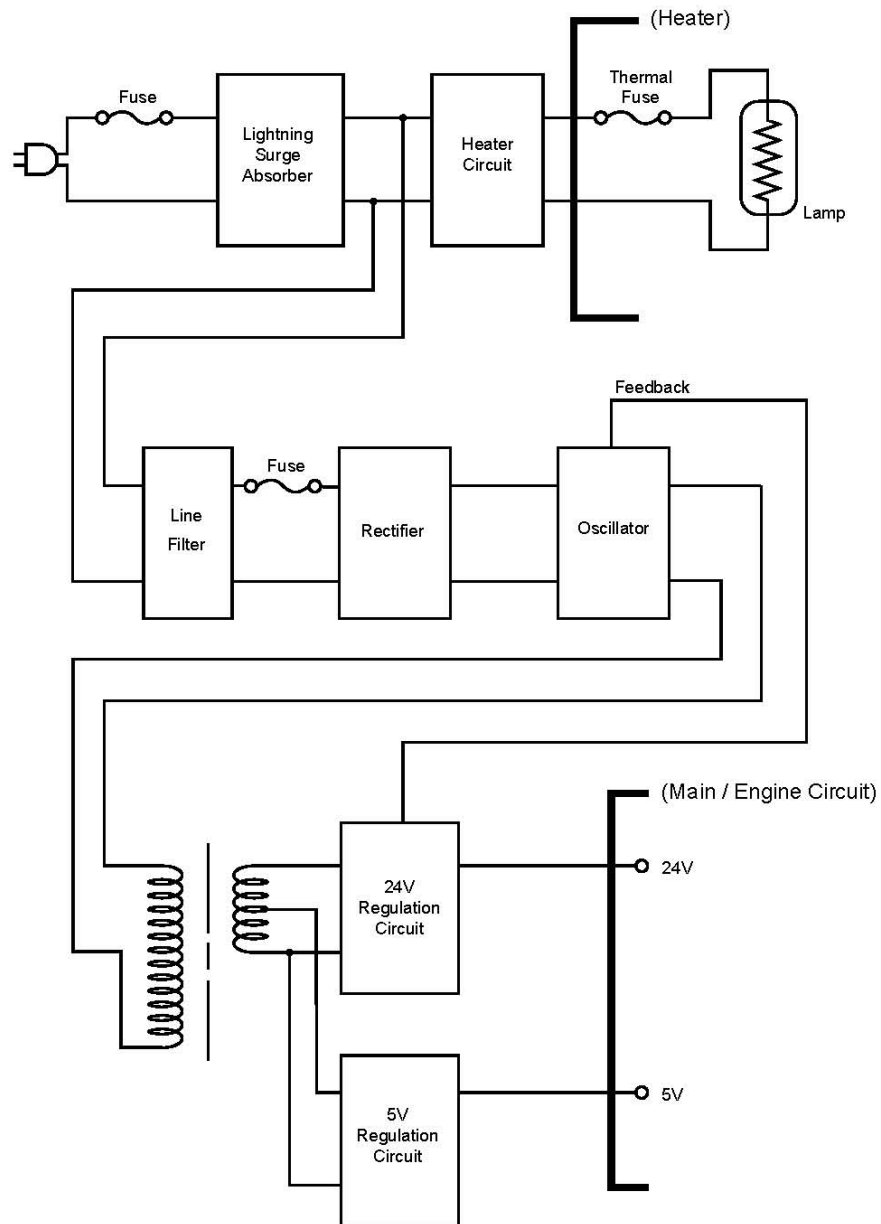

Fig. 3-12

1.6.2 High-voltage power supply

The high-voltage power supply generates and outputs the voltages and currents for the charging, development and transfer functions.

For the circuit diagram of the high-voltage power supply PCB, see [APPENDIX 15](#).

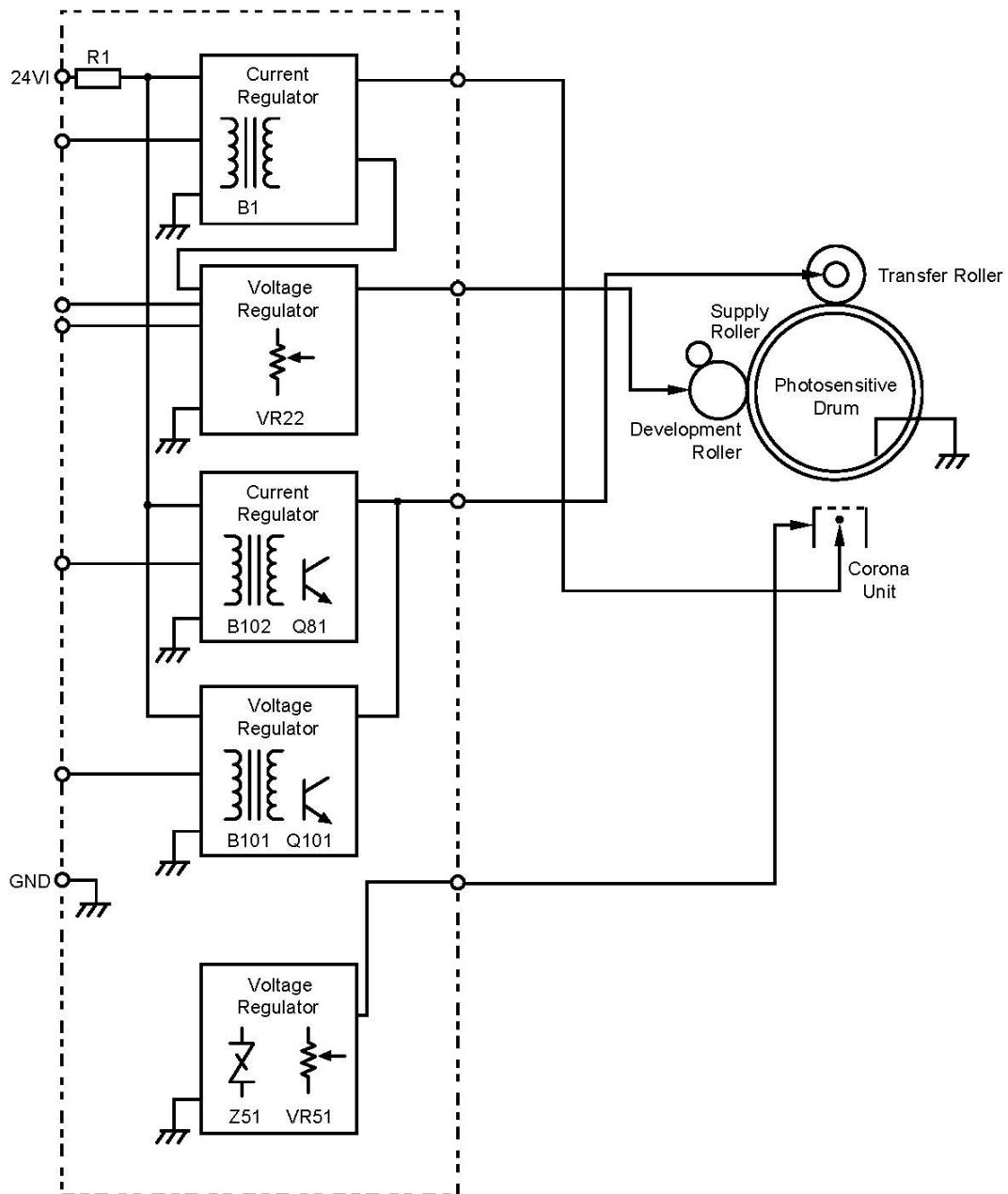

Fig. 3-13

2. MECHANICS

2.1 General Overview of Mechanism

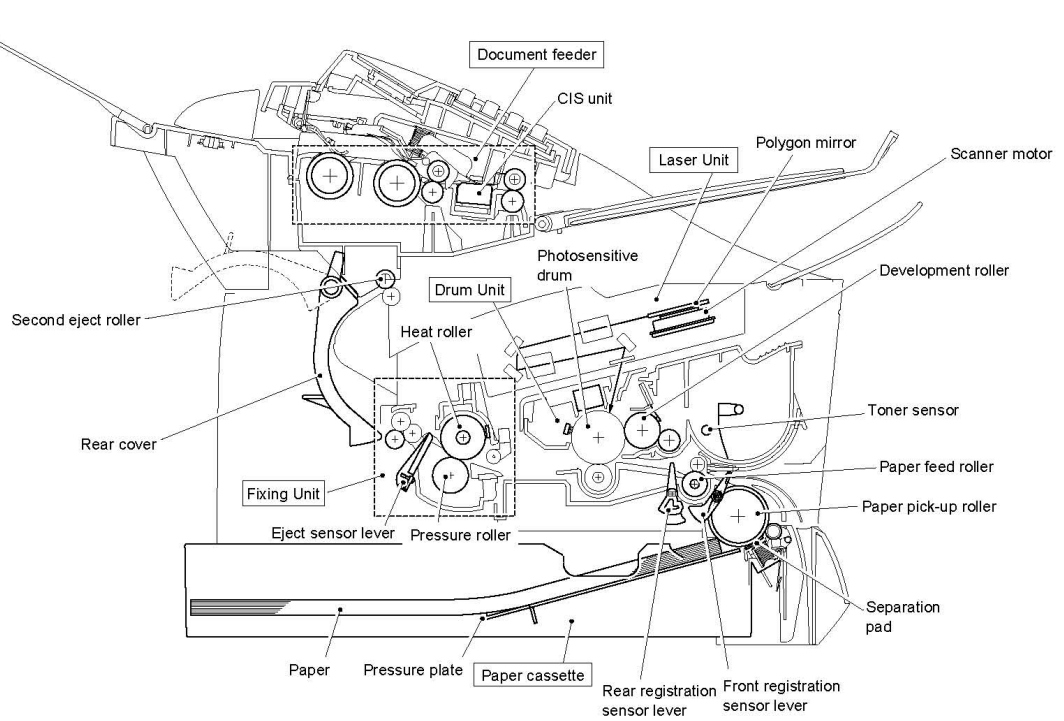

Fig. 3-14

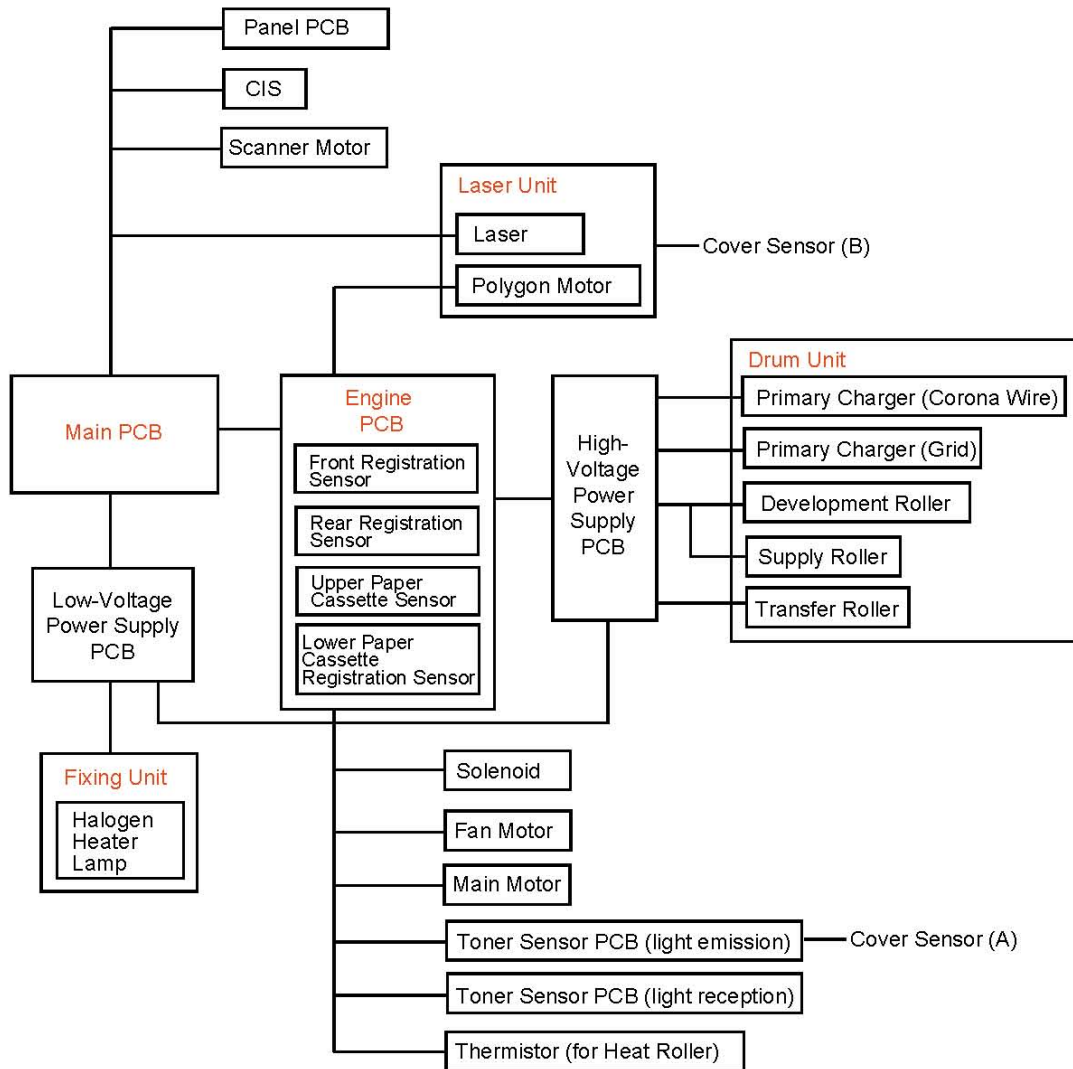

Fig. 3-15

2.2 Printer Mechanism

2.2.1 Paper transfer

(1) Paper supply

The pick-up roller picks up one sheet of paper from the paper cassette every time it is rotated and feeds it to the paper feed roller.

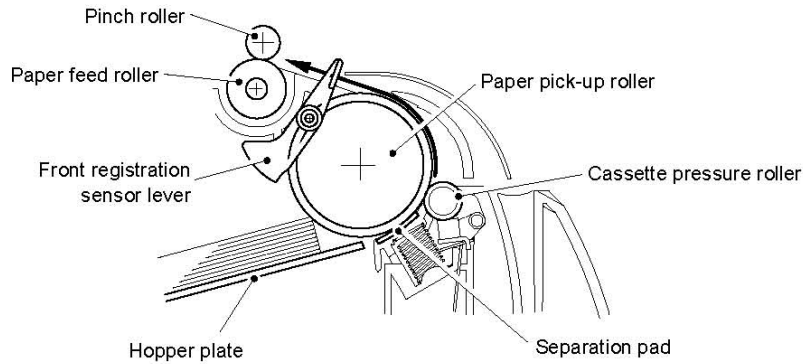

Fig. 3-16

The paper is gripped between the pick-up roller and the separation pad and separated into individual sheets.

The pick-up roller is directly connected to the clutch mechanism, whose rotation is stopped by the stopper. When the pick-up solenoid is activated, the clutch mechanism is engaged by the solenoid action and the paper pick-up roller is driven. The paper drawn out by the pick-up roller pushes against the front registration sensor lever and the paper top position/absence of paper is detected by sensing the motion of the lever.

(2) Registration

After the paper top position is detected by the front registration sensor, the paper, separated into individual sheets by the pick-up roller, is fed further in a specified time, and the paper top position reaches the paper feed roller so that the paper skew is adjusted. Then, the solenoid is turned off, the paper feed roller starts turning and the paper is fed to the transfer block in the process unit.

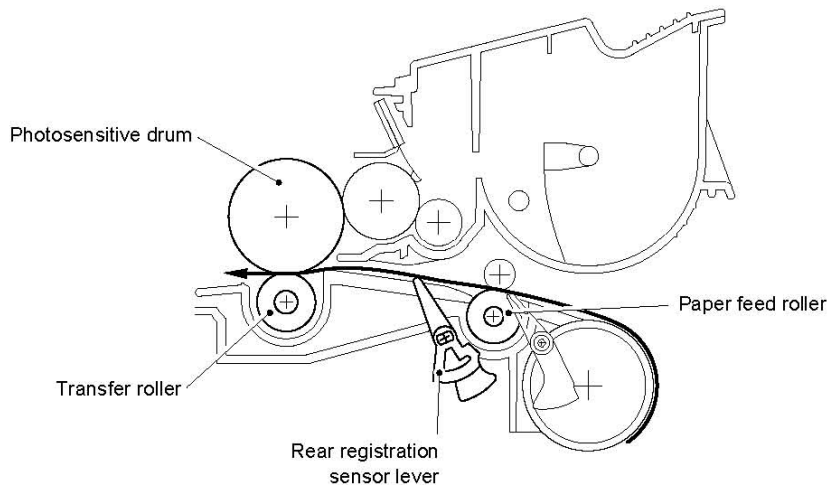

Fig. 3-17

The rear registration sensor in the path from the feed roller to the transfer roller adjusts the first printing position on the paper.

(3) Paper eject

After the printing image on the photosensitive drum is transferred onto the paper, the paper is fed to the fixing unit to fix unfixed toner onto the paper.

Afterwards, the paper is ejected from the fixing unit by the first eject roller in the fixing unit. The eject sensor lever also detects whether the paper is ejected correctly.

After the paper exits from the first eject roller, the paper is turned over along the rear cover and ejected to the output tray by the second eject roller.

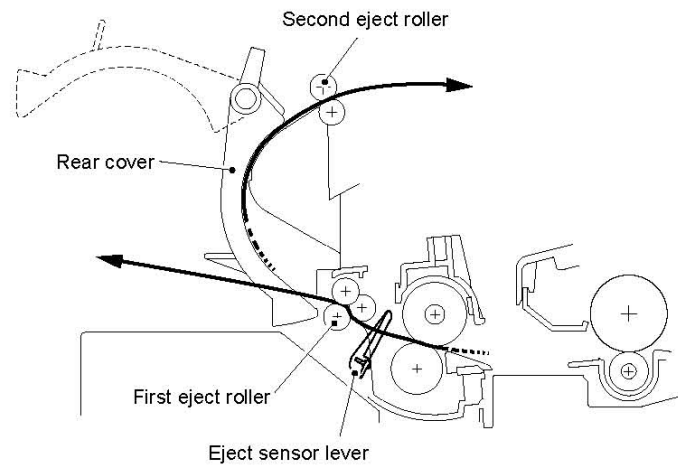

Fig. 3-18

2.2.2 Sensors

(1) Cover sensors A & B

Detect opening and closing of the front cover.

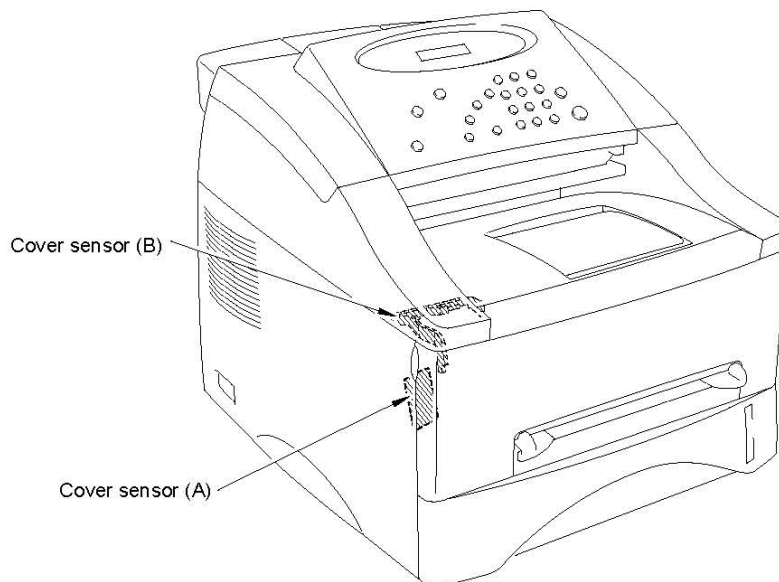

Fig. 3-19

(2) Toner sensor

Detects if there is toner in the toner cartridge. The toner sensor at the left side emits light through the window on the left side of the toner cartridge, then the toner sensor at the right side receives it. They also detect whether or not the drum unit is installed. (The toner cartridge is installed in the drum unit.)

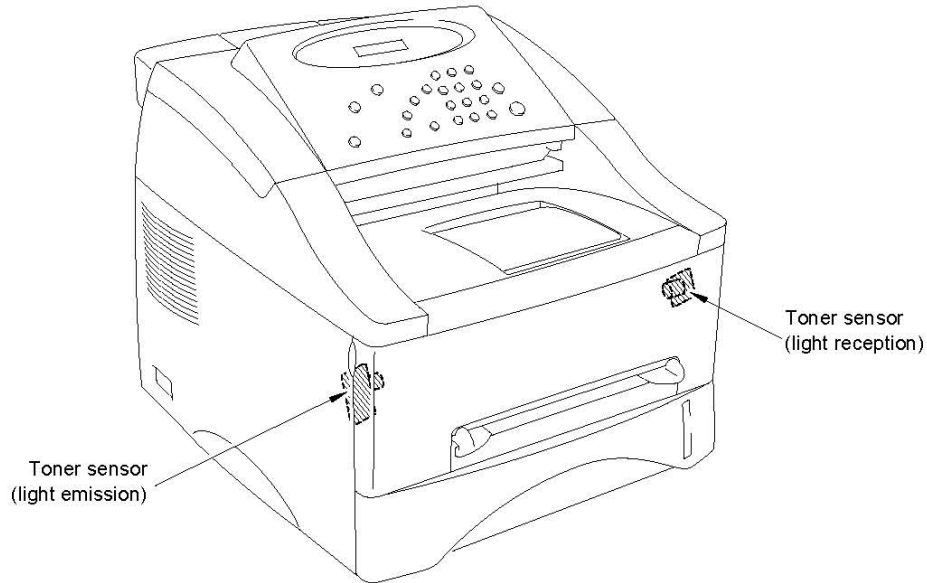

Fig. 3-20

2.2.3 Drum unit

(1) Photosensitive drum

Generates the latent electrostatic image and develops the image on the drum surface.

(2) Primary charger

Forms a uniform charge on the drum surface.

- i) Corona wire: Generates the ion charge on the drum.
- ii) Grid: Spreads the ion charge evenly over the drum surface.

(3) Transfer roller

Transfers the toner image to the paper from the drum surface.

(4) Cleaner

Removes the paper dust or dirt on the surface of the photosensitive drum.

2.2.4 Toner cartridge

Develops the electrostatic latent image on the photosensitive drum with toner and forms the visible image.

2.2.5 Print process

(1) Charging

The drum is charged to approximately 870V by an ion charge which is generated by the primary charger. The charge is generated by ionization of the corona wire, which has a DC bias from the high-voltage power supply applied to it. The flow of the ion charge is controlled by the grid to ensure it is distributed evenly on the drum surface. The aluminum drum sleeve in the photosensitive drum is grounded.

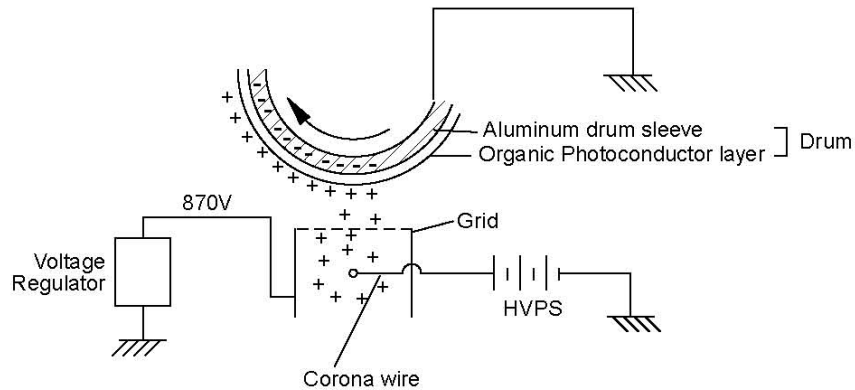

Fig. 3-21

The primary charge uses a corona wire, but since the drum is positively charged, only less than 1/10 of the usual quantity of ozone is generated compared with a negatively charged drum. The level of ozone expelled from the printer is therefore not harmful to the human body. Applicable safety standards have been complied with.

(2) Exposure stage

After the drum is positively charged, it is exposed to the light emitted from the laser unit.

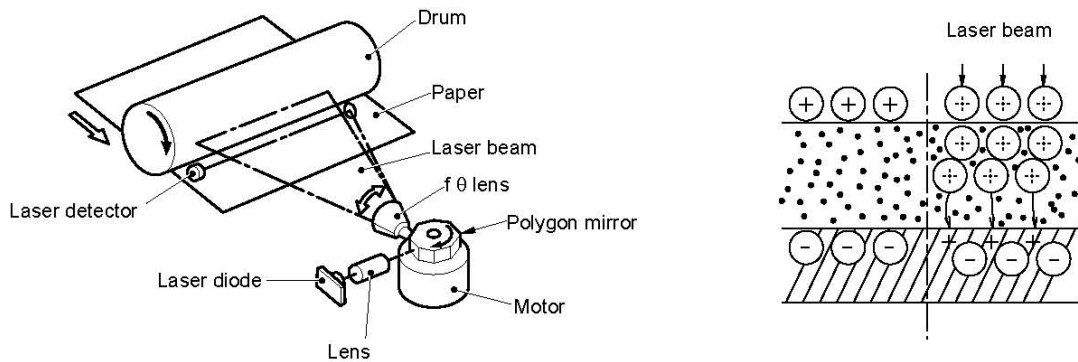

Fig. 3-22

The area exposed to the laser beam is the image to be printed. The surface potential of the exposed area is reduced, forming the electrostatic image to be printed.

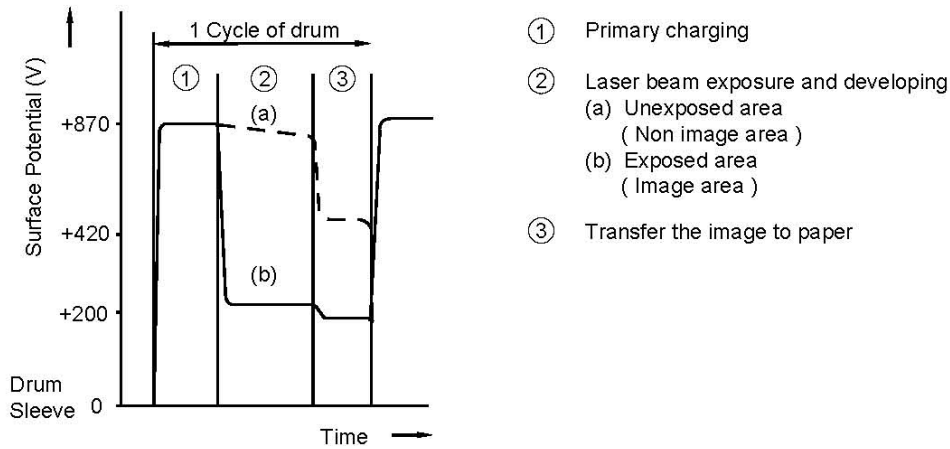

Fig. 3-23

(3) Developing

Developing causes the toner to be attracted to the electrostatic image on the drum so as to transform it into a visible image.

The developer consists of a non-magnetic toner. The development roller is made of conductive rubber and the supply roller (which is also made of conductive sponge) rotate against each other. The toner is charged and carried from the supply roller to the development roller. The toner adheres to the development roller and is conveyed to the drum at an even thickness controlled by the blade. The toner is nipped between the development roller and the drum and developed onto the latent image on the drum. The electrostatic field between the drum and the development roller, which is DC-biased from the high-voltage power supply, creates the electrostatic potential to attract toner particles from the development roller to the latent image area on the drum surface.

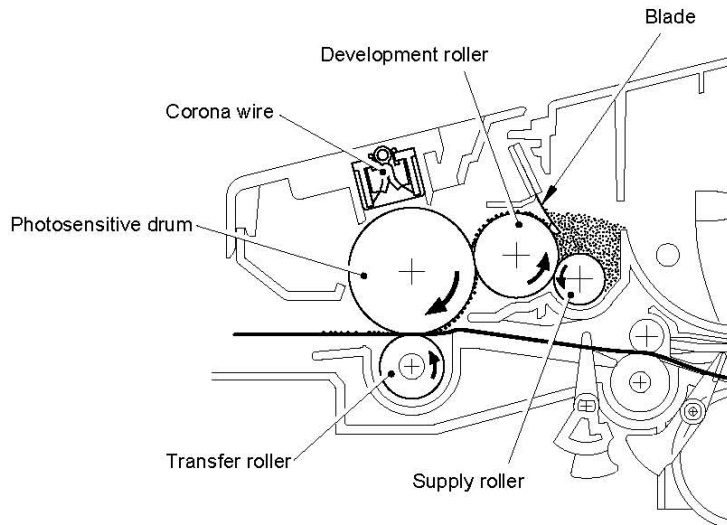

Fig. 3-24

(4) Transfer

i) Transfer process

After the drum has been charged and exposed, and has received a developed image, the toner image formed is transferred onto the paper by applying a negative charge to the back of the paper. The negative charge applied to the paper causes the positively charged toner to leave the drum and adhere to the paper. As a result, the image is visible on the paper.

ii) Cleaning process of transfer roller

If the toner is not transferred onto the paper perfectly it is possible that there may be residual toner on the drum which will adhere to the transfer roller. The transfer voltage changes to a positive voltage during non-printing rotation of the drum. Therefore the transfer roller is cleaned by returning the positively charged toner adhering to the transfer roller onto the photo-conductive drum.

(5) Fixing stage

The image transferred to the paper by static electricity is fixed by heat and pressure when passing through the heat roller and the pressure roller in the fixing unit. The thermistor keeps the surface temperature of the heat roller constant by detecting the surface temperature of the heat roller and turning on or off the halogen heater lamp.

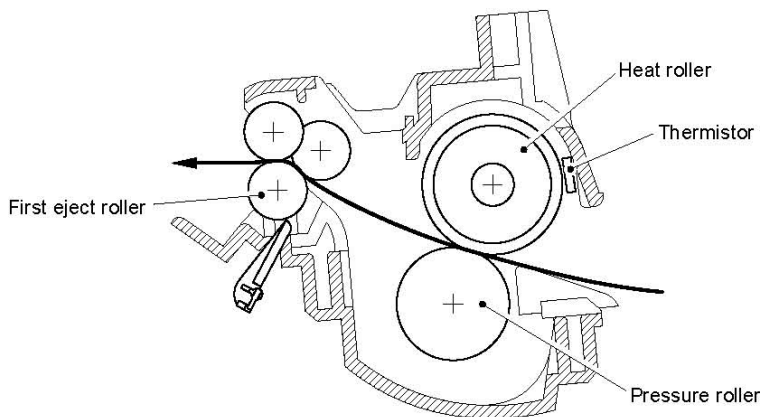

Fig. 3-25

2.3 Scanner Mechanism

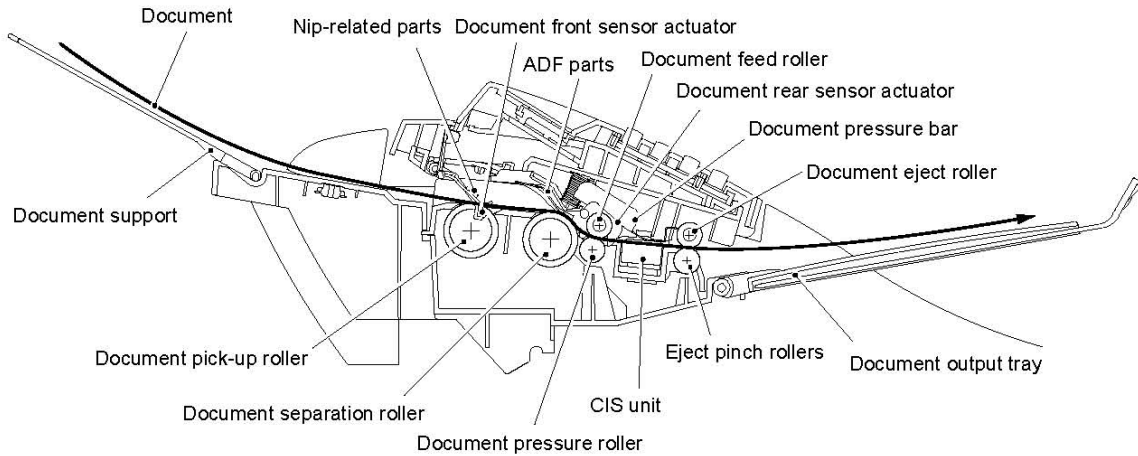

Fig. 3-26

2.3.1 Document transfer (feed and eject)

This mechanism consists of the document stacker, automatic document feeder (ADF), document eject roller ASSY and two document sensors (document front sensor, document rear sensor).

If documents are set face down on the document stacker to start the scanning operation, the document front sensor detects the document, then the scanner motor rotates so that the ADF (which consists of the document pick-up roller, nip-related parts, separation roller and ADF parts) feeds those documents into the printer, starting from the bottom sheet to the top, page by page. Each document is advanced by the document feed roller ASSY to the scanner, and it is fed out of the scanner by the document eject roller ASSY. The document rear sensor detects that the document is fed out without any paper jam.

2.3.2 Scanner

The scanner uses a contact image sensor (CIS) unit which consists of an LED array to illuminate the document, a self-focus lens array to collect the reflected light, a CIS PCB to carry out photoelectric conversion to output picture element data and a cover glass on which the document advances. When the document passes between the document pressure bar and the cover glass, it is scanned.

CHAPTER 4 DISASSEMBLY AND RE-ASSEMBLY

1. SAFETY PRECAUTIONS

To avoid creating secondary problems by mishandling, follow the warnings and precautions below during maintenance work.

WARNING

- (1) Always turn off the power switch and unplug the power cord from the power outlet before accessing any parts inside the printer.
- (2) Some parts inside the printer are extremely hot immediately after the printer is used. When opening the front cover or rear cover to access any parts inside the printer, never touch the red colored parts shown in the following figures.

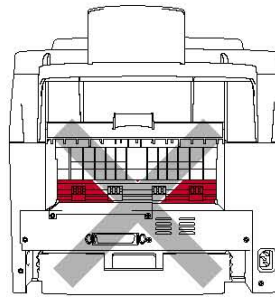
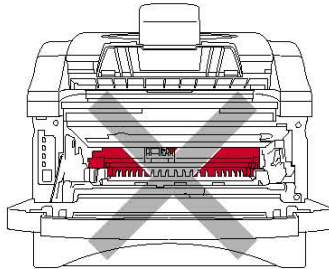

CAUTION:

- (1) Be careful not to lose screws, washers, or other parts removed during servicing.
- (2) Be sure to apply grease to the gears and applicable positions specified in this chapter.
- (3) When using soldering irons or other heat-generating tools, take care not to accidentally damage parts such as wires, PCBs and covers.
- (4) Before handling any PCBs, touch a metal portion of the equipment to discharge any static electricity charge on your body, or the electronic parts or components may be damaged.
- (5) When transporting PCBs, be sure to wrap them in the correct protective packaging.
- (6) Be sure to replace self-tapping screws correctly, if removed. Unless otherwise specified, tighten screws to the following torque values.

TAPTITE, BIND or CUP B

M3: 70N • cm

M4: 80N • cm

TAPTITE, CUP S

M3: 80N • cm

SCREW

M3: 70N • cm

M4: 80N • cm

- (7) When connecting or disconnecting cable connectors, hold the connector body, not the cables. If the connector has a lock, release the connector lock first to release it.
- (8) After a repair, check not only the repaired portion but also all connectors. Also check that other related portions are functioning properly before operational checks.

2. DISASSEMBLY FLOW

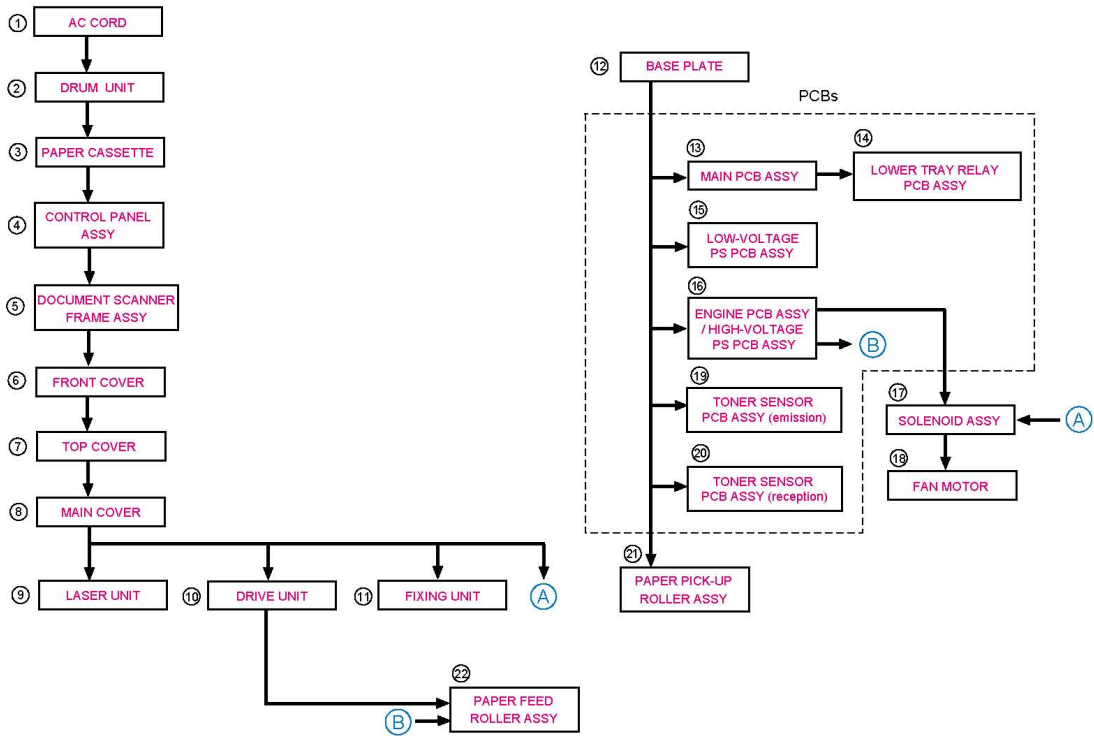

3. DISASSEMBLY PROCEDURE

3.1 AC Cord

- (1) Disconnect the AC cord from the printer AC inlet.

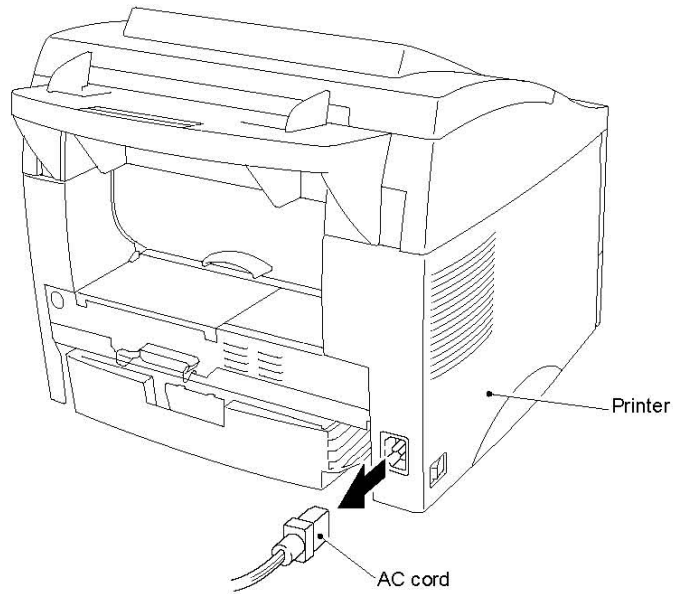

Fig. 4-1

3.2 Drum Unit

- (1) Open the front cover and remove the drum unit from the printer.

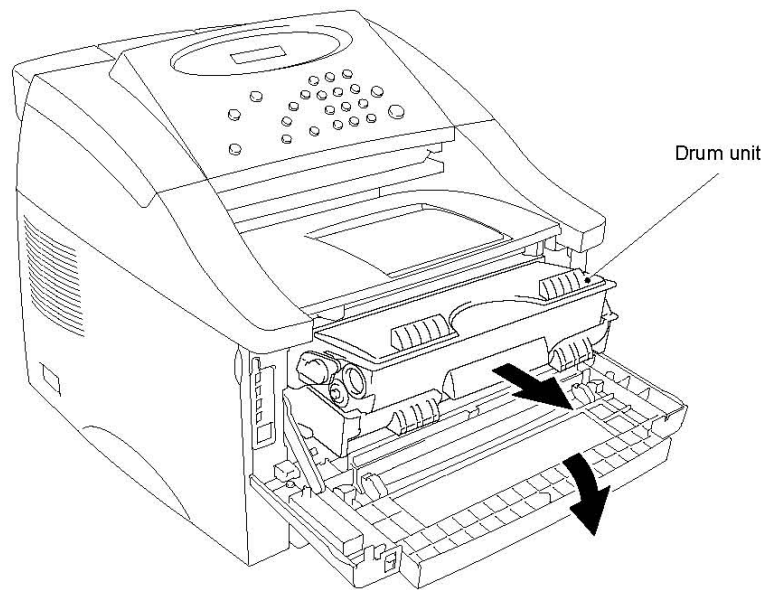

Fig. 4-2

3.3 Paper Cassette

- (1) Close the front cover, pull out the paper cassette from the printer and remove the paper from the cassette.

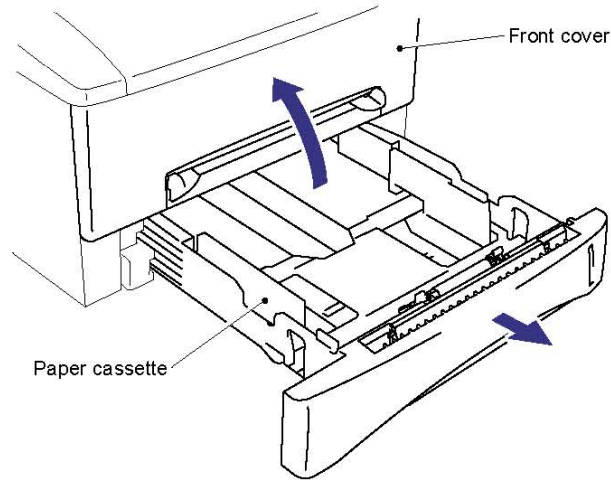

Fig. 4-3

- (2) Remove the separation pad holder ASSY by pulling it upwards, then remove the separation pad spring from the paper cassette.

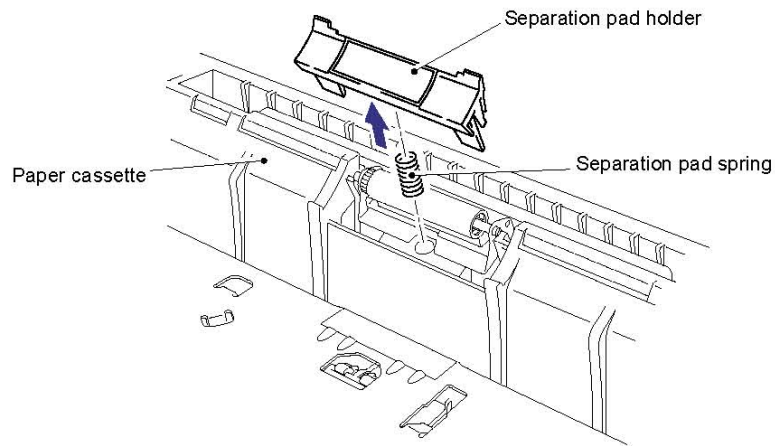

Fig. 4-4

- (3) Turn the paper cassette upside down, then remove the cassette cover film by peeling it carefully from the underside of the cassette.
- (4) Remove the M3x8 Taptite screw and remove the paper cassette cover from the front of the cassette.

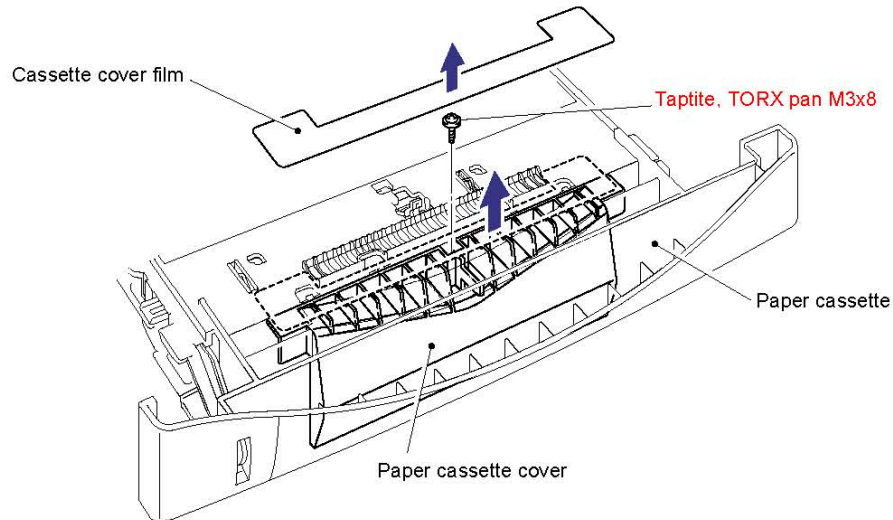

Fig. 4-5

NOTE:

- *The cover film must not be reused after it has been removed. Always replace it with a new one.*
- *The screw securing the paper cassette cover indicated RED in the figure above is very special. When disassembling/re-assembling the screw, you need a special screw driver. Refer to the parts reference list.*

- (5) Keeping the paper cassette upside down, release the pressure roller holder assembly from the cassette by releasing the metal mounting plate from the plastic retaining boss. Use a flat screwdriver to press the metal plate forwards until it clears the boss and then remove the pressure roller holder assembly downwards from the cassette.
- (6) Remove the cassette pressure roller from the assembly, then remove the pressure roller shaft from the pressure roller.
- (7) Remove the sponge holder ASSY from the holder. The two sponge holder springs will also come off.

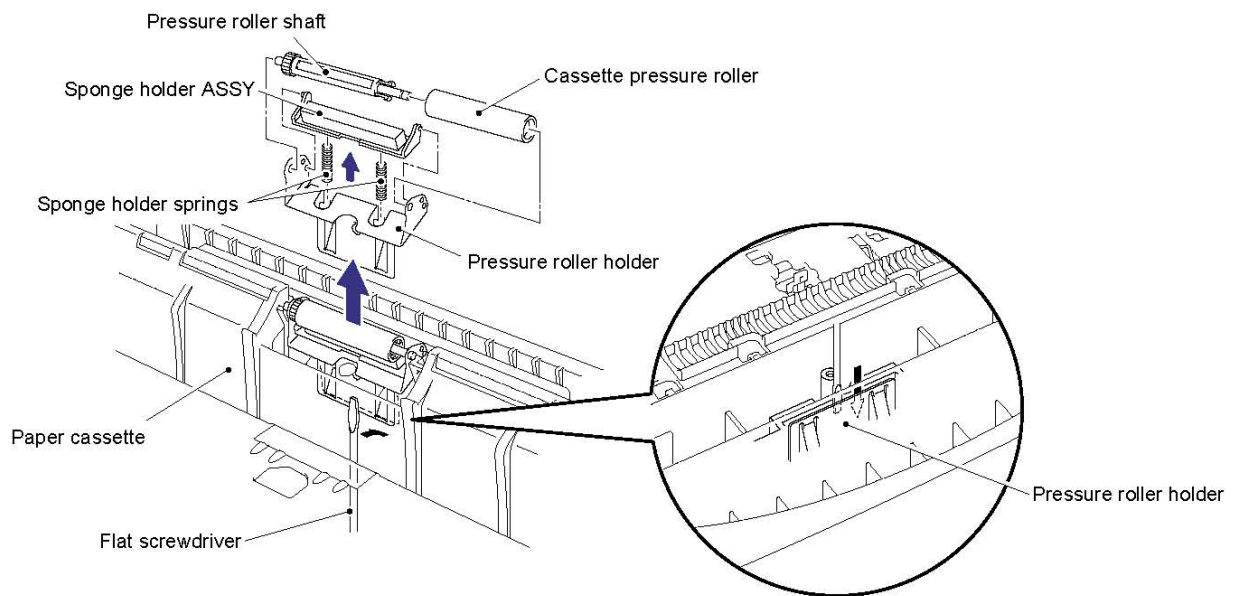

Fig. 4-6

- (8) Keeping the paper cassette upside down, remove the two M2.6x5 Taptite screws.
- (9) Unhook the catches of each side guide, then press the lock lever towards the front of the cassette to release the pressure plate.

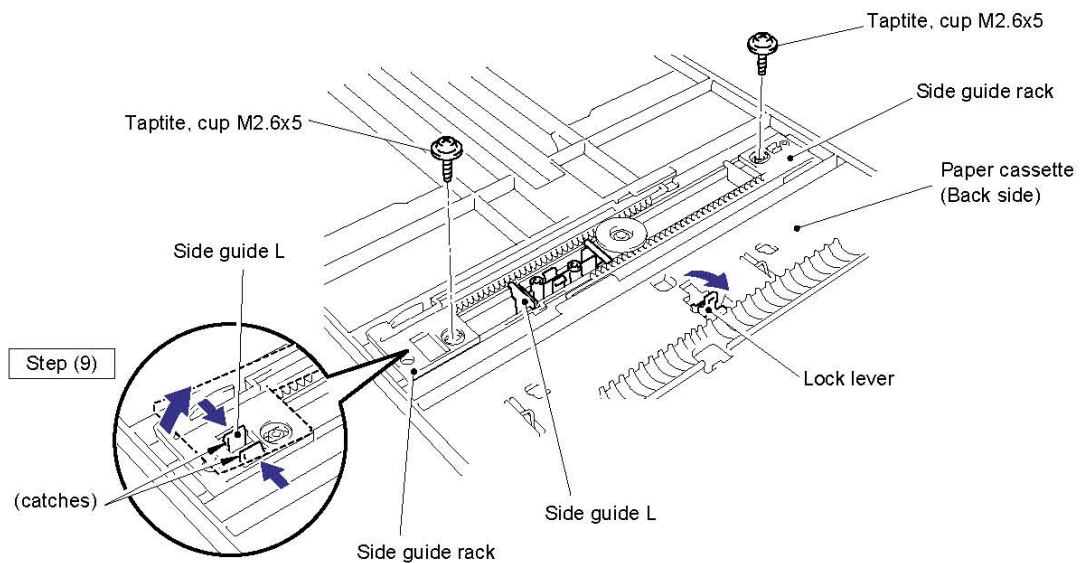

Fig. 4-7

- (10) Turn the cassette the correct way up and slide the two paper guides to the center of the cassette.
- (11) Remove the side guides Left and Right from the paper cassette.

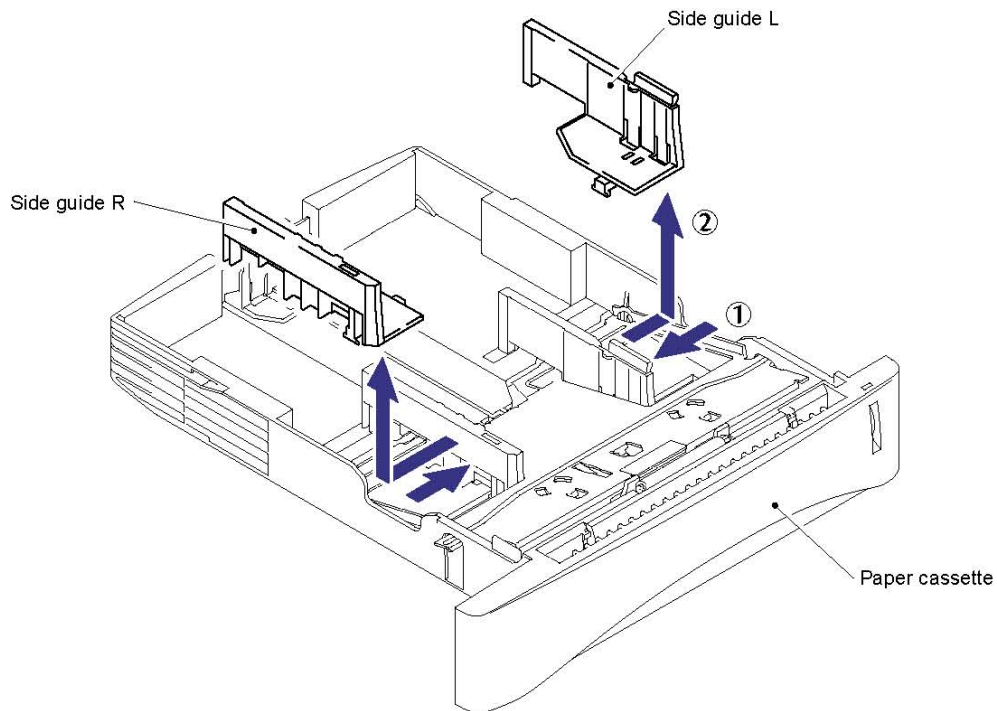

Fig. 4-8

- (12) Unhook the two catches (A) of the pressure plate while pulling the plastic frame outwards, then unhook the other two catches (B) of the plate while pulling the plastic frame outwards to remove the pressure plate ASSY.
- (13) Unhook the pressure plate spring from the plastic hook to remove the two pressure plate springs.

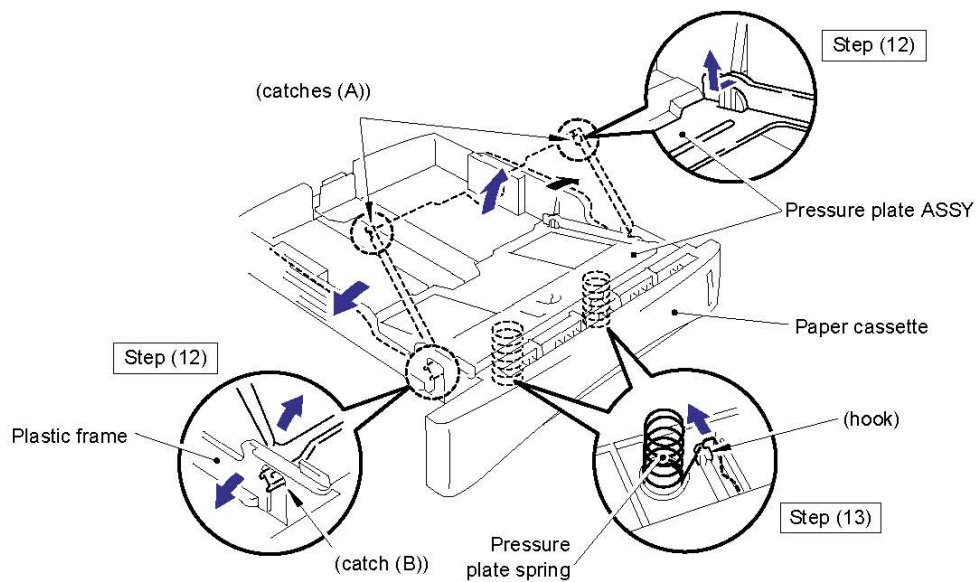

Fig. 4-9

NOTE:

When re-assembling the pressure plate ASSY, ensure that the paper indicator arm is under the pressure plate.

CAUTION:

When unhooking the catches to remove the pressure plate, do not bend the pressure plate, gently ease the plastic cover. If the pressure plate is deformed, paper feeding problems may occur.

(14) Remove the release lever extension spring.

(15) Unhook the two catches and rotate the lock lever to remove it downwards from the cassette.

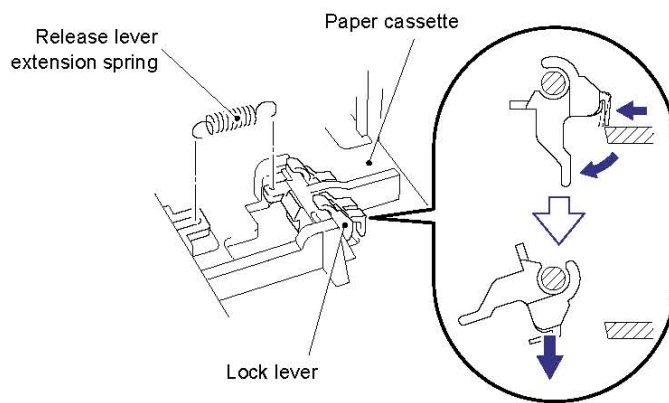

Fig. 4-10

NOTE:

When re-assembling the lock lever, insert it upwards from underneath the cassette and rotate it until the two catches lock into place..

(16) Slide the rear paper guide fully forwards in the cassette and remove it from the slot.

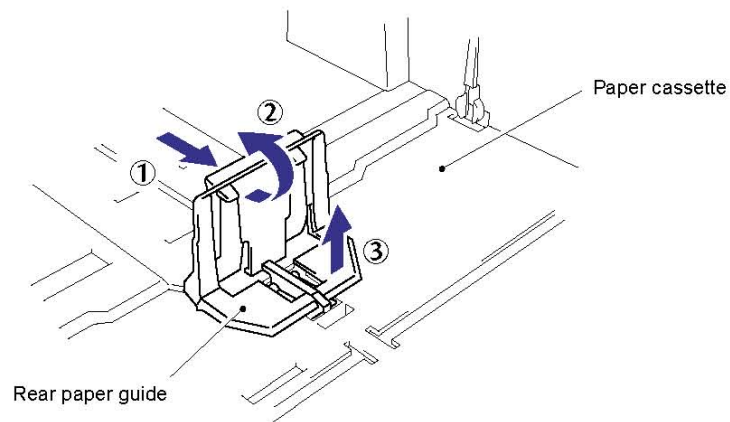

Fig. 4-11

- (17) Turn the cassette upside down and remove the one M3x8 Taptite screw to remove the side guide gear. Then remove the one friction spring.
- (18) Remove the two side guide racks.
- (19) Remove the paper indicator.

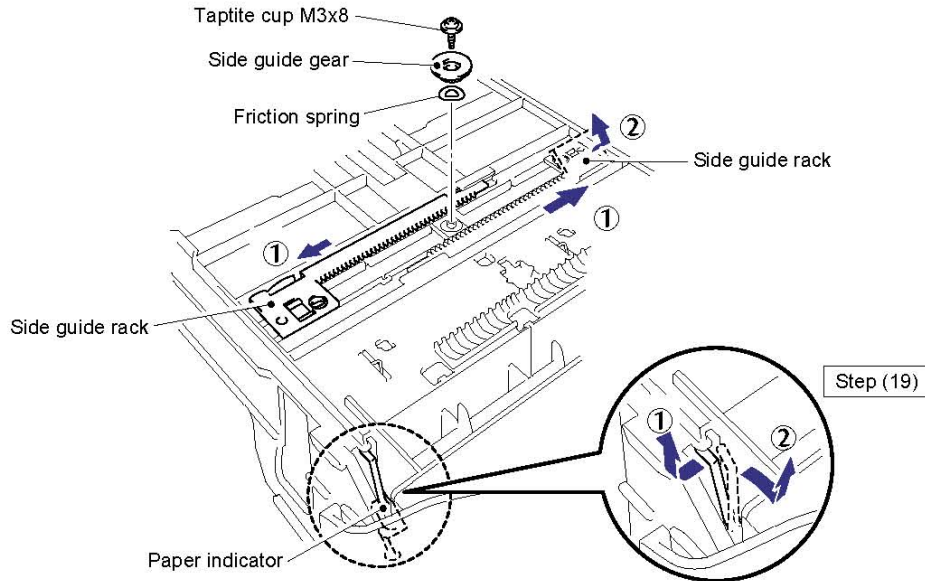

Fig. 4-12

NOTE:

When re-assembling the side guide racks, they should both be aligned so that the wide end of the racks are in line with the inside edge of the paper guide release slots in the cassette before refitting the spring and gear.

3.4 Control Panel ASSY

- (1) Slightly open the control panel ASSY toward you.
- (2) Push the hinges at the left and right sides of the control panel ASSY outwards (①), then open the control panel ASSY further (②) while sliding the control panel ASSY toward you to release the two hooks of the control panel ASSY (③).
- (3) Disconnect the panel harness on the right hand side.
- (4) Remove the control panel ASSY from the scanner frame.

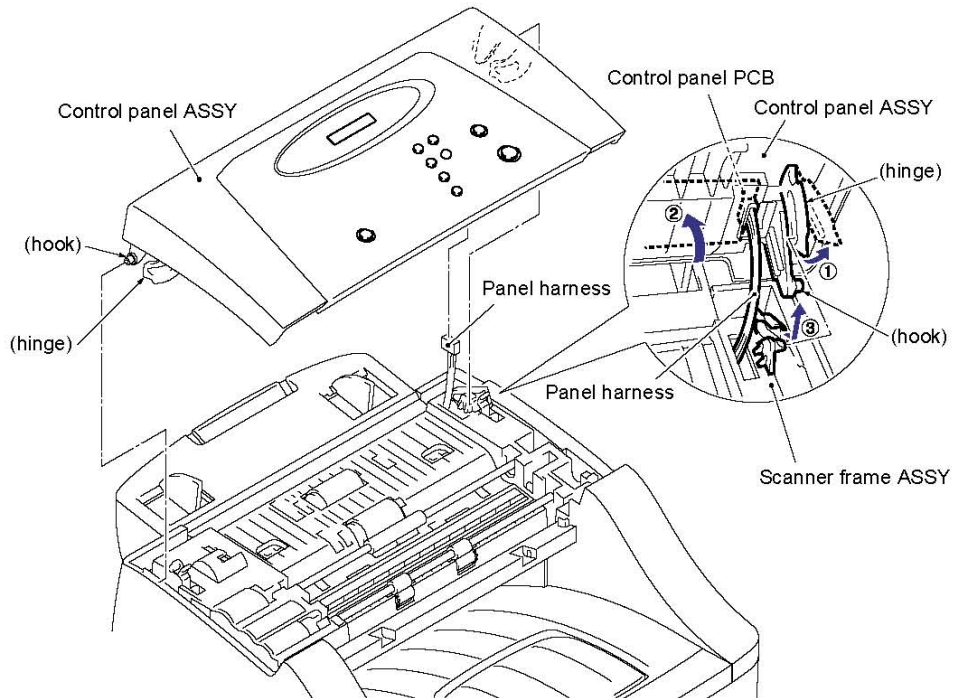

Fig. 4-13

- (5) Place the control panel ASSY upside down.
- (6) Remove the M3x6 Taprite screw to remove the front spring plate, separation rubber, rubber holder and ADF spring.
- (7) Push down the document nip piece (①), then press either side of the piece inwards to remove the nip piece and nip piece spring (②).

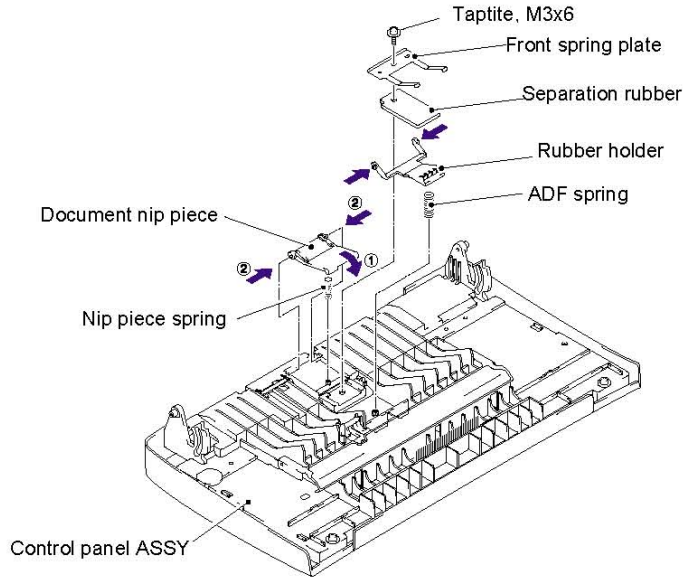

Fig. 4-14

- (8) Press support (A) on the panel rear cover inwards, then lift the document pressure bar up and towards the rear to release the three tabs from the panel rear cover. The spring also comes off.
- (9) Pull the support (B) on the panel rear cover outwards to remove the document rear sensor actuator.
- (10) Peel off the anti-static brush to replace it.

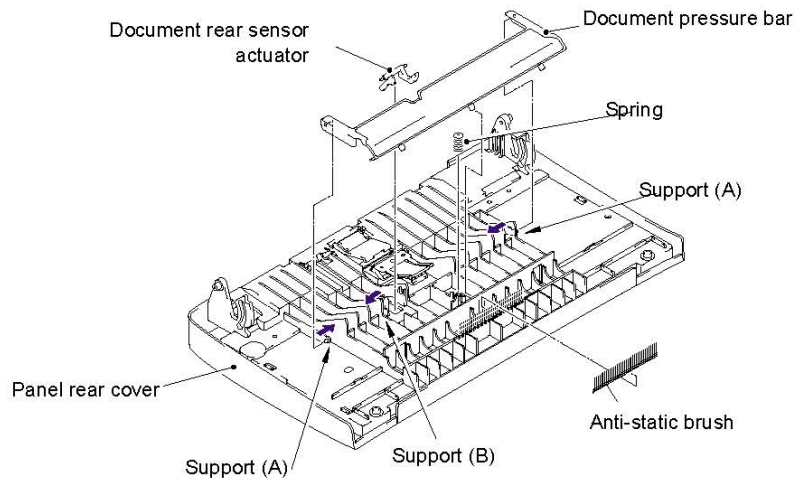

Fig. 4-15

CAUTION:

When disassembling/re-assembling the document pressure bar, ensure not to get stain on the bar. Failure to do so may cause poor scanning quality.

- (11) Remove the one M3x8 and two M3x10 Taptite screws to remove the panel rear cover.
- (12) Fully turn the document front sensor actuator to the rear and take it out.
- (13) Remove the M3x10 Taptite screw securing the control panel PCB ASSY.
- (14) Disconnect the two connectors connected to the control panel PCB ASSY to remove it.

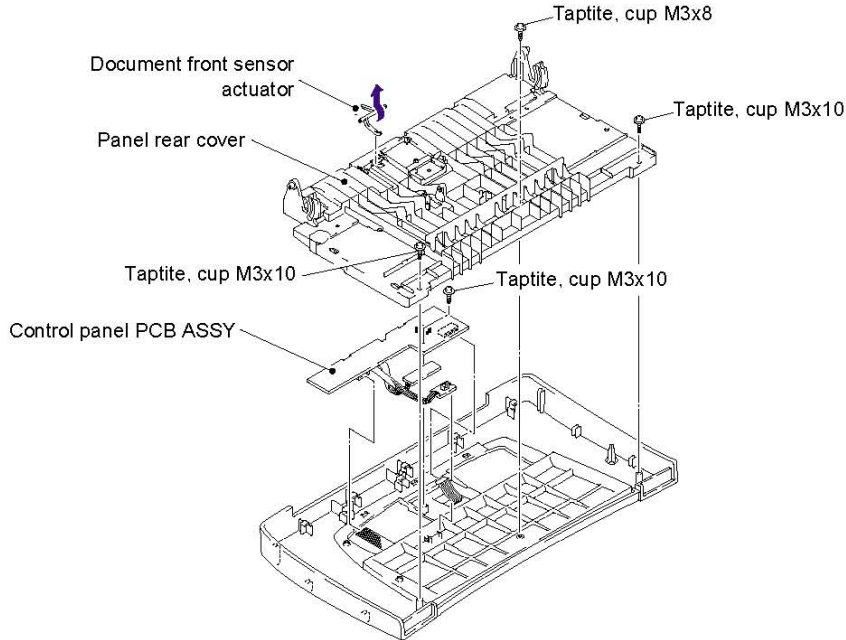

Fig. 4-16

- (15) Remove the three M3x10 Taptite screws to remove the panel cover from the document chute cover.
- (16) Remove the FPC key and LCD cover from the panel cover.

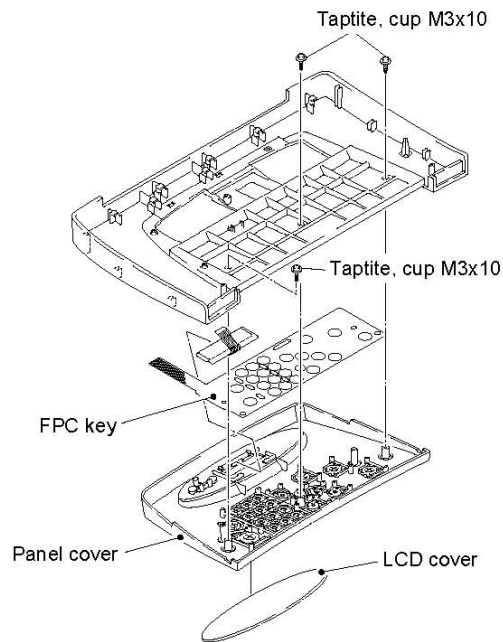

Fig. 4-17

- (16) Remove all the function keys (five 6mm keys, four 9.5mm keys, one set of 10-keys and one start key) from the panel cover.

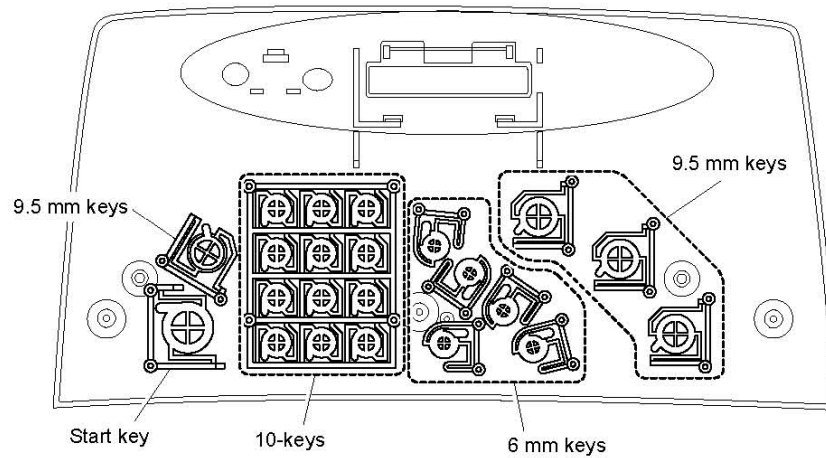

Fig. 4-18

- (17) Slightly pull the clamps backwards to remove the LCD while pulling the LCD flat cable gently.

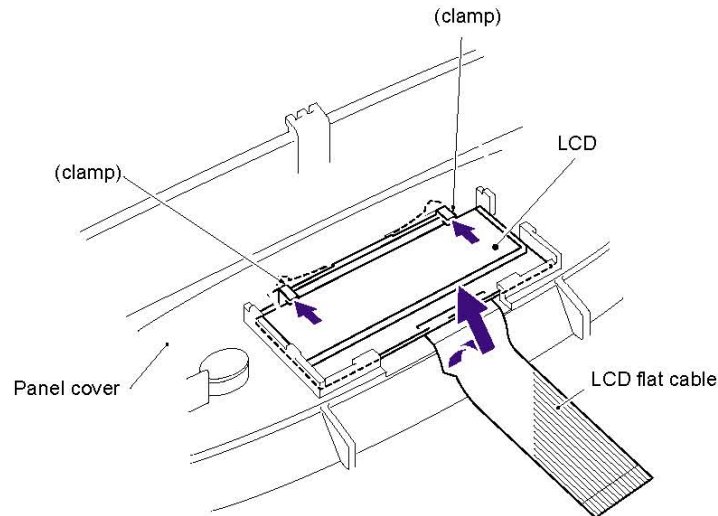

Fig. 4-19

NOTE:

- Before installing the LCD onto the control panel, wipe fingerprints or dust off the LCD surface and control panel window with a soft cloth.
- A new LCD is covered with a protection sheet. Before installing it, remove the protection sheet.

3.5 Document Scanner Frame ASSY

- (1) Lightly push arm rib (A) to the rear, then pull the document feed roller ASSY to the left and upwards.
- (2) Lightly push arm rib (B) to the rear, then pull the document eject roller ASSY to the left and upwards.

CAUTION:

Take care not to break the arm ribs. They may break easily.

- (3) Pull up the document eject pinch rollers and their shafts (springs).

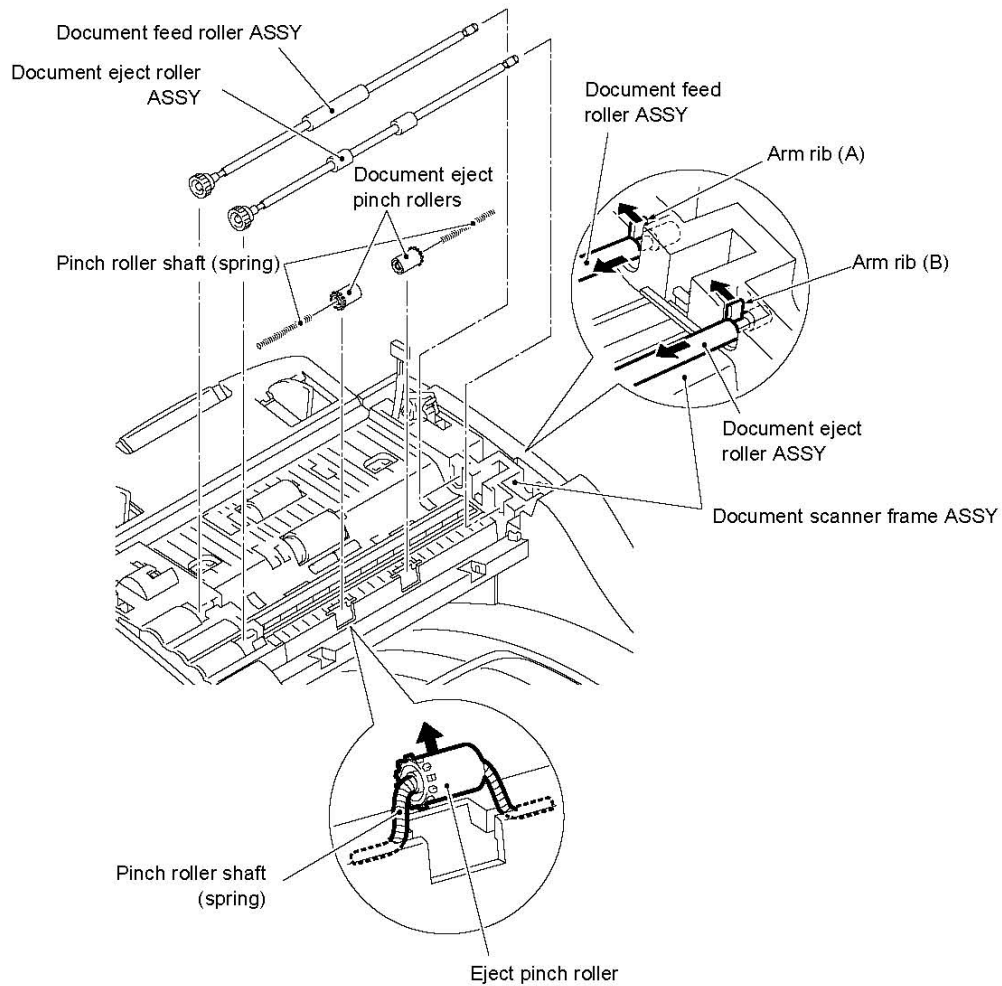

Fig. 4-20

- (4) Remove the four M3x10 Taptite screws securing the scanner frame.
- (5) Lift up the front edge of the scanner frame ASSY and pull the frame towards you to release the three tabs on the rear end from the top cover.

CAUTION:

Do not lift up the scanner frame ASSY more than 30mm to prevent the CIS harness connector on the CIS unit from getting damaged.

- (6) Hold up the scanner frame ASSY and disconnect the scanner motor harness and the CIS harness.

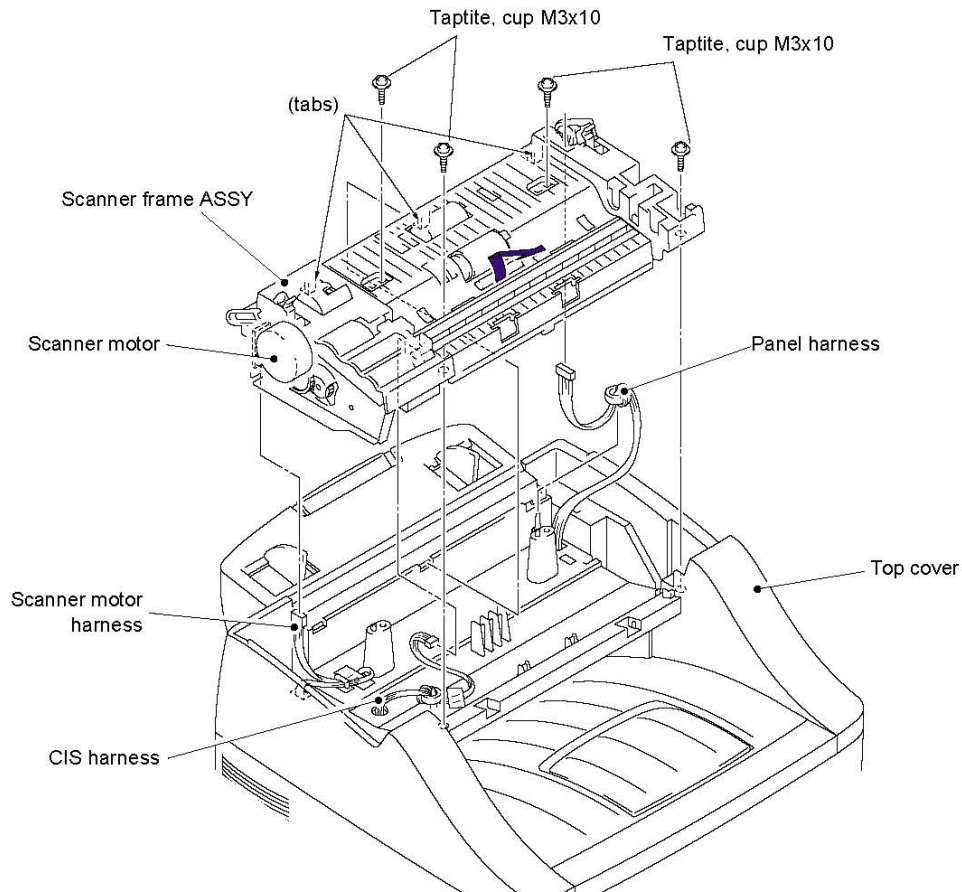

Fig. 4-21

CAUTION:

When re-assembling the scanner frame ASSY, first connect the CIS connector, then connect the scanner motor connector. Failure to do so may cause printer damage.

NOTE:

When connecting the CIS harness, refer to the figure below for correct cable routing and connection;

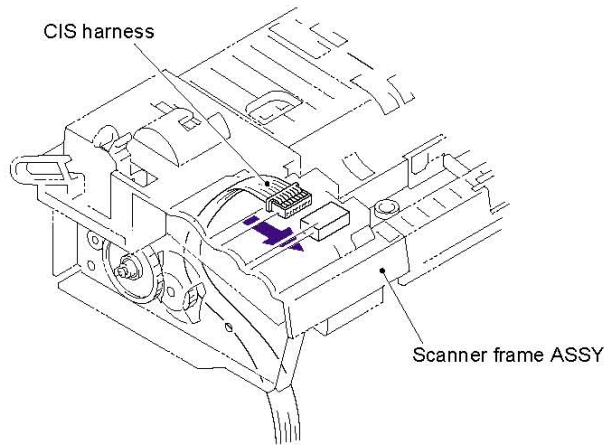

Fig. 4-22

- (7) Lightly pull up the arm (①), move the CIS unit to the right (②), then lift up the left edge of the unit gently (③).
- (8) The CIS springs will also come off.

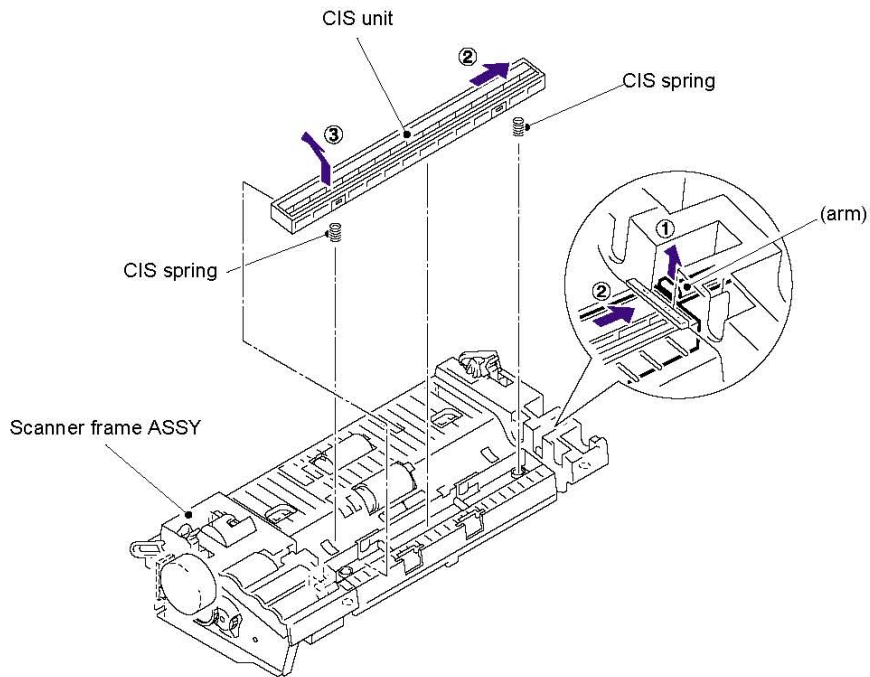

Fig. 4-23

- (9) Turn the scanner frame ASSY upside down.
- (10) Remove the M3x6 screw securing the scanner motor.
- (11) Turn the scanner motor as shown below to release it from the latch.

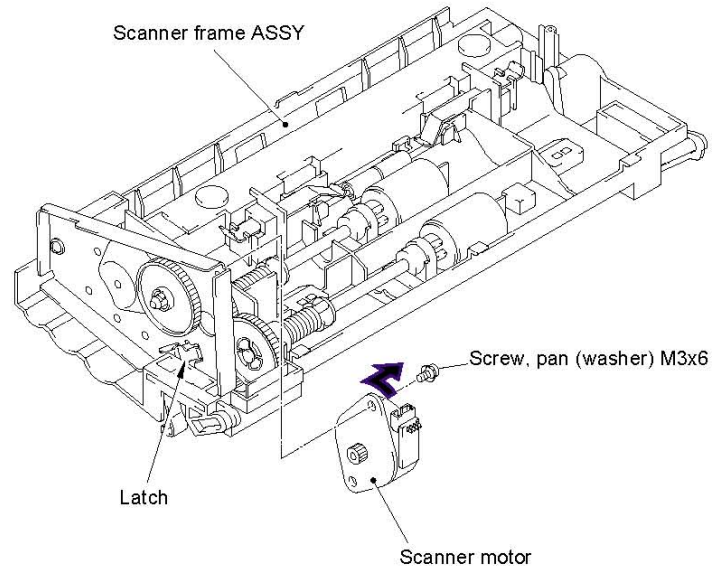

Fig. 4-24

- (12) Remove the two M3x8 Taptite screws to remove the scanner drive unit.

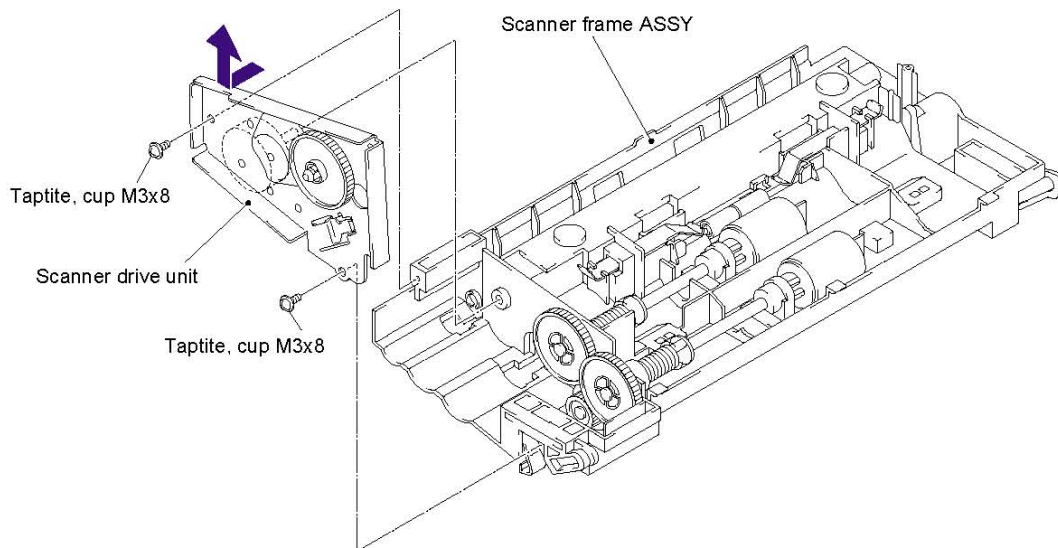

Fig. 4-25

- (13) Remove the document pick-up roller gear (①) by pulling its pawls outwards. Slightly push down on the arm (②) and move the document pick-up roller shaft to the left (③) to remove it. Then move the document pick-up roller to the left to remove it.
- (14) Remove the separation roller gear (①) by pulling its pawls outwards. Slightly push down on the arm (②) and move the document separation roller shaft to the left (③) to remove it. Then move the document separation roller to the left to remove it.

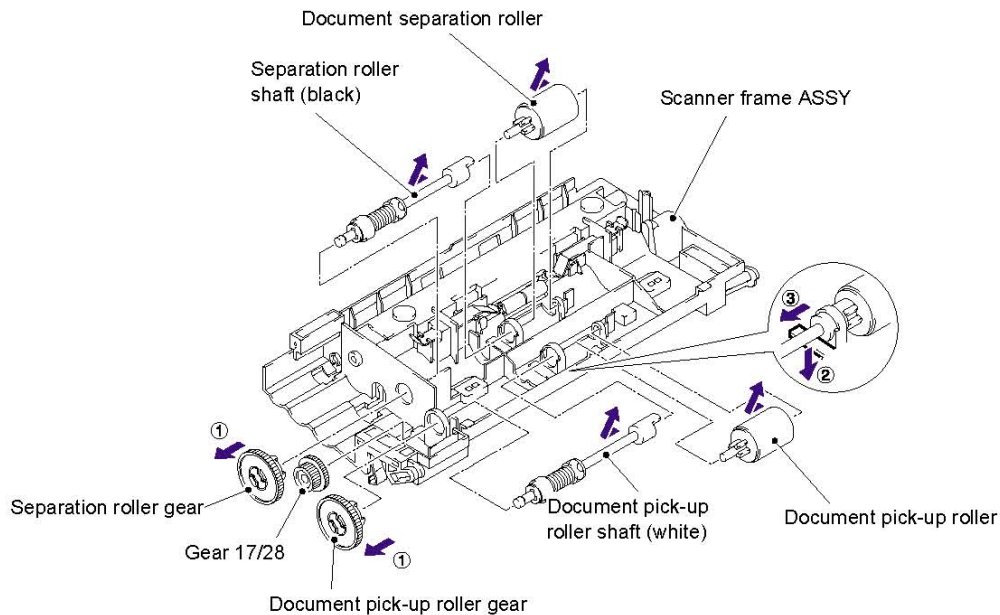

Fig. 4-26

- (15) Remove the two pressure roller leaf springs by pulling them in the direction as shown below. Then remove the document pressure rollers and shaft.

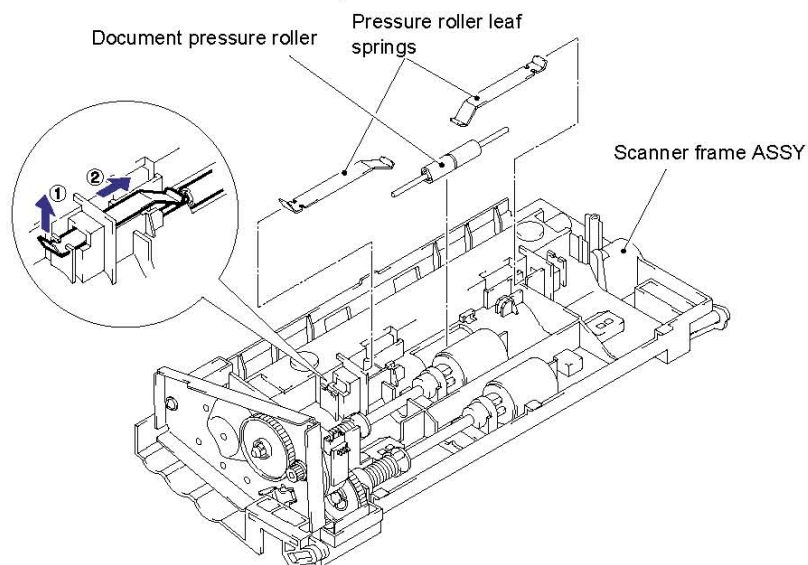

Fig. 4-27

NOTE:

- The document pick-up roller and separation roller are compatible with each other. Their gears are also compatible with each other. However, their shafts are not compatible. The document pick-up roller shaft should be a white one; the separation roller shaft should be a black one. When assembling these shafts to their rollers, fit the groove provided in each shaft over the longer boss on each roller.

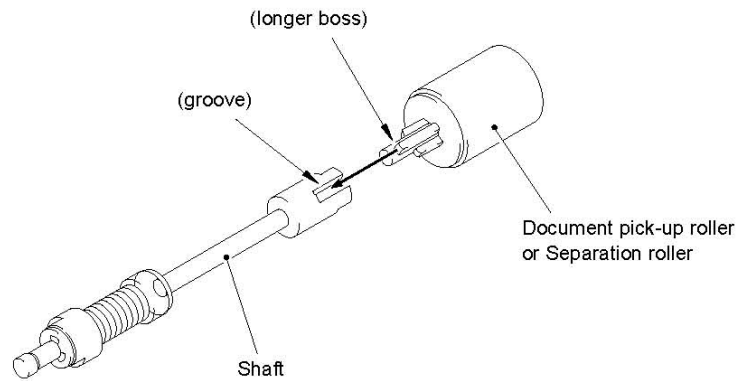

Fig. 4-28

- When re-assembling the scanner motor, fit it into the latch on the scanner frame with the connector facing upwards and then secure it with the screw.

3.6 Front Cover

- (1) Open the front cover.
- (2) Remove the four M3x8 Taptite screws from the main cover.

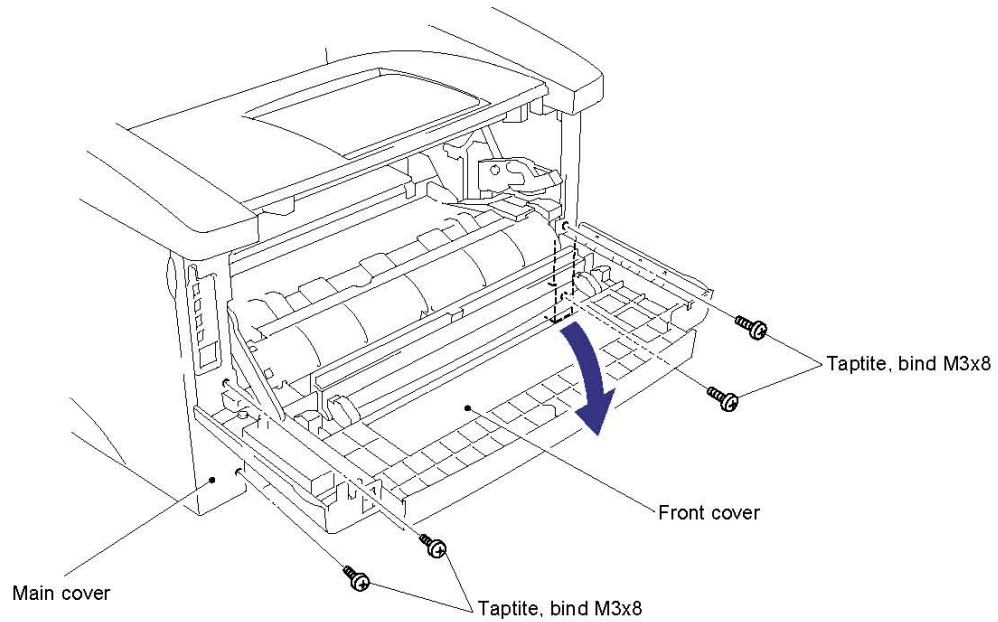

Fig. 4-29

- (3) Position the front cover at the angle of 45 degrees and release the bosses at the right and left hand sides and the link at the left hand side.
- (4) Remove the front cover.

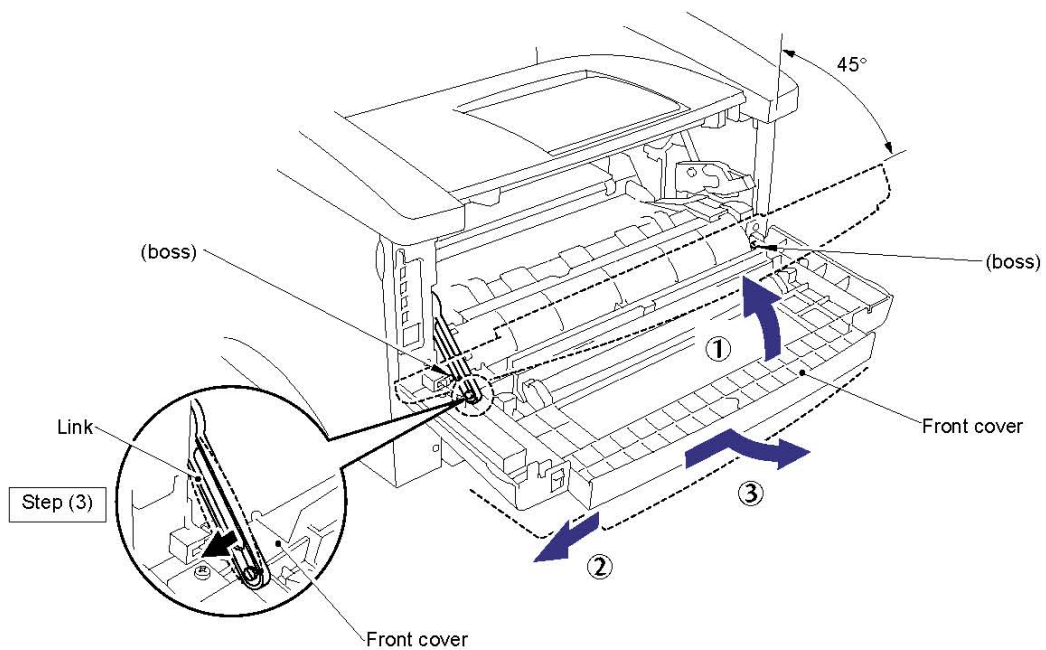

Fig. 4-30

3.7 Top Cover

- (1) Remove the four M3x10 Taptite screws securing the top cover.
- (2) Remove the ferrite core from both the panel harness and the CIS harness.
- (3) Release the hooks on either side of the top cover from the bosses on the main cover by pulling the top cover forwards.
- (4) Remove the M3x10 Taptite screw to remove the scanning ground plate if necessary.

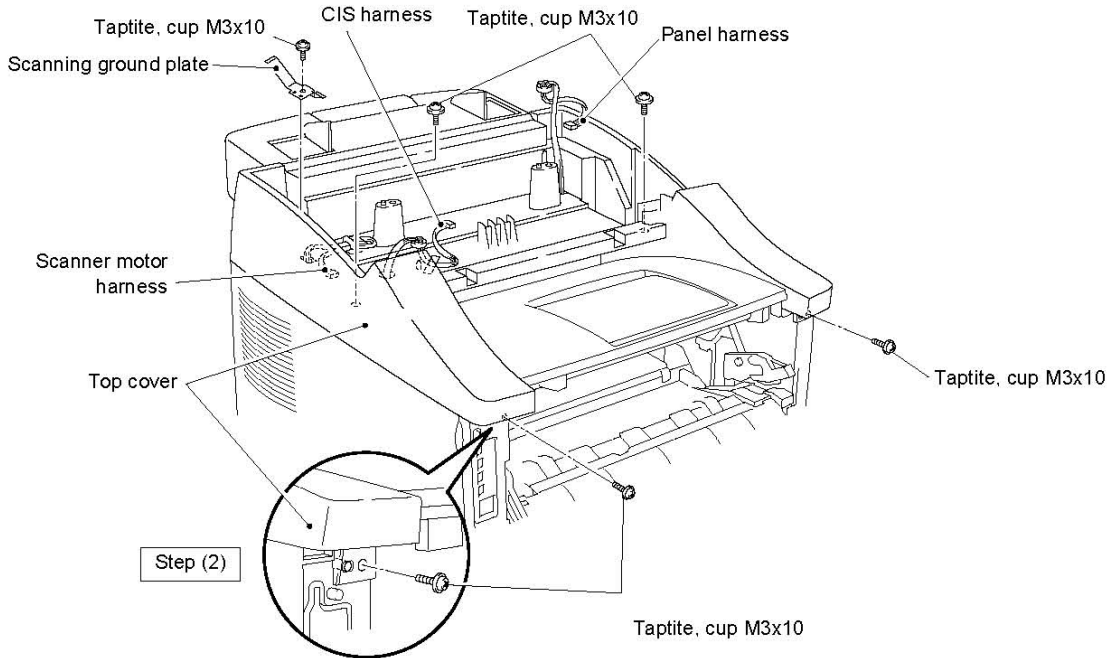

Fig. 4-31

NOTE:

When re-assembling the cores onto the panel harness and CIS harness, turn the harness through the core three times and fix the core into the boss on the top cover. Fix the CIS harness and scanner motor harness with tape. (Refer to the figure below.)

It is essential that the ferrite cores are refitted exactly as shown to ensure continued EMC compliance of the printer.

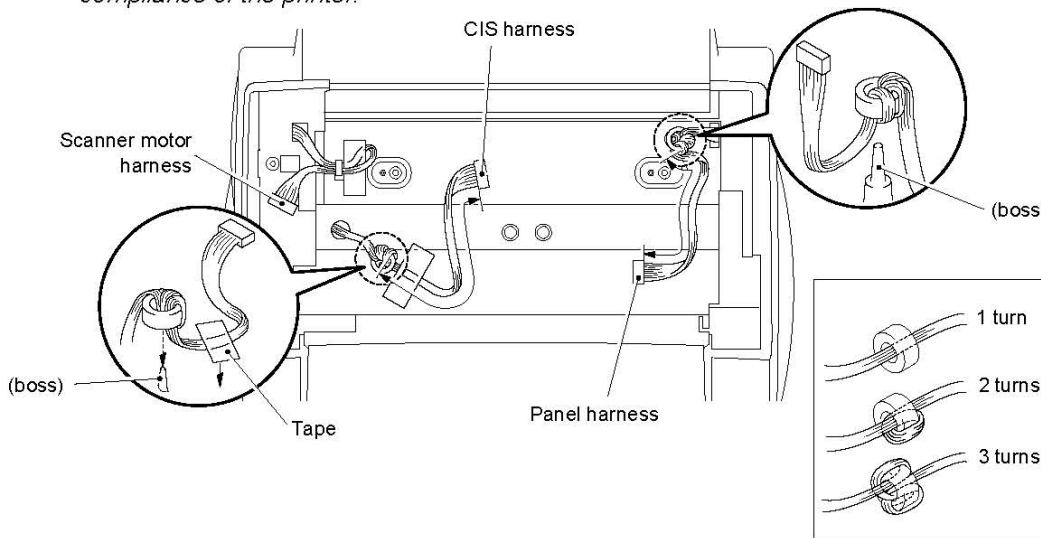

Fig. 4-32

- (4) Lift up the top cover and release the hooks at the right and left hand sides of the top cover to remove the top cover.

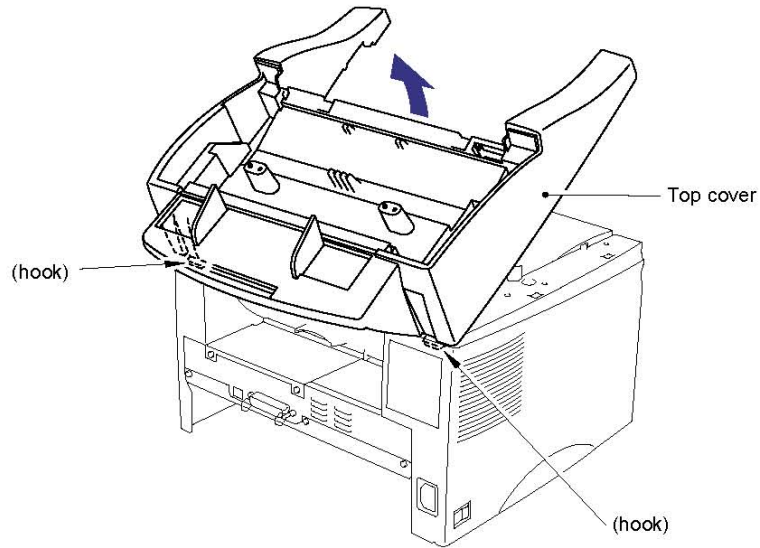

Fig. 4-33

- (5) Turn the top cover upside down and remove the second eject roller ASSY by lifting the middle of the roller upwards until the roller releases from the cover.

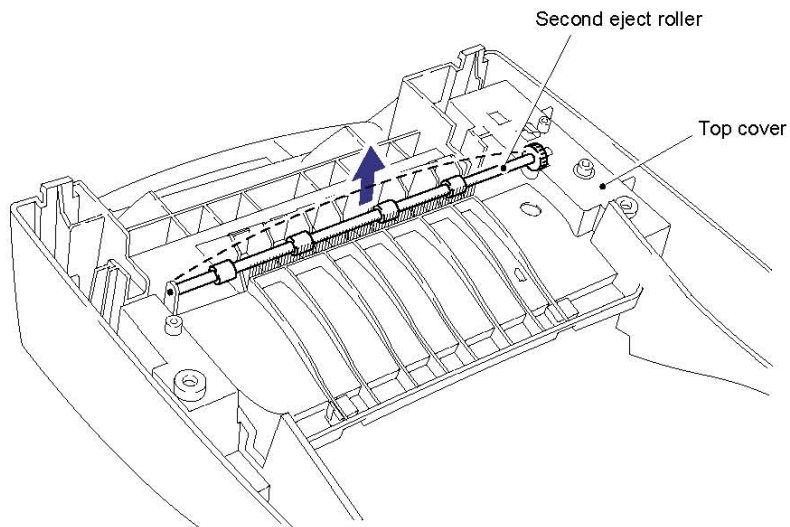

Fig. 4-34

- (6) Remove the M3x6 Taptite screw, then remove the guide gear and pressure spring.
- (7) Slide the document guides L/R to the centre and pull them upwards to remove them.

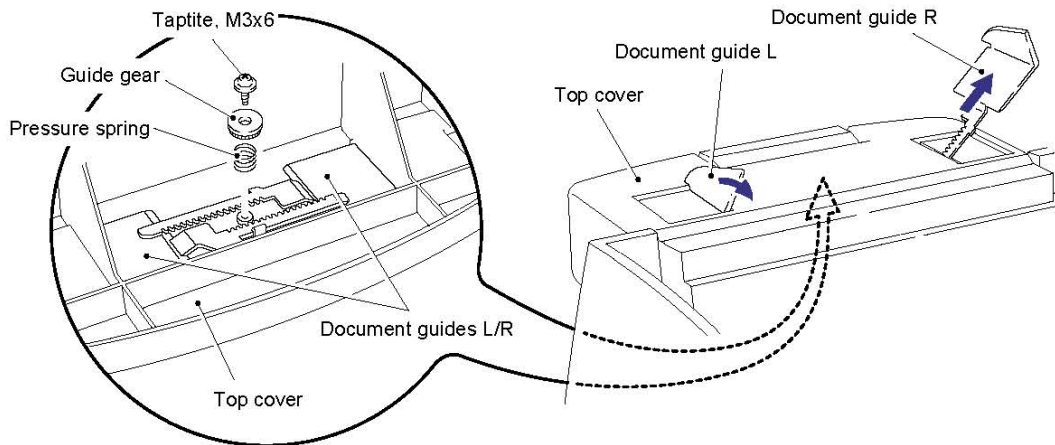

Fig. 4-35

NOTE:

When securing the M3x6 Taptite screw to hold the guide gear and spring, ensure that the guide gear and the gears of the document guides L/R are engaged.

3.8 Main Cover

- (1) Open the rear cover and remove the two M3x8 Taptite screws from the rear of the main cover.
- (2) Release the hooks at the right and left hand top sides of the printer, then, while pulling the cover outwards to clear the power socket and switch, lift up the main cover to remove it complete with the rear cover.

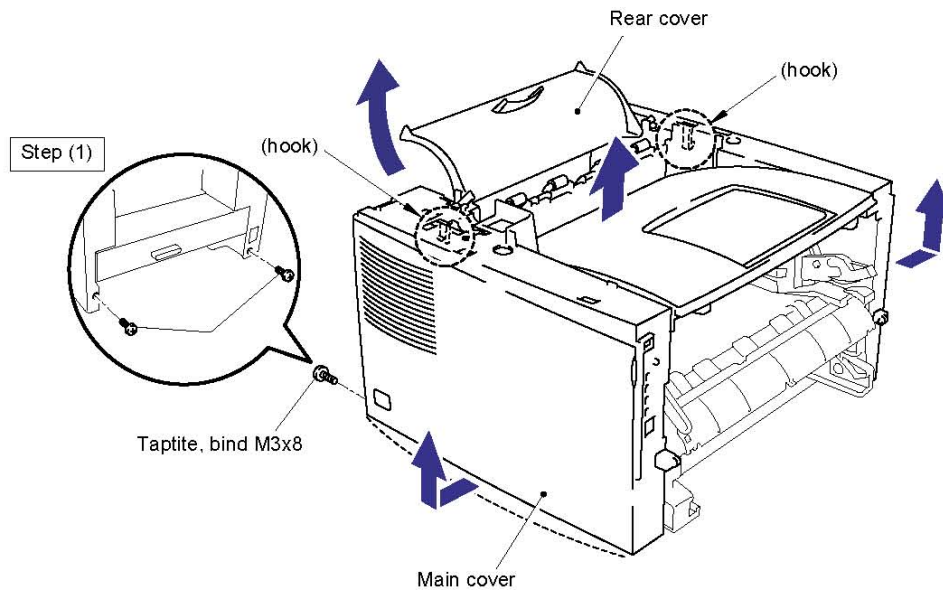

Fig. 4-36

- (3) Bend the tray extension flap upwards slightly to remove the tray extension flap.

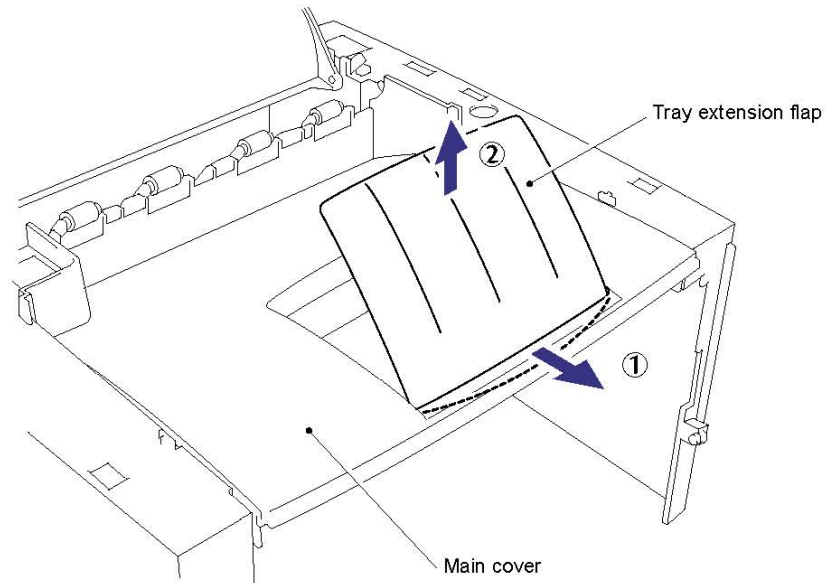

Fig. 4-37

- (4) Release the rear cover springs Left and Right from the hooks on the main cover.
- (5) Remove the rear cover complete with the rear cover springs Left and Right from the main cover.
- (6) Remove the four pinch rollers and four pinch roller springs by moving them to the vertical and then removing them by lifting them upwards.

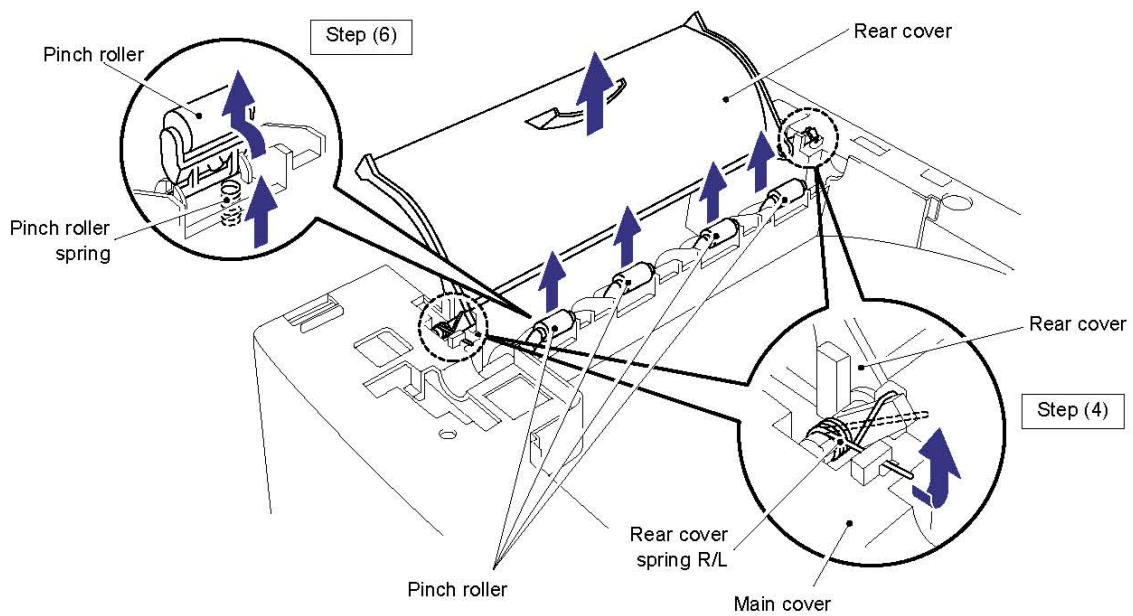

Fig. 4-38

3.9 Laser Unit

- (1) Remove the three M3x16 Taptite screws.
- (2) Push the P harness cover to the right to release it from the hook and remove the P harness cover.
- (3) Disconnect the LD harness and the polygon motor connector.
- (4) Taking care not to touch the lens and mirror, remove the laser unit.

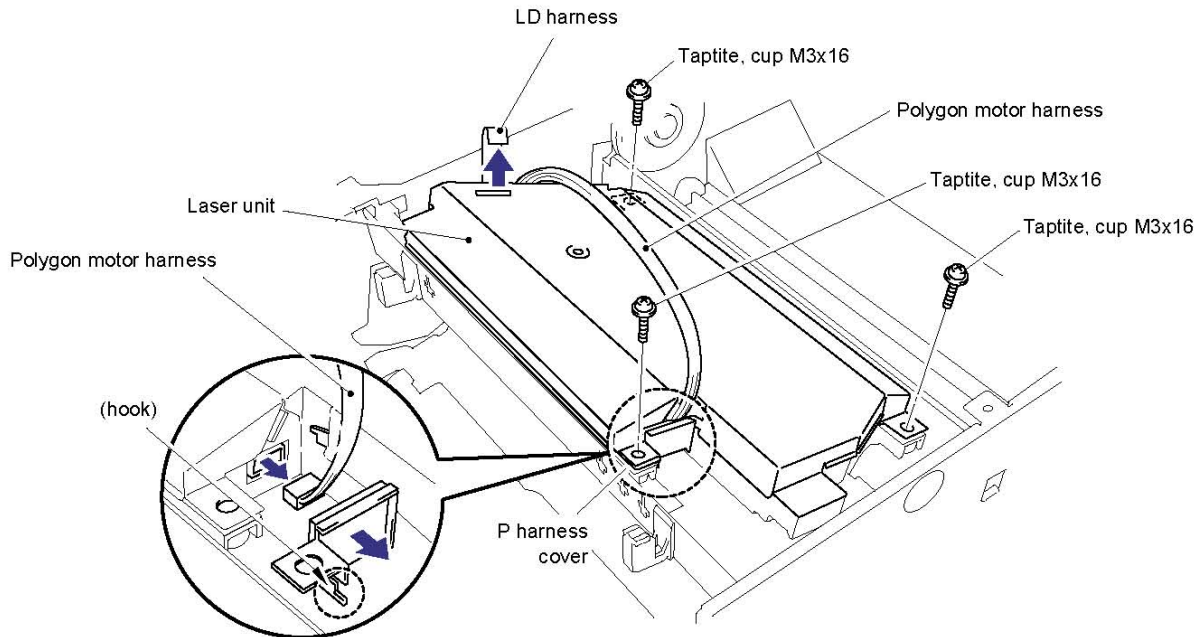

Fig. 4-39

⚠ CAUTION:

- Never touch the reflect mirror and lens inside the laser unit. If there is any dirt or dust on the mirror or lens, blow it off using an air gun.
- Never touch the scanner window on the printer body. If there is any dirt or dust on the window, blow it off using an air gun. If cleaning the underside of the scanner window, wipe off dirt or dust with soft clean paper. Refer to [subsection 3.3 'Cleaning the Scanner Window' in CHAPTER 5](#).

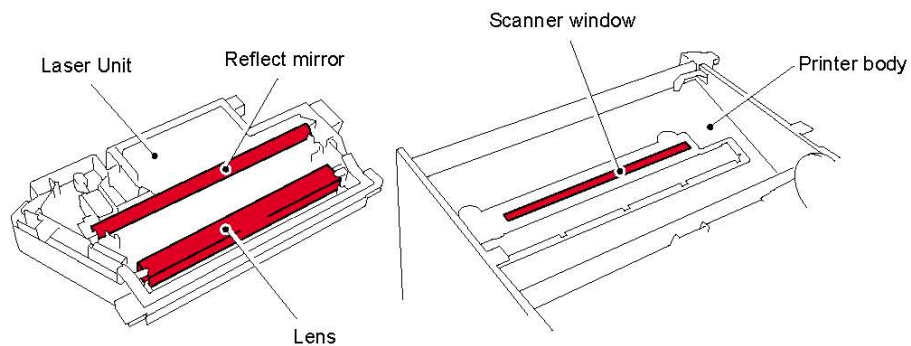

Fig. 4-40

3.10 Drive Unit

- (1) Place the printer body carefully on its right hand side so that the drive unit is at the top.
- (2) Remove the five M3x6 Taptite screws securing the gear plate.
- (3) Disconnect the heater harness connector and release the panel PCB harness from the hooks.
- (4) Carefully lift the drive unit and, while supporting the PCB, disconnect the main motor connector.
- (5) Remove the drive unit.

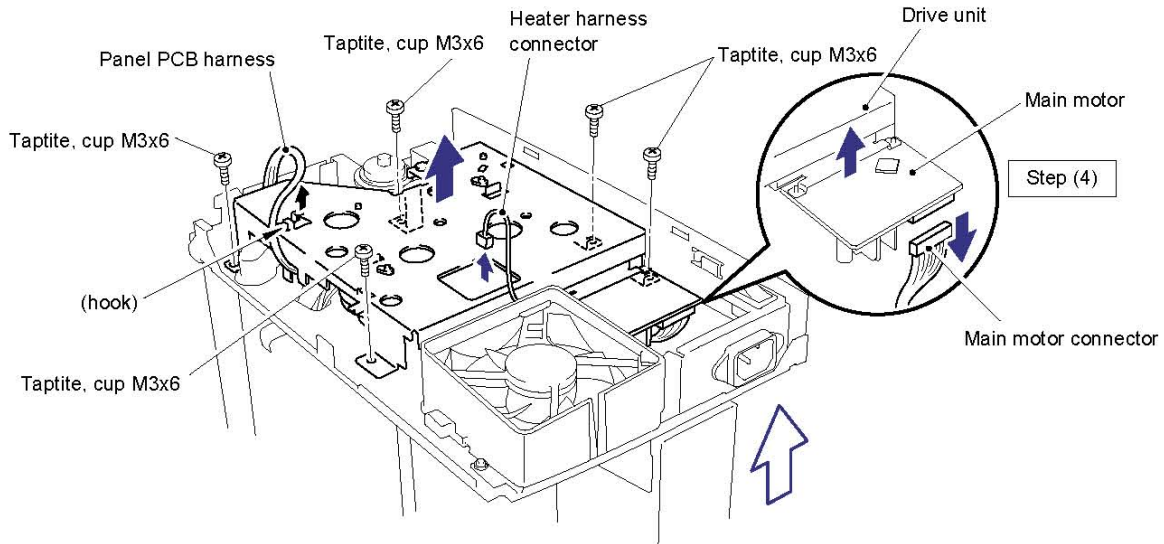

Fig. 4-41

- (6) Remove the four M3x6 Taptite screws to remove the main motor ASSY from the drive unit.

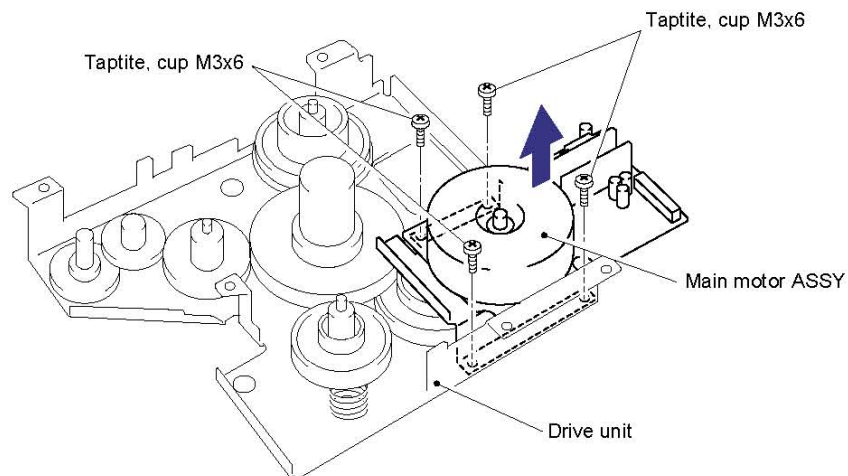

Fig. 4-42

- (7) Remove the development joint complete with the joint spring, then remove the link.

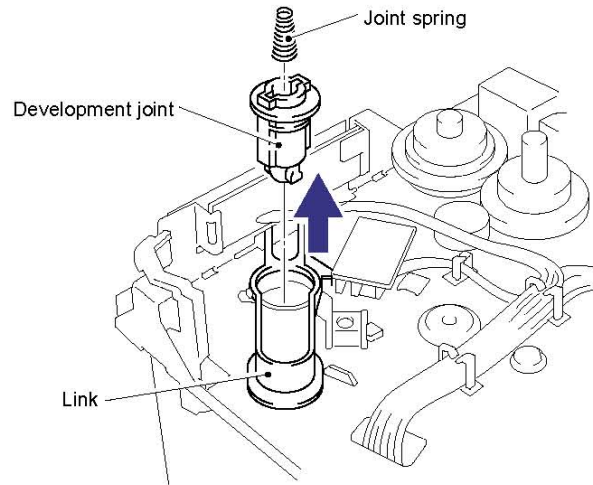

Fig. 4-43

3.11 Fixing Unit

- (1) Release the two harnesses from the hooks and remove the M3x6 Taptite screw, then remove the fan duct.

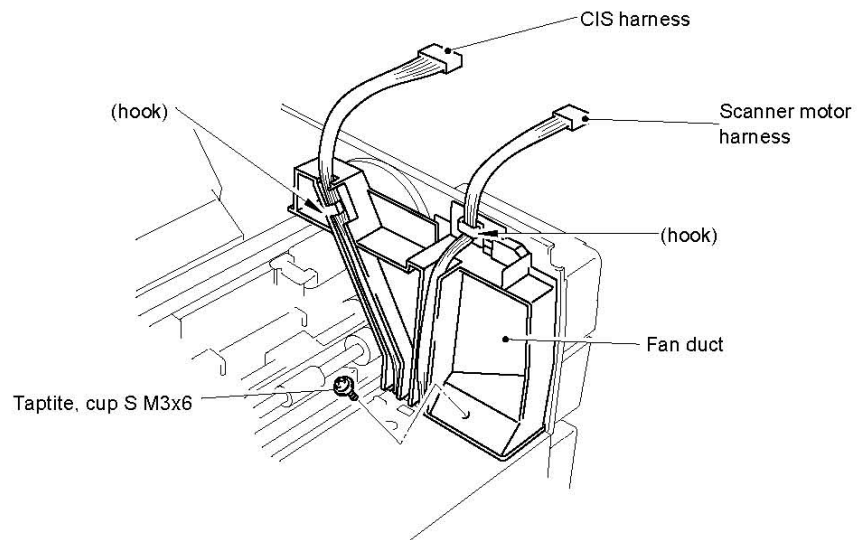

Fig. 4-44

- (2) Place the main frame on its base so that the rear side is facing you.
- (3) Press the two hooks inwards to remove gear 59.
- (4) Disconnect the two connectors of the heater harness and release the harness from the hooks on the top of the fixing unit.
- (5) Remove the one M3x8 Taptite screw and two shoulder screws securing the fixing unit, taking care not to lose the contact spring fitted to the front left hand shoulder screw.

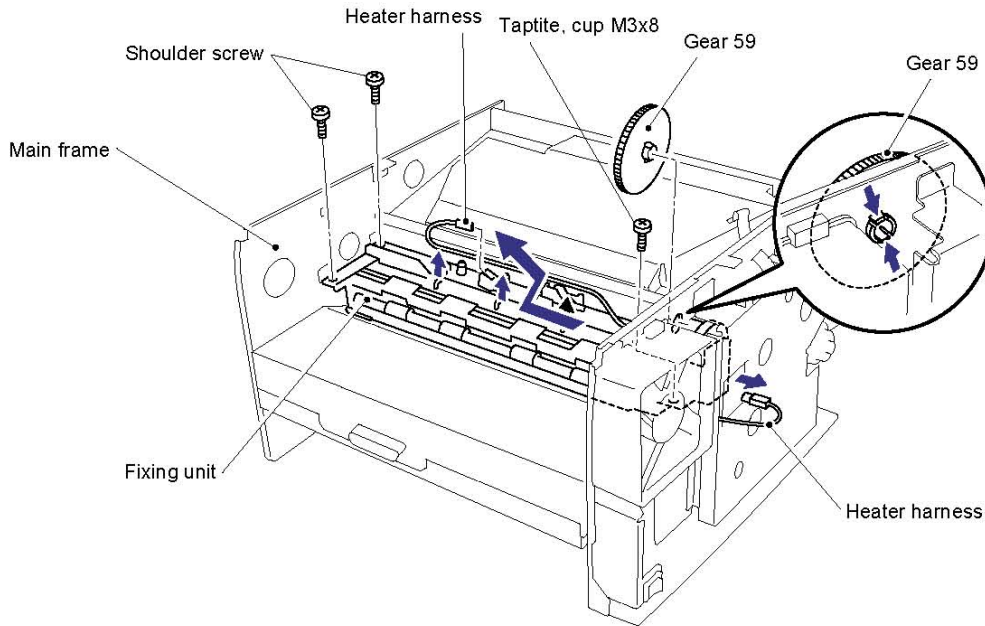

Fig. 4-45

NOTE:

When re-assembling the fixing unit, ensure you do not forget to refit gear 59.

- (6) Lift up the fixing unit and move it toward you and to the left to allow the drive gear to clear the frame and then disconnect the thermistor connector from the engine PCB.
- (7) Remove the fixing unit from the main frame.

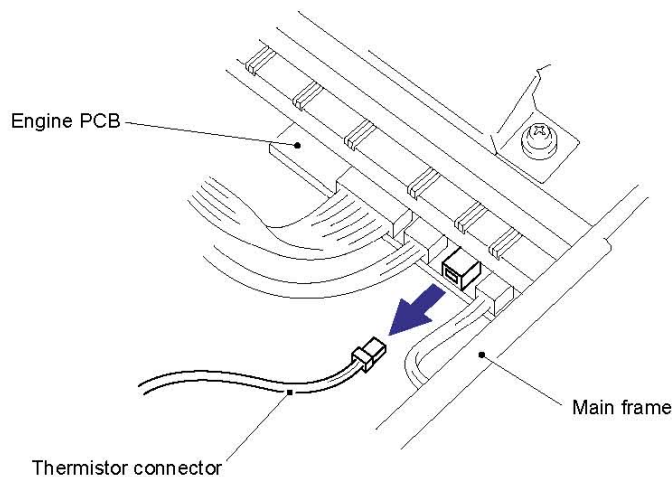

Fig. 4-46

NOTE:

When re-assembling the fixing unit, align the fixing unit frame at the drive unit side into the concave part of the main frame.

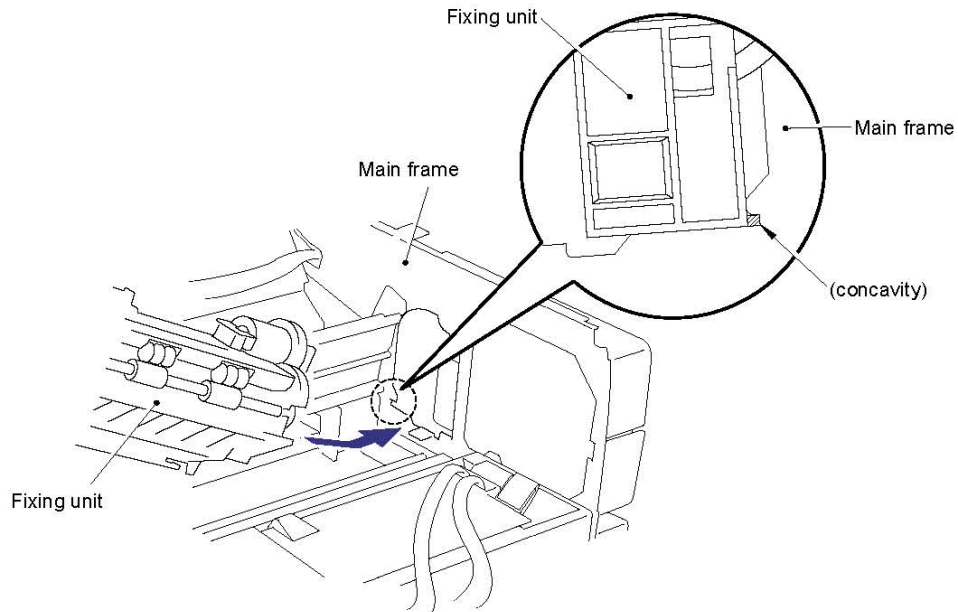

Fig. 4-47

- (8) Remove the M3x10 screw to remove the star wheel holder ASSY from the fixing unit by lifting the left hand end of the assembly slightly and then moving the assembly to the right to release the right hand end from the fixing unit frame.

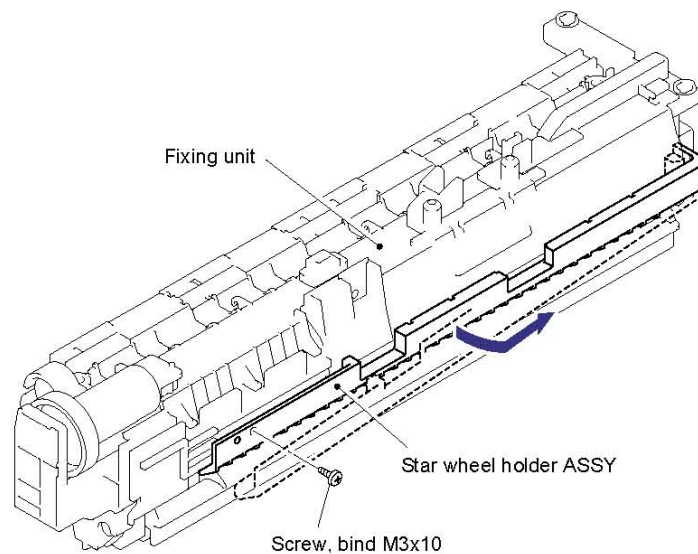

Fig. 4-48

- (9) Remove the two M3x20 Taptite screws from the top of the fixing unit frame.
- (10) Release the thermistor harness from the hooks.
- (11) Release the two hooks at the right and left sides securing the fixing unit cover to the fixing unit frame.

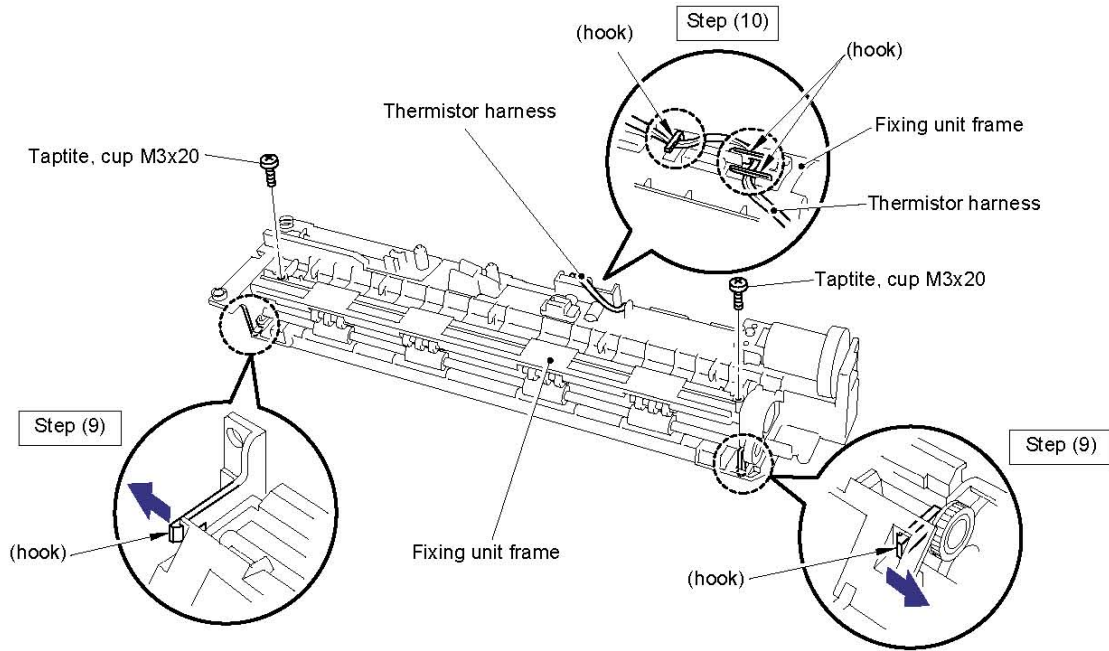

Fig. 4-49

- (12) Remove the fixing unit cover from the fixing unit frame.

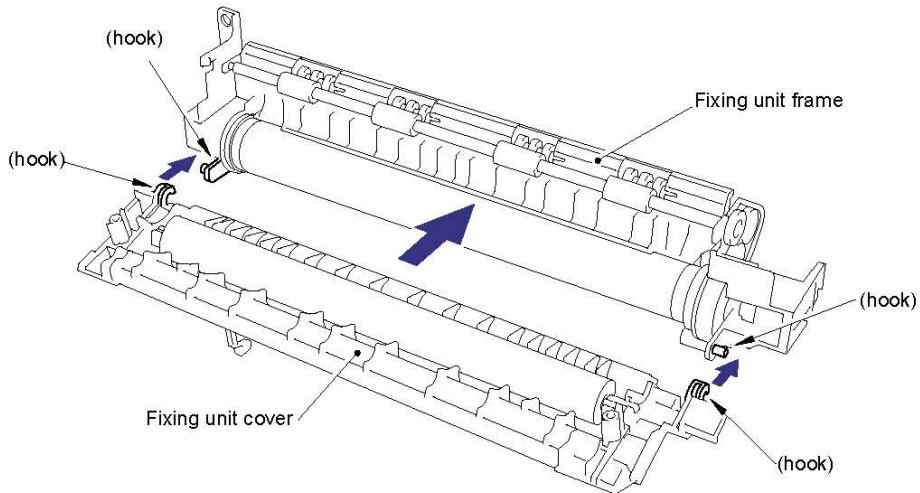

Fig. 4-50

- (13) Remove the one M3x10 Taptite screw securing the halogen lamp connector plate at the drive unit side of the fixing unit frame and loosen the M3x6 screw at the other side.
- (14) Lift the right hand end of the heat roller and remove the halogen heater lamp from the heat roller.

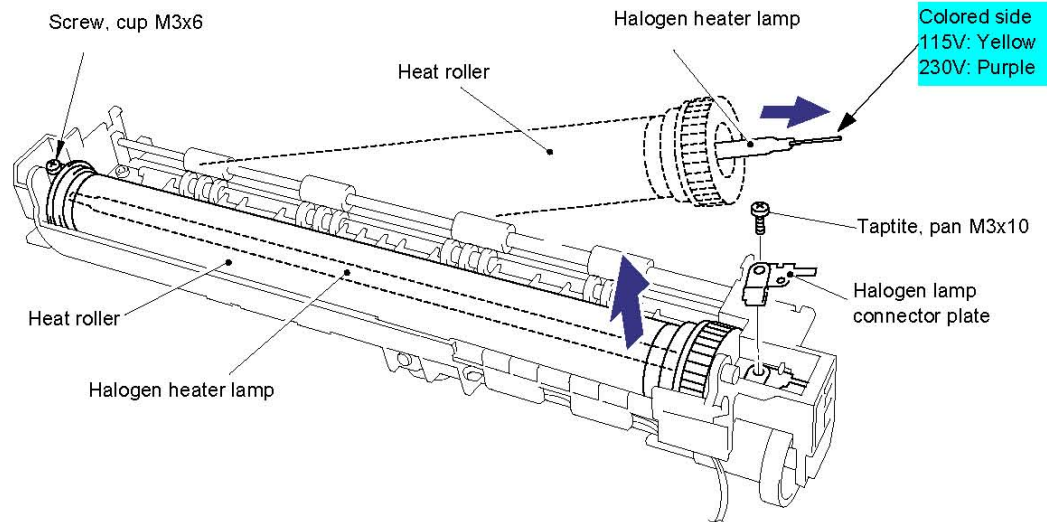

Fig. 4-51

NOTE:

When re-assembling the halogen heater lamp, ensure that the direction of the halogen heater lamp is correct referring to the figure above.

CAUTION:

- Never touch the surface of the halogen heater lamp.
- When securing the screw to assemble the halogen lamp connector plate, ensure you use the plastic jig as shown in the figure below to avoid damaging the end of the halogen heater lamp.

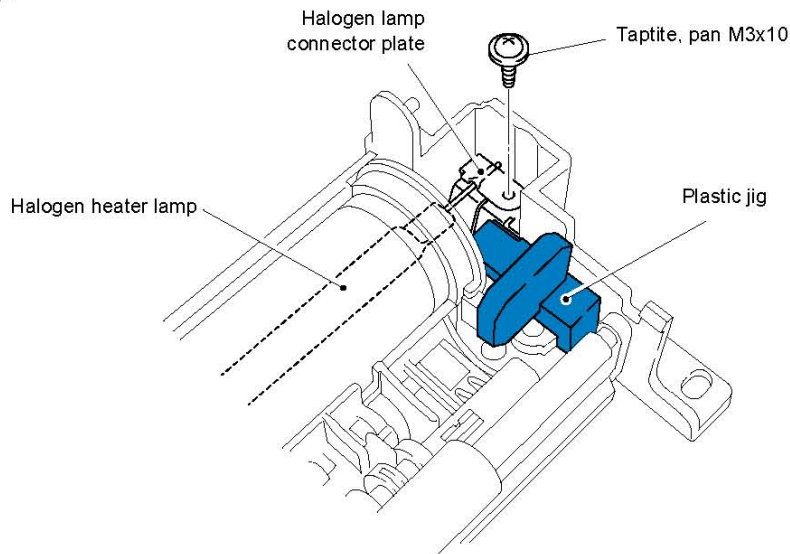

Fig. 4-52

- (15) Lift and remove the heat roller. The heat roller gear will also come off.
- (16) Remove the heat roller bearing from the left hand end of the heat roller. To remove the bearing at the gear side, first remove the two washers, then remove the bearing.

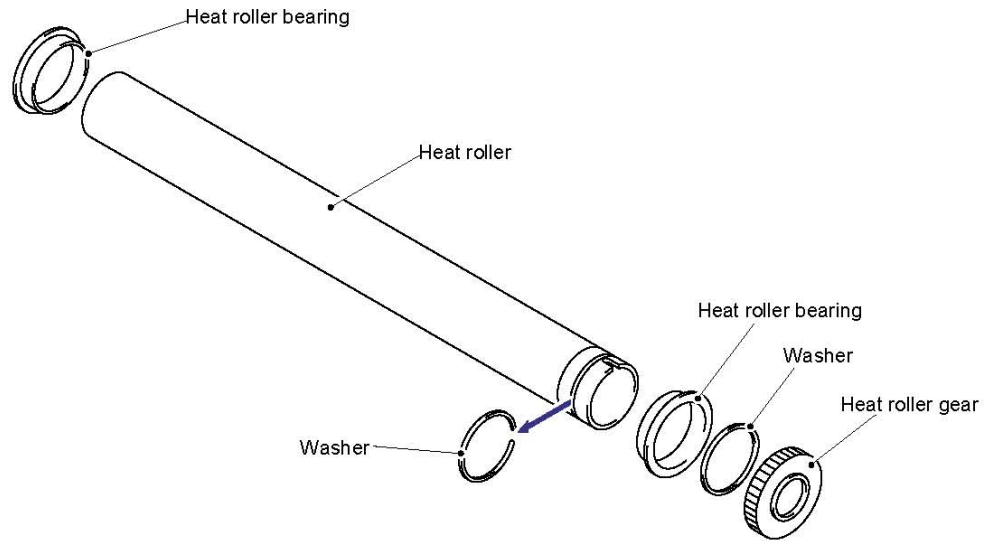

Fig. 4-53

CAUTION:

Never touch the surface of the heat roller.

NOTE:

- *When re-assembling the heat roller to the fixing unit frame, place the two projections at the right hand side of the roller onto the bosses on the frame as shown in the figure below.*

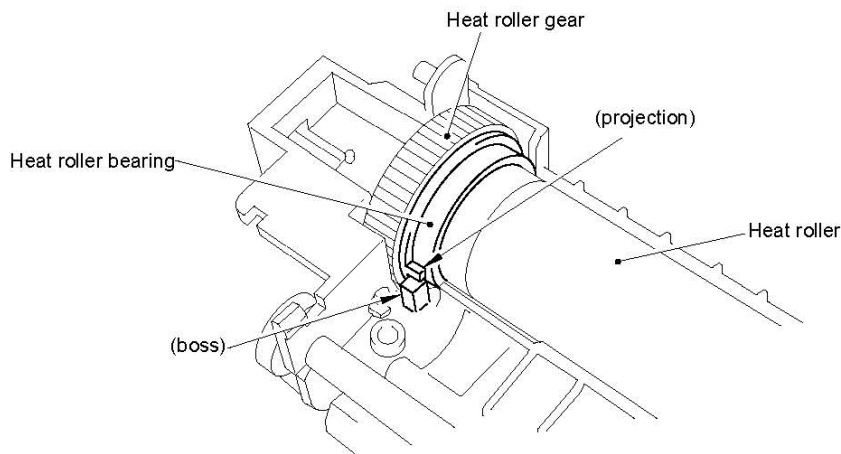

Fig. 4-54

- When re-fitting the heat roller bearing assembly at the heat roller gear side, fit the bearing onto the heat roller so that the bearing cutout is at the top.

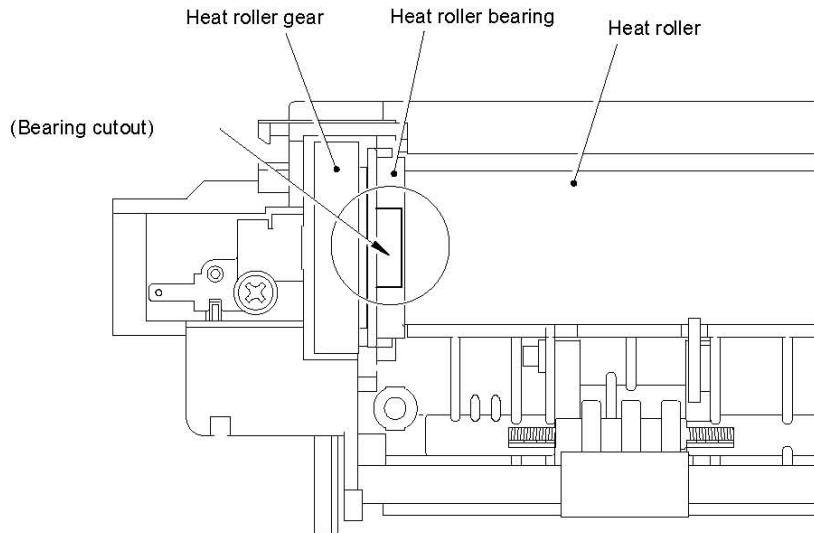

Fig. 4-55

- When re-assembling the heat roller to the fixing unit frame, ensure you do not damage the heat roller with the four hooks on the fixing unit frame.

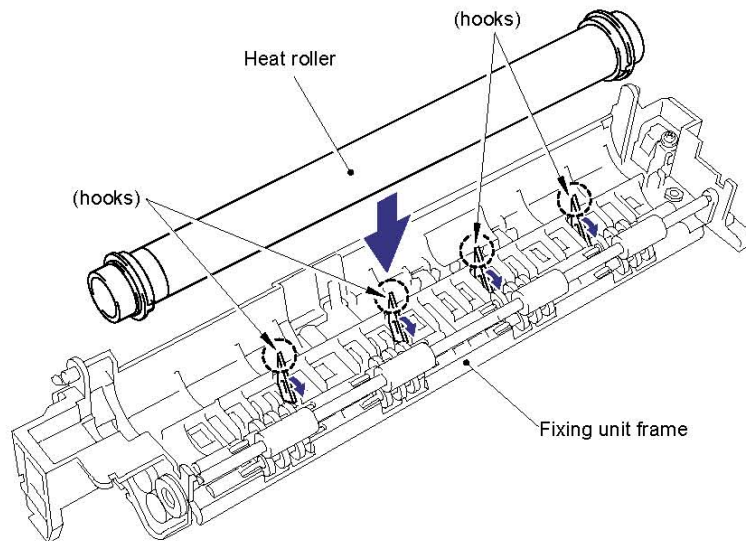

Fig. 4-56

- (17) Remove the heat roller cleaner complete with the cleaner spring from the fixing unit frame by lifting it upwards until the spring releases from the frame.
- (18) Remove the cleaner spring from the heat roller cleaner.

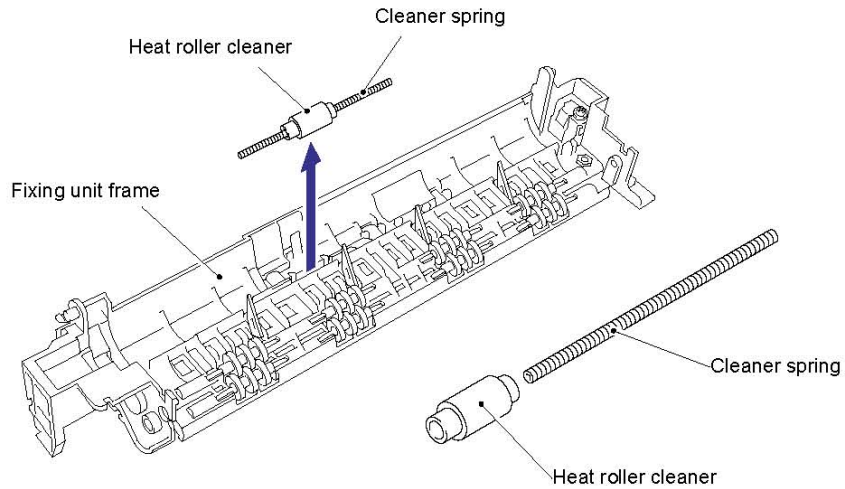

Fig. 4-57

NOTE:

- When re-assembling the heat roller cleaner complete with the cleaner spring onto the fixing unit frame, ensure the direction of the roller is correct referring to the figure above.
- Ensure also that the spring is seated correctly in the locating channel and does not protrude from either end.

- (19) Remove the pressure roller from the fixing unit cover by gently levering the right hand side upwards to release it from the bearing and then sliding it to the right to remove it.
- (20) Remove the pressure roller cleaner complete with the cleaner spring from the fixing unit cover by lifting it upwards until the spring releases from the cover.
- (21) Remove the cleaner spring from the pressure roller cleaner.

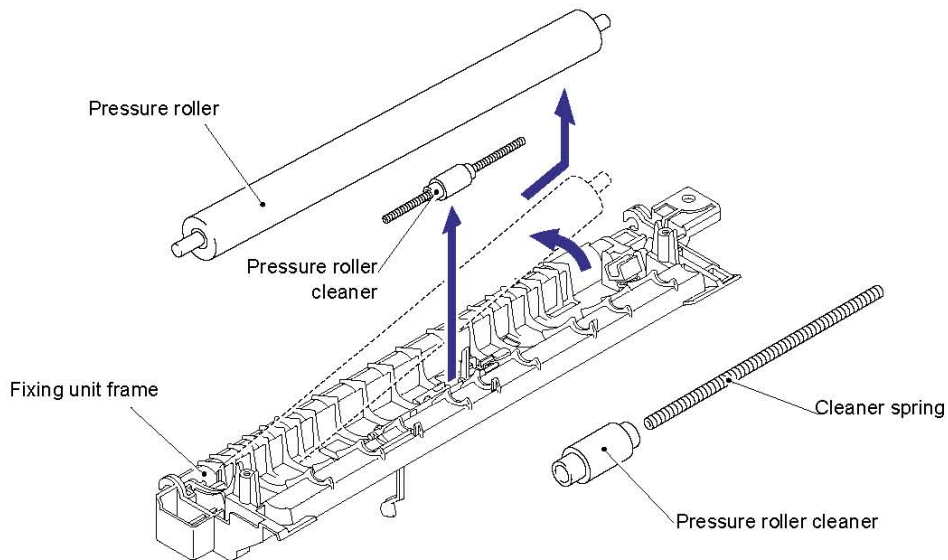

Fig. 4-58

NOTE:

- When re-assembling the pressure roller cleaner complete with the cleaner spring onto the fixing unit cover, ensure the direction of the roller is correct referring to the figure above.
- Ensure also that the spring is seated correctly in the locating channel and does not protrude from either end.

(22) Release the thermistor harness from the hooks on the fixing unit frame and then remove the one M3x12 Taptite screw and remove the thermistor.

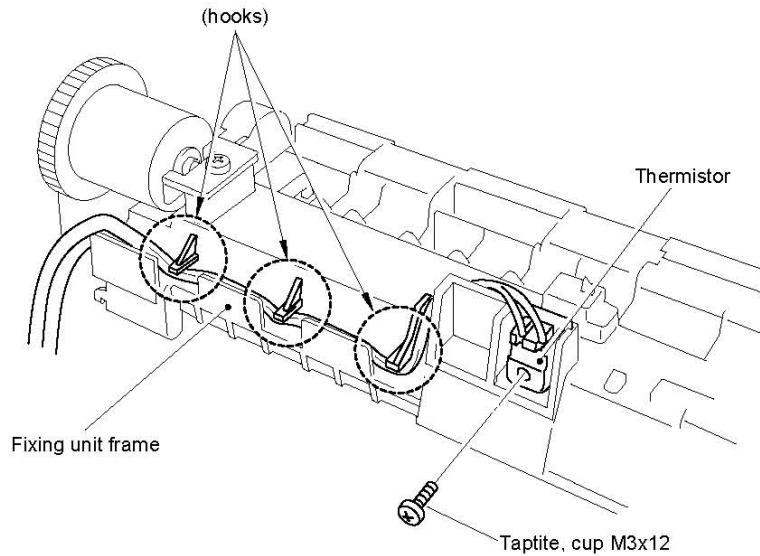

Fig. 4-59

NOTE:

When re-assembling the thermistor to the fixing unit frame, ensure the direction of the thermistor is correct referring to the figure below;

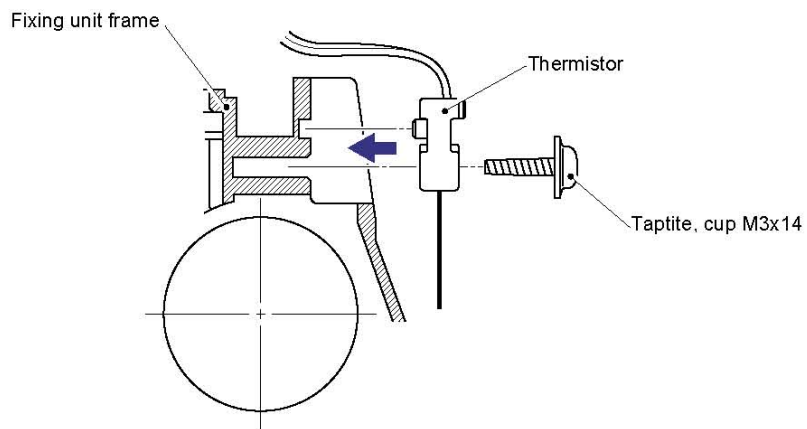

Fig. 4-60

- (23) Press the two catches holding the idle gear 13 to the frame and then remove the idle gear 13. Slide the first eject roller to the left until the slot in the roller shaft aligns with the slot in the frame and then remove the roller by pulling it forwards.

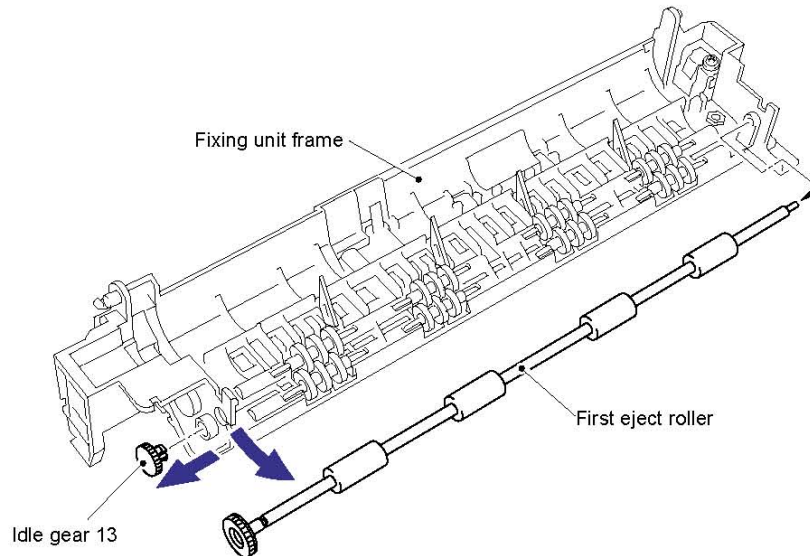

Fig. 4-61

- (24) Remove the eight eject pinch rollers and pinch springs by lifting them upwards until the springs release from the frame.

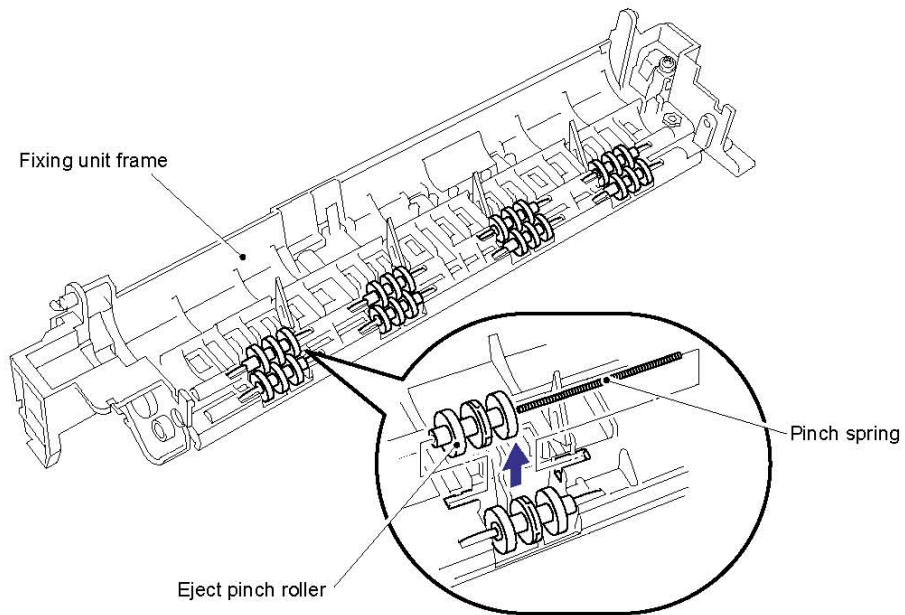

Fig. 4-62

3.12 Base Plate

- (1) Turn the main frame upside down.
- (2) Remove the five M4x10 Taptite screws and 16 (sixteen) M3x8 Taptite screws from the base plate.
- (3) Slide the base plate to the rear of the printer to remove it.

CAUTION:

Do not remove the ground wire connected to the base plate if it is not necessary to remove the low-voltage power supply unit. Unnecessary disconnection of the ground wire may cause increased printer noise.

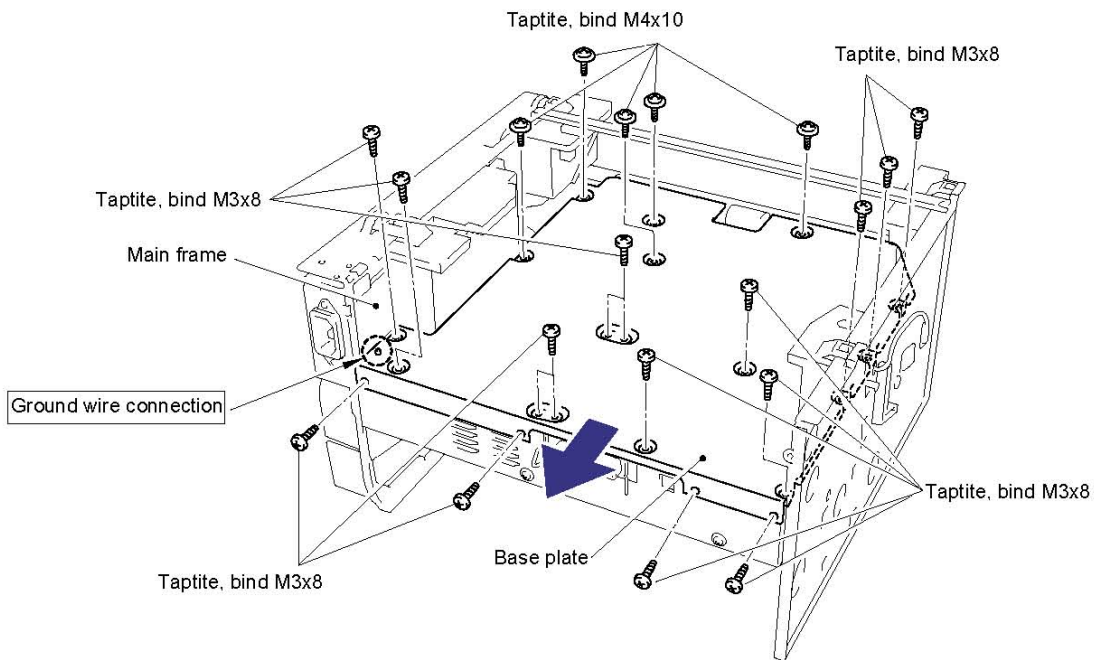

Fig. 4-63

CAUTION:

When re-assembling the base plate, be sure that the ground wire connected to the paper feed roller ASSY is fixed into the slit on the plastic chute referring to the figure below;

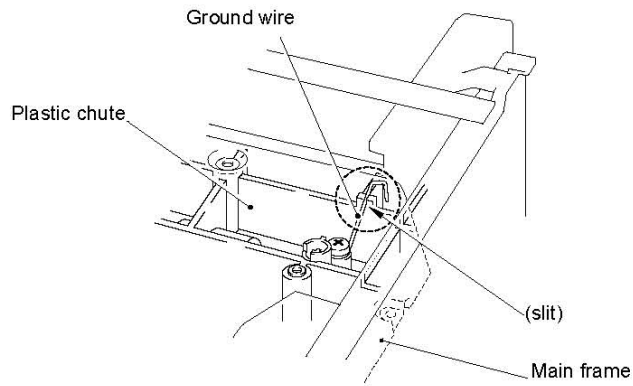

Fig. 4-64

- When securing the screws to assemble the base plate, ensure you use the jig shaft referring to the figure below so that the engine PCB is assembled correctly;

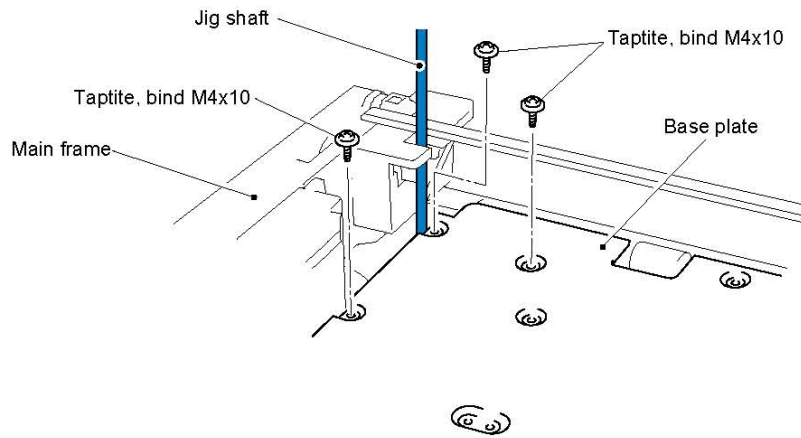

Fig. 4-65

3.13 Main PCB ASSY

NOTE:

Ensure that any installed memory board is removed *BEFORE* removing the main PCB.

- (1) Remove the two M3x8 screws from the I/F plate to release the main PCB.
- (2) Lift the insulation sheet and remove the main PCB ASSY.
- (3) Disconnect the five connectors for the scanner motor, low-voltage power supply, CIS, engine PCB, LD and control panel.

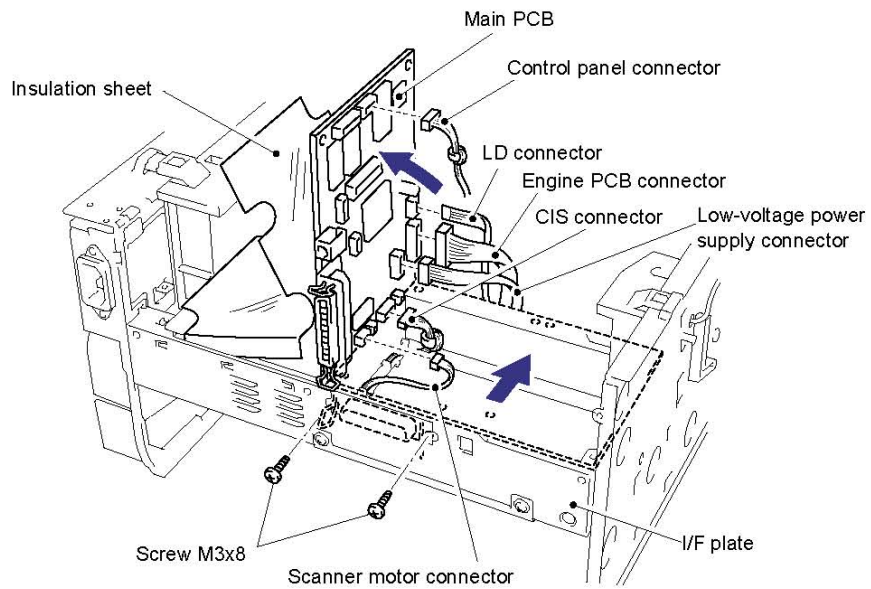

Fig. 4-66

NOTE:

When re-assembling the main PCB, fit the PCB onto the positioning boss as shown in the figure below. Failure to do so may cause poor print quality.

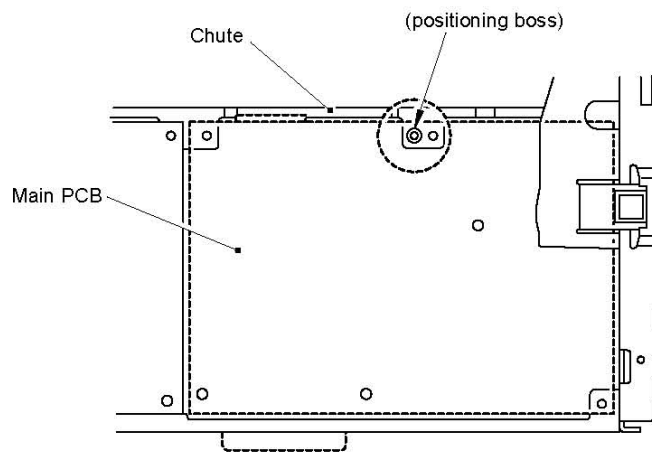

Fig. 4-67

3.14 Lower Tray Relay PCB ASSY

- (1) Remove the M3x6 Taptite screw and remove the lower tray relay PCB ASSY.

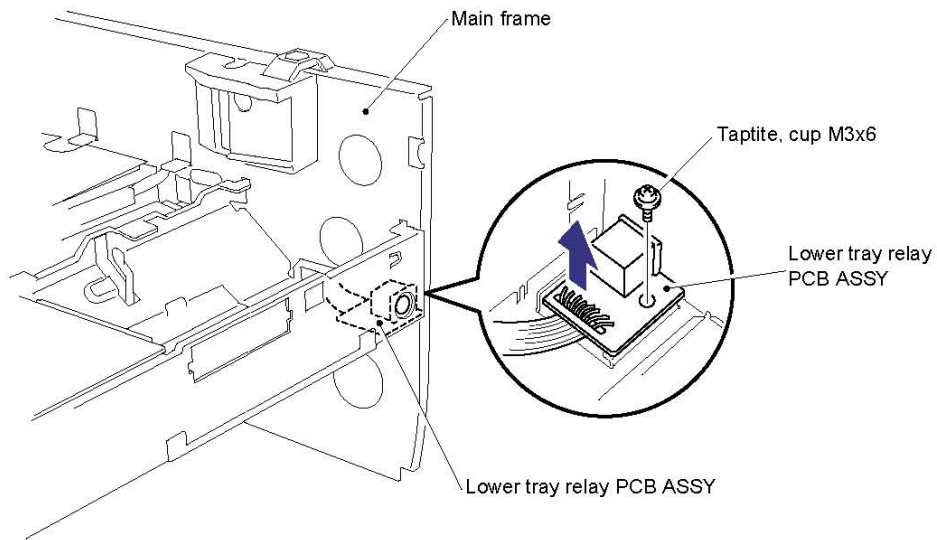

Fig. 4-68

3.15 Low-Voltage Power Supply PCB ASSY

- (1) Remove the M3x8 Taptite screw to remove the insulation sheet.
- (2) Slightly lift up the low-voltage power supply PCB ASSY from the frame and disconnect the engine PCB connector. Then lift the power supply PCB ASSY further and disconnect the halogen heater lamp connector.
- (3) Remove the M3.5x6 screw to disconnect the ground wire from the base plate.

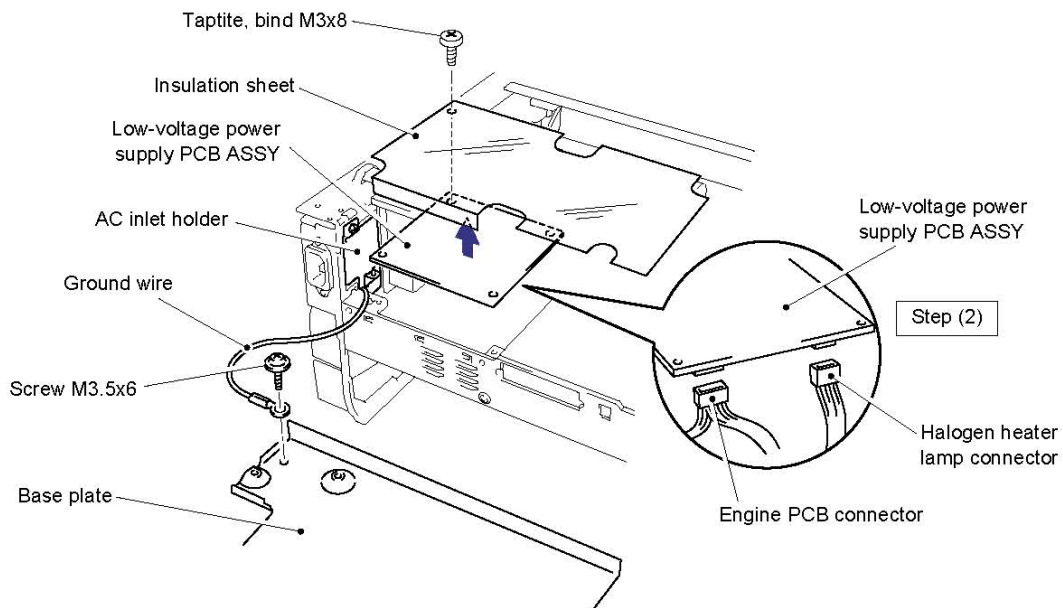

Fig. 4-69

- (4) Remove the M3x6 Taptite screw securing the AC inlet holder.
- (5) Turn the AC inlet to the right to release it and remove the AC inlet ASSY and the low-voltage power supply PCB together.

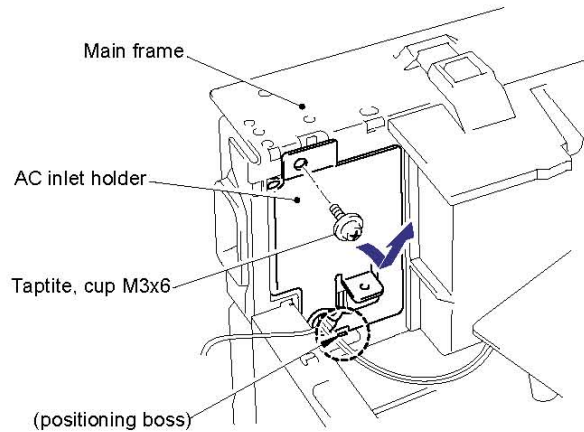

Fig. 4-70

NOTE:

When re-assembling the AC inlet holder, fix the holder onto the positioning bosses first, then secure it to the frame with the screw. (Refer to the figure above.)

CAUTION:

Be sure to attach the film to the AC inlet ASSY in the following cases referring to the figure below;

- If the film is not attached to the AC inlet on the printer you are servicing.
- If the film is damaged, or the adhesive is weak.

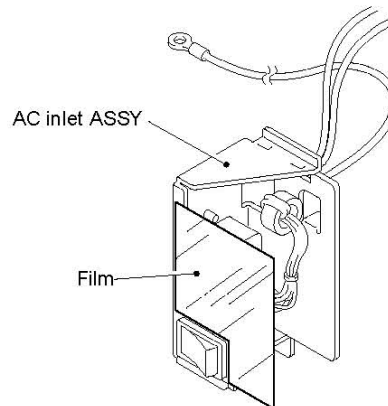

Fig. 4-71

3.16 Engine PCB ASSY / High-Voltage Power Supply PCB ASSY

- (1) Remove the M4x12 Taptite screw to remove the insulation sheet.
- (2) Remove the three M4x12 Taptite screws securing the engine PCB and the high-voltage power supply PCB.
- (3) Lift the engine PCB and high-voltage power supply PCB together and disconnect the connector which connects the two PCBs together to remove the high-voltage power supply PCB ASSY.
- (4) If necessary, remove the T/R electrode helical spring from the T/R plate.

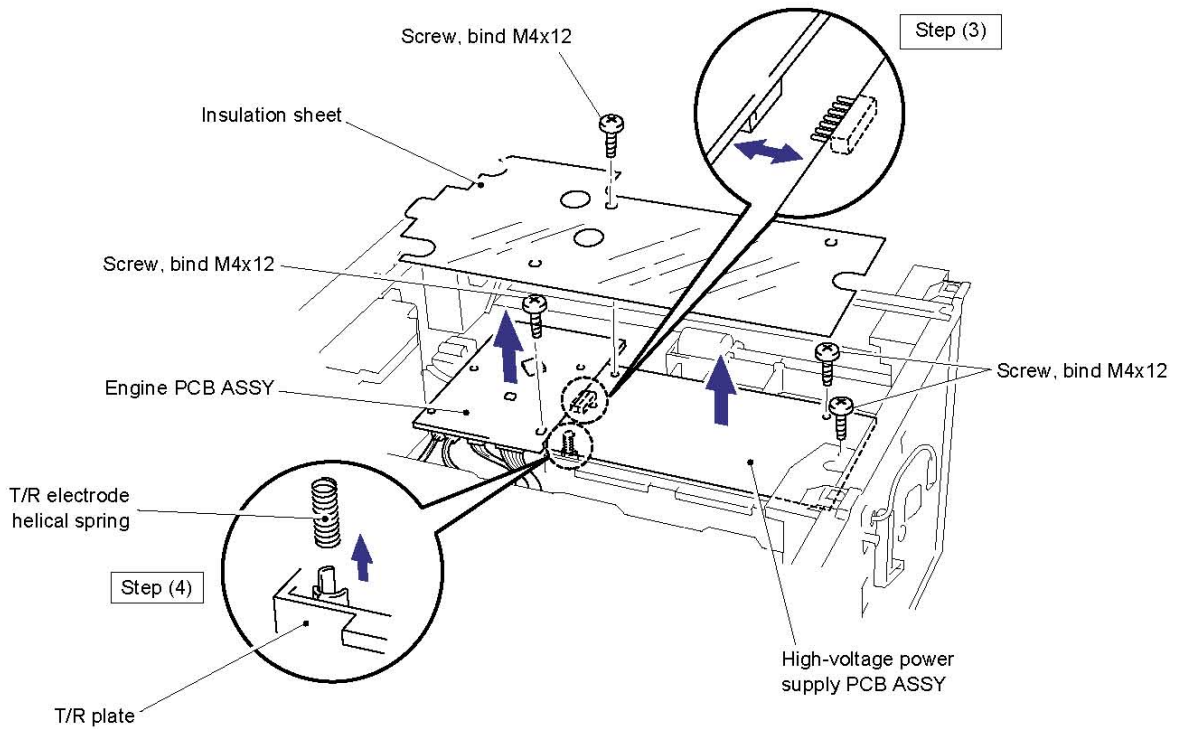

Fig. 4-72

CAUTION:

Be sure not to lose the T/R electrode helical spring after removing it.

NOTE:

When re-assembling the T/R electrode helical spring onto the plate, press the spring onto the plate firmly with a flat bladed screwdriver and ensure that it is retained securely.

- (5) Disconnect the 12 (twelve) connectors from the engine PCB to remove the engine PCB ASSY.

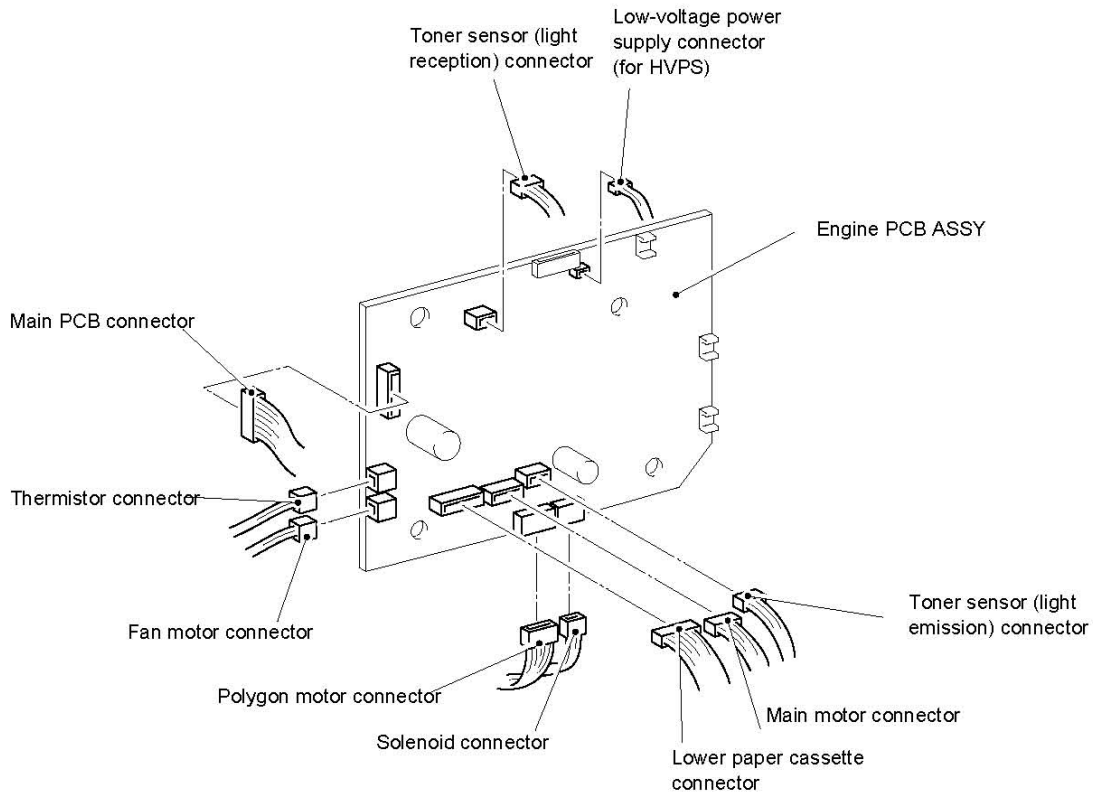

Fig. 4-73

CAUTION:

- Even if you want to remove only one of either the engine and/or high-voltage power supply PCBs, ensure you remove all screws securing both PCBs and disconnect the central connector while lifting both of them up. Failure to do so may damage the PCBs.
- When re-assembling the engine PCB, ensure it is aligned with the positioning boss first. Be careful the main motor harness is not caught between the engine PCB and the frame.
- When re-assembling the engine PCB or high-voltage power supply PCB, ensure the central connector is connected correctly.

3.17 Solenoid ASSY

NOTE:

Be sure to remove the drive unit and disconnect the solenoid connector on the engine PCB before removing the solenoid ASSY.

- (1) Place the main frame so that the drive unit side is at the top.
- (2) Release the catch and remove the planetary gear from the paper pick-up roller shaft.
- (3) Remove the planetary gear from the paper feed roller shaft and gear 56.

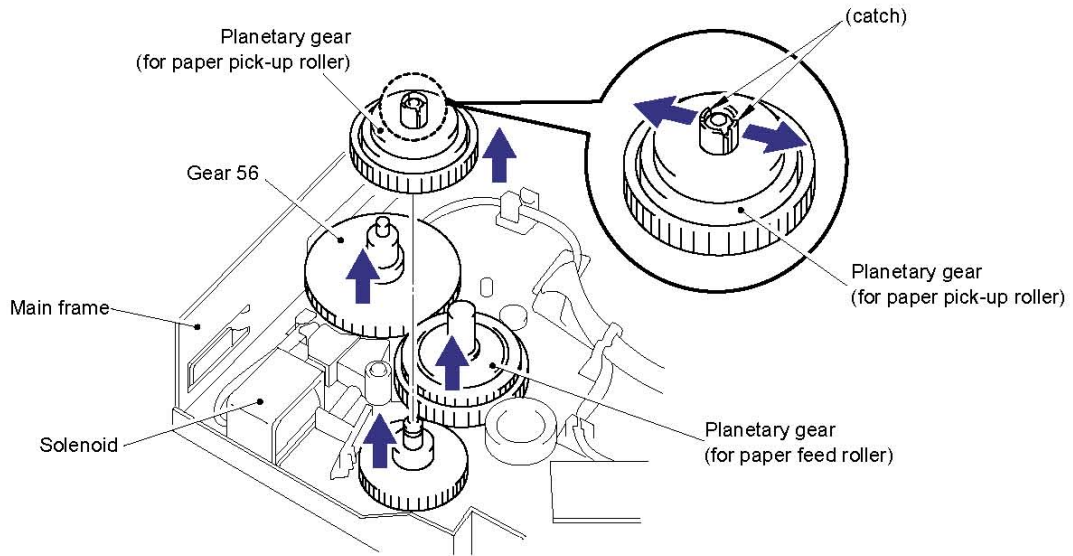

Fig. 4-74

- (4) Release the catch and remove the clutch levers for the feed roller and pick-up roller.

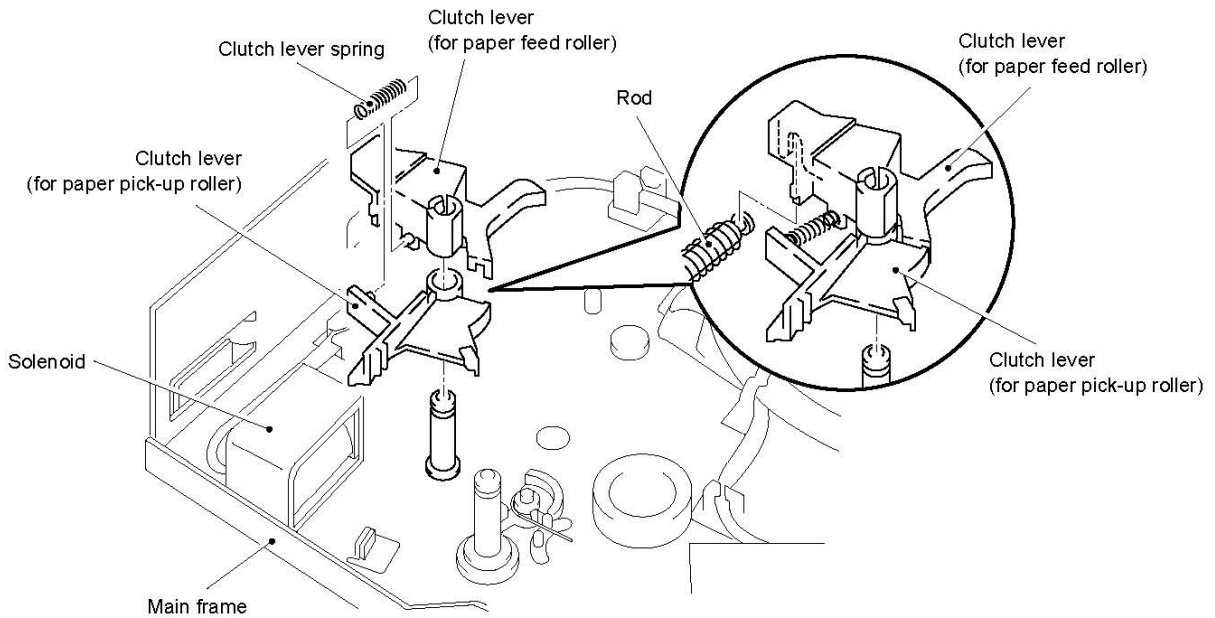

Fig. 4-75

CAUTION:

- When removing the clutch levers, the clutch lever spring may come off. Be sure not to lose it.
- When re-assembling the clutch lever for the paper feed roller, ensure that the U shaped groove of the lever is fitted onto the rod in the solenoid correctly referring to the figure in the previous page.

- (5) Place the main frame the right way up and remove gear 59 if not removed earlier during fixing unit removal.

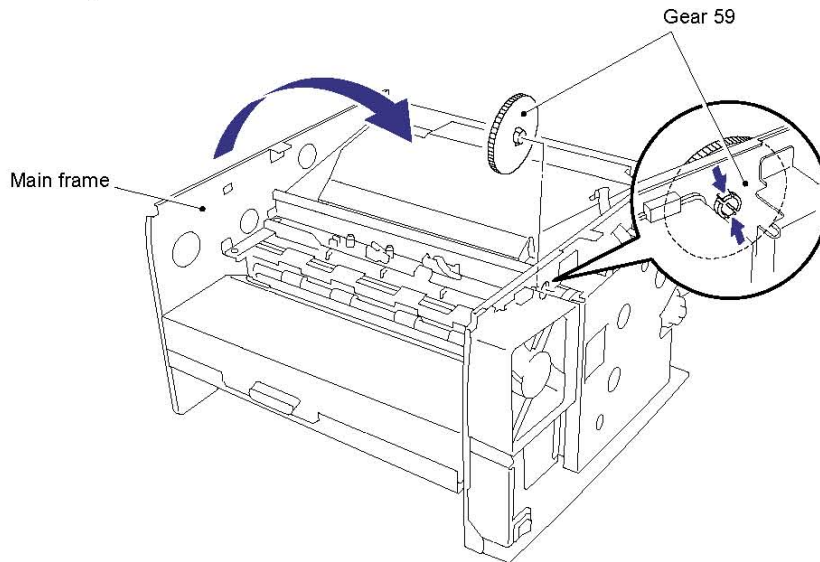

Fig. 4-76

NOTE:

When re-assembling the solenoid, ensure you do not forget to refit gear 59.

- (6) Turn the main frame upside down.
- (7) Remove the two M3x6 Taptite screws and release the solenoid harness from the hook and remove the cassette guide L/F.

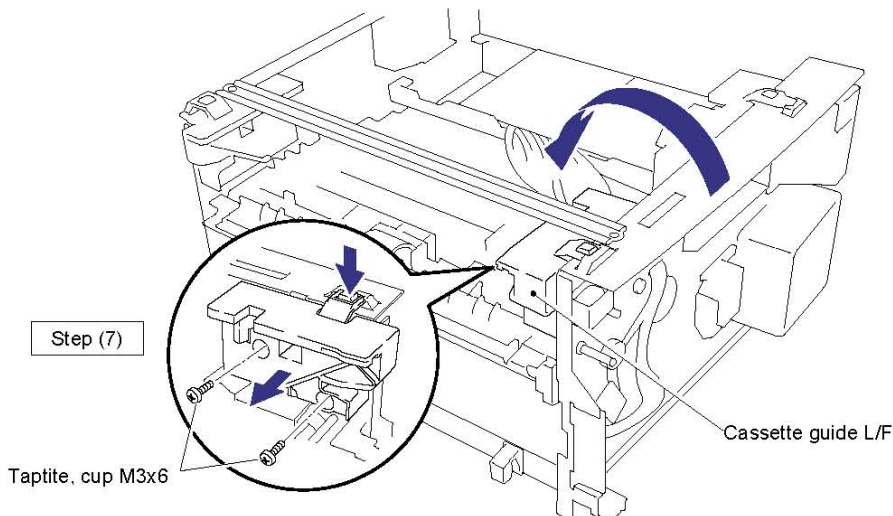

Fig. 4-77

- (8) Remove the M3x4 screw and the tape on the solenoid harness and remove the solenoid ASSY.

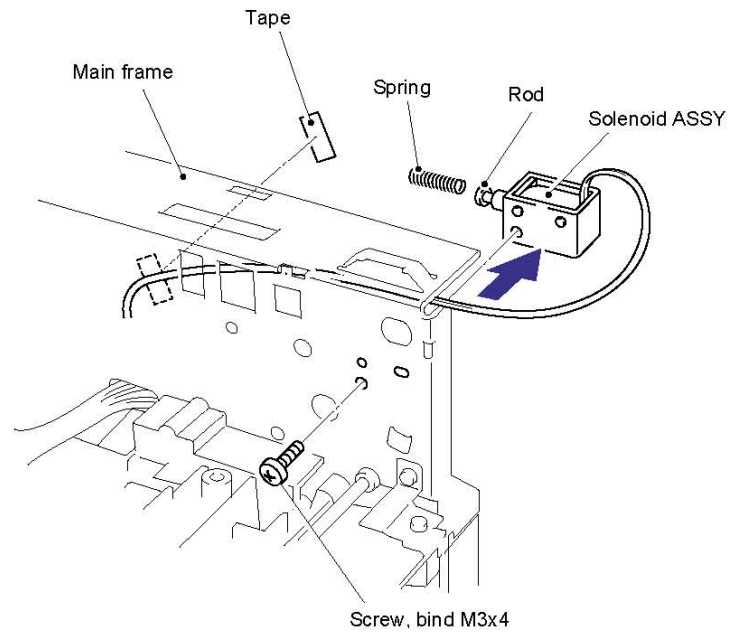

Fig. 4-78

CAUTION:

When removing the solenoid, the solenoid rod and spring may come off. Be careful not to lose them. (Refer to the figure above.)

3.18 Fan Motor ASSY

NOTE:

Be sure to remove the fixing unit and disconnect the fan motor connector on the engine PCB before removing the fan motor ASSY.

- (1) Place the main frame so that the fan motor ASSY is at the top.
- (2) Remove the two M3x6 Taptite screws securing the fan cover.
- (3) Remove the fan motor ASSY with the fan cover and remove the fan motor ASSY from the cover.

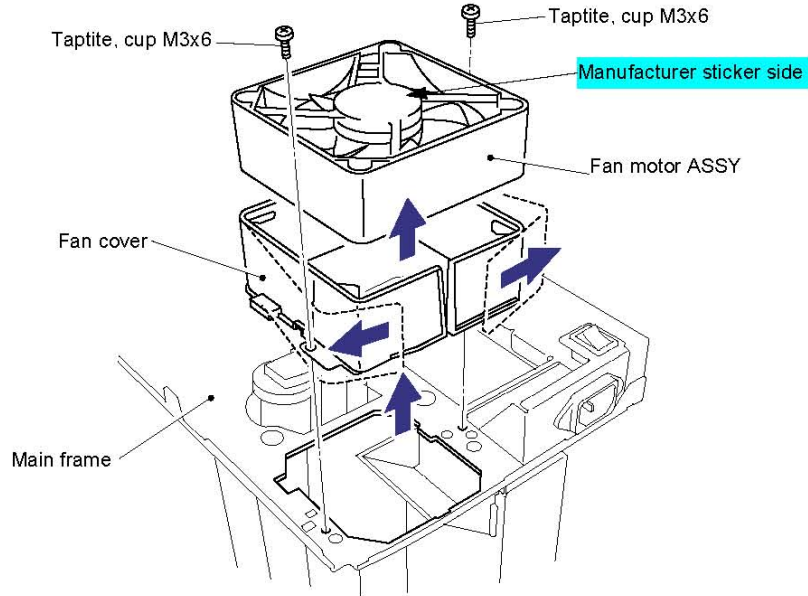

Fig. 4-79

NOTE:

When re-assembling the fan motor, fix the harness into the groove on the motor, then fix the motor onto the bosses.

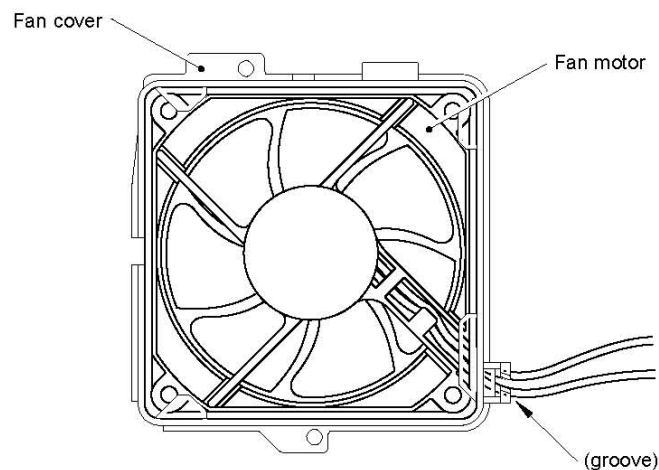

Fig. 4-80

3.19 Toner Sensor PCB ASSY (Light Emission)

NOTE:

Be sure to disconnect the toner sensor (light emission) connector on the engine PCB before removing the toner sensor PCB ASSY (light emission).

- (1) Release the harness from the hooks, then release the hooks of the toner sensor PCB ASSY (light emission) to remove it.

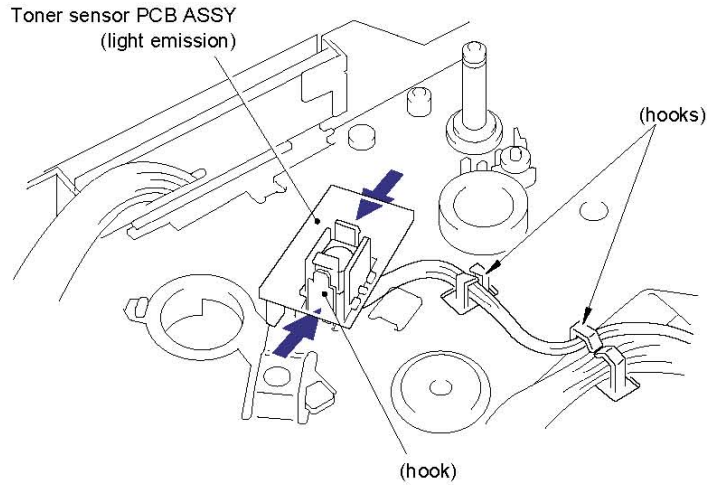

Fig. 4-81

3.20 Toner Sensor PCB ASSY (Light Reception)

NOTE:

Be sure to disconnect the toner sensor (light reception) connector on the engine PCB before removing the toner sensor PCB ASSY (light reception).

- (1) Remove the one M3x6 Taptite screw and release the hooks, then remove the toner sensor PCB ASSY (light reception).

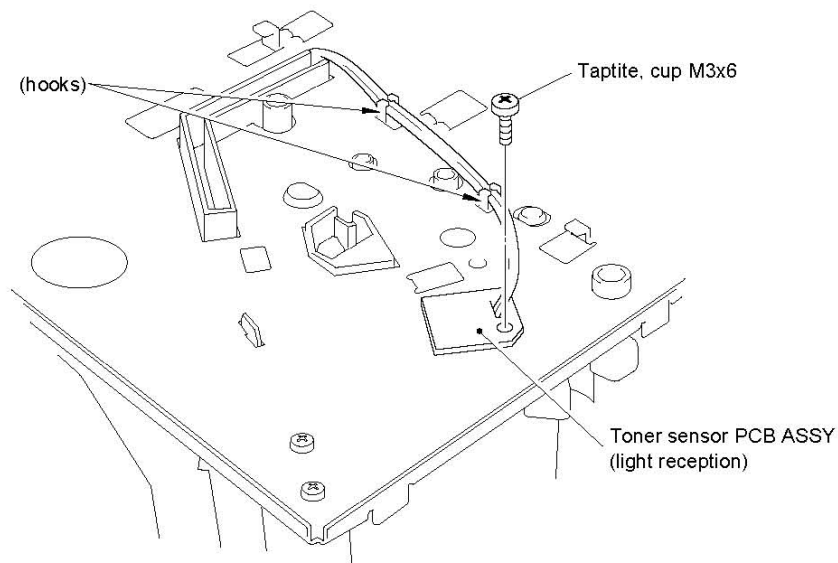

Fig. 4-82

3.21 Paper Pick-up Roller ASSY

NOTE:

Be sure to remove all the covers and the base plate before removing the paper pick-up roller ASSY.

- (1) Place the main frame upside down.
- (2) Unhook the hook to remove the inner gear 54, gear 45 and gear 20 from the main frame.
- (3) Remove the bearing from the paper pick-up roller shaft.
- (4) Release the hook on the bearing at the other side of the shaft and remove the paper pick-up roller ASSY and the shaft from the main frame.

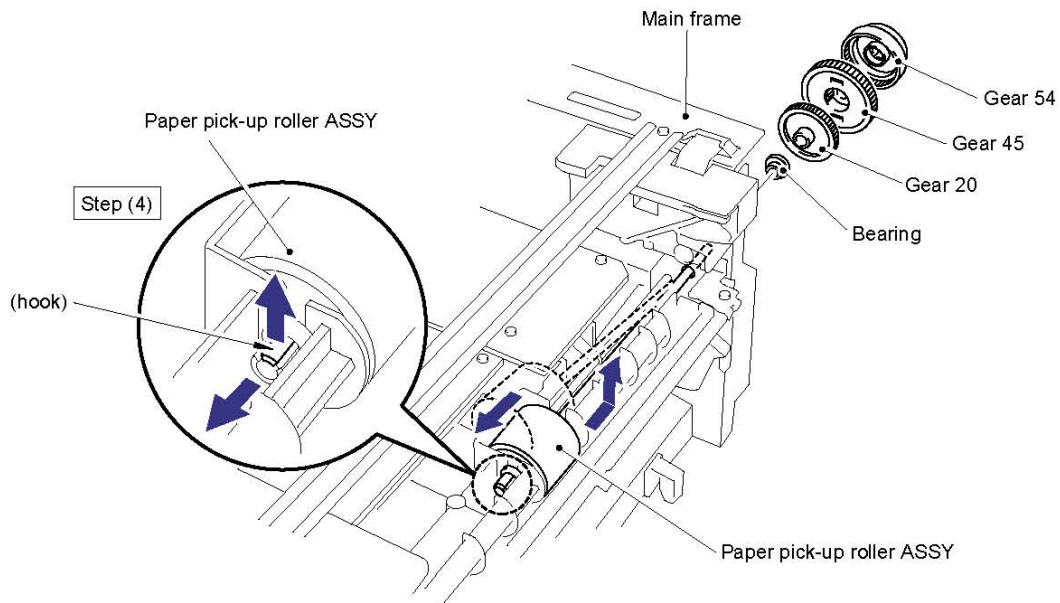

Fig. 4-83

- (5) Remove the bearing and the paper pick-up roller ASSY from the shaft.

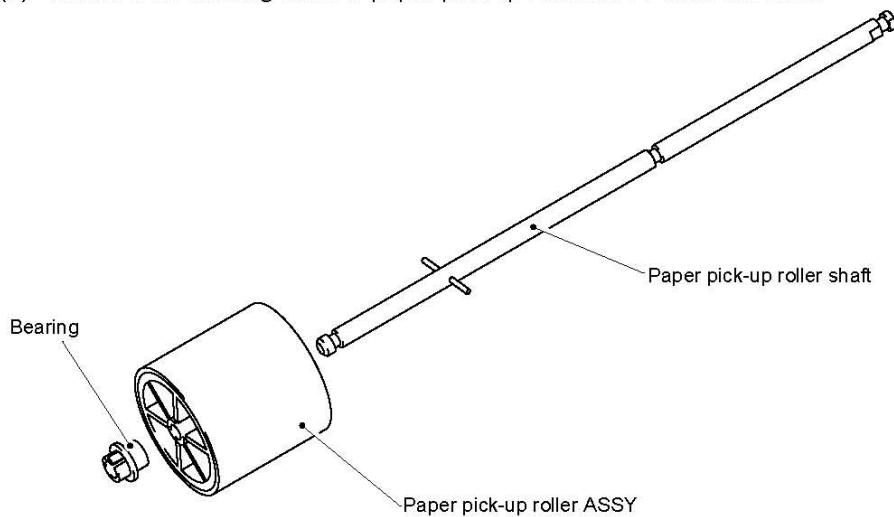

Fig. 4-84

3.22 Paper Feed Roller ASSY

NOTE:

Be sure to remove all the covers and the PCBs before removing the paper feed roller ASSY.

- (1) Unhook the black plastic hook on the shaft to remove gear 21.

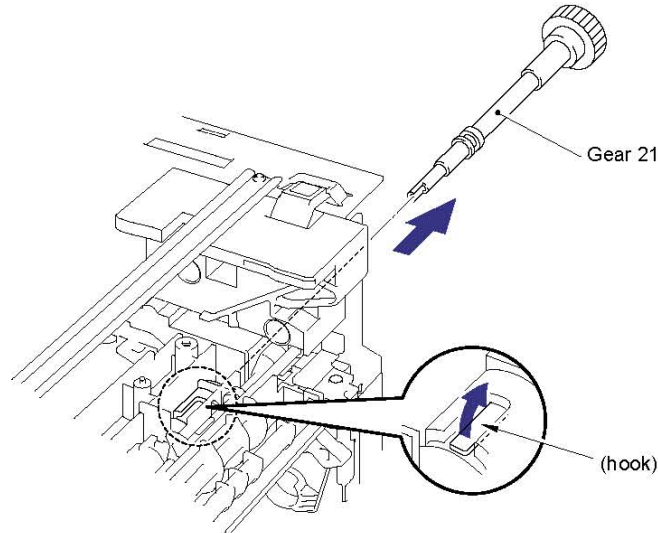

Fig. 4-85

CAUTION:

The plastic hook holding gear 21 will break easily if it is not fully released before the gear is pulled to remove it. Ensure that the hook is fully released BEFORE attempting to remove gear 21.

- (2) Turn the main frame the right way up.
- (3) Unhook the hook on the bearing, then slightly slide the paper feed roller ASSY to the drive unit side.
- (4) Lift up and remove the paper feed roller with the bearing and joint and remove the bearing and joint from the paper feed roller ASSY.

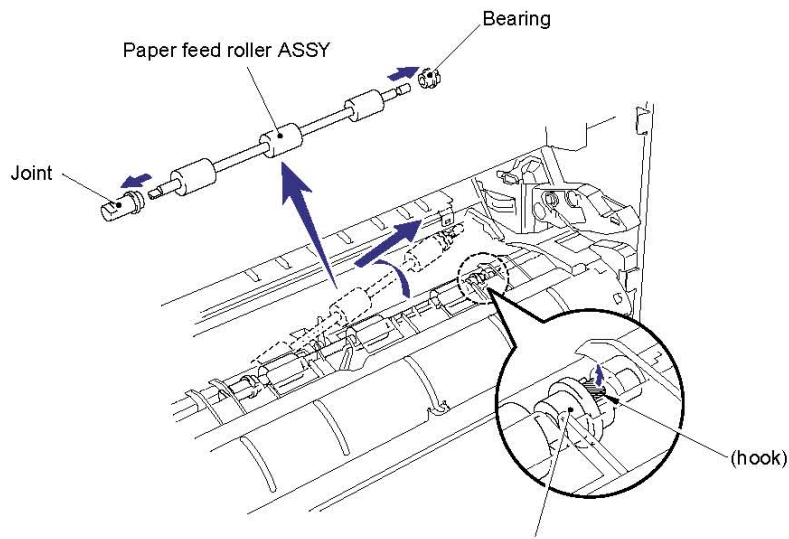

Fig. 4-86

4. GREASE APPLICATION

When replacing/re-assembling the following parts, remove the old grease and apply a suitable amount of grease.

Paper Cassette

<Grease type & amount>
Molykote PG-662
A: 1 sesame size (3 mm³)

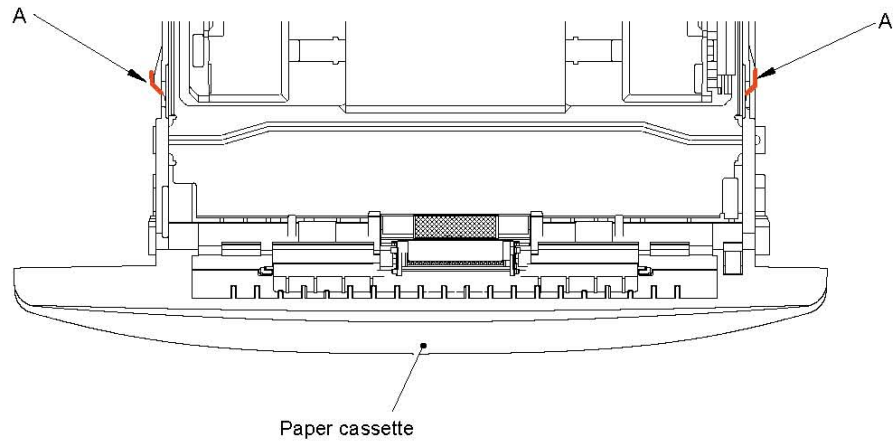

Fig. 4-87

Separation Pad Holder

<Grease type & amount>
Molykote PG-662
A: 1 rice-grain size (6 mm³)

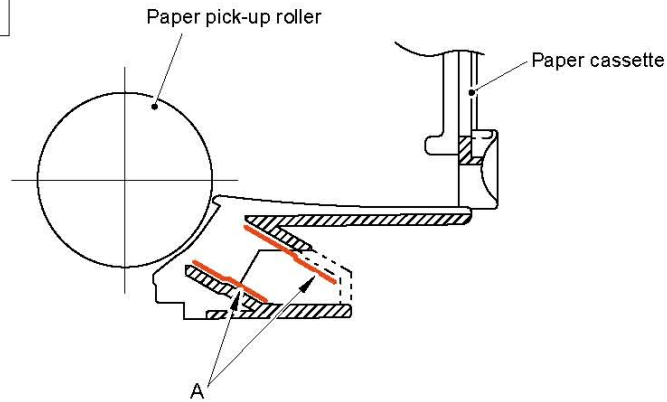

Fig. 4-88

Control Panel ASSY

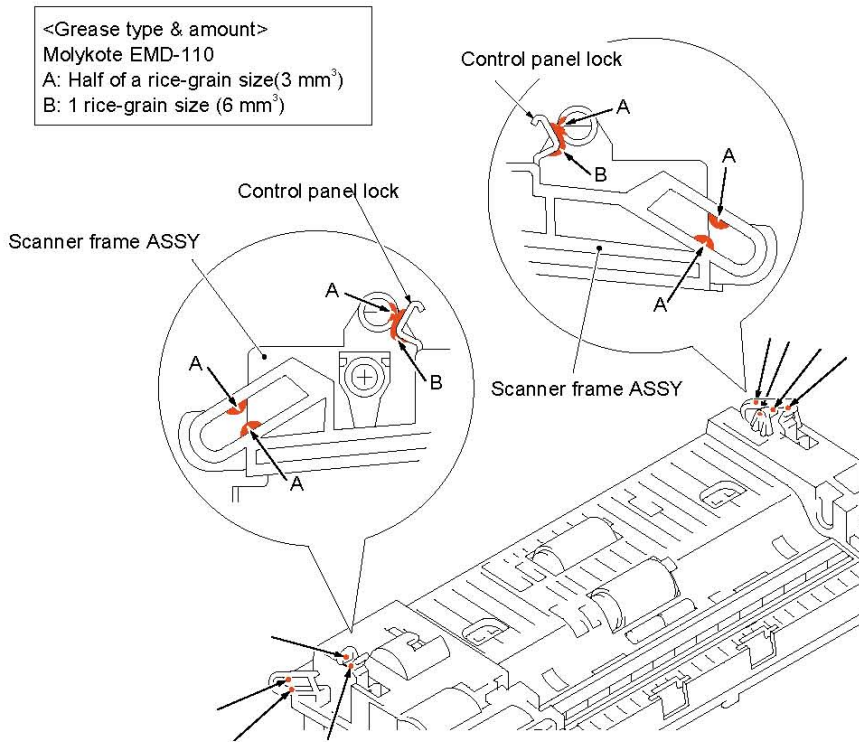

Fig. 4-89

Document Feed Roller ASSY & Document Eject Roller ASSY

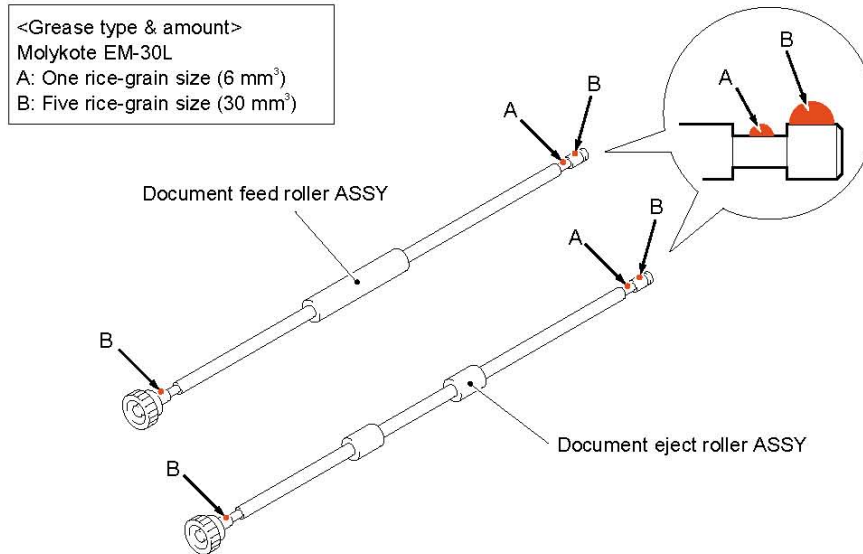

Fig. 4-90

Document Frame ASSY, Document Pick-up Roller & Document Separation Roller

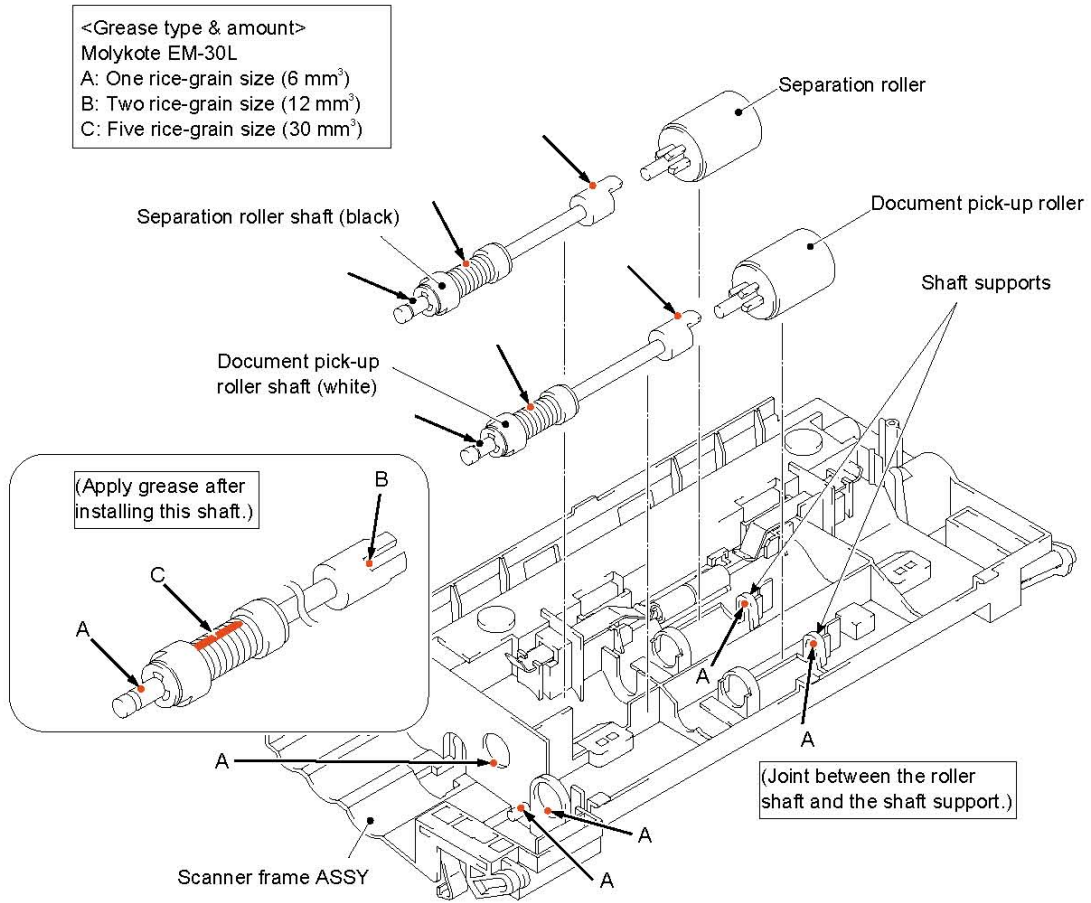

Fig. 4-91

Top Cover & Second Eject Roller

<Grease type & amount>
Molykote EMD-110
A: One rice-grain size (6 mm³)

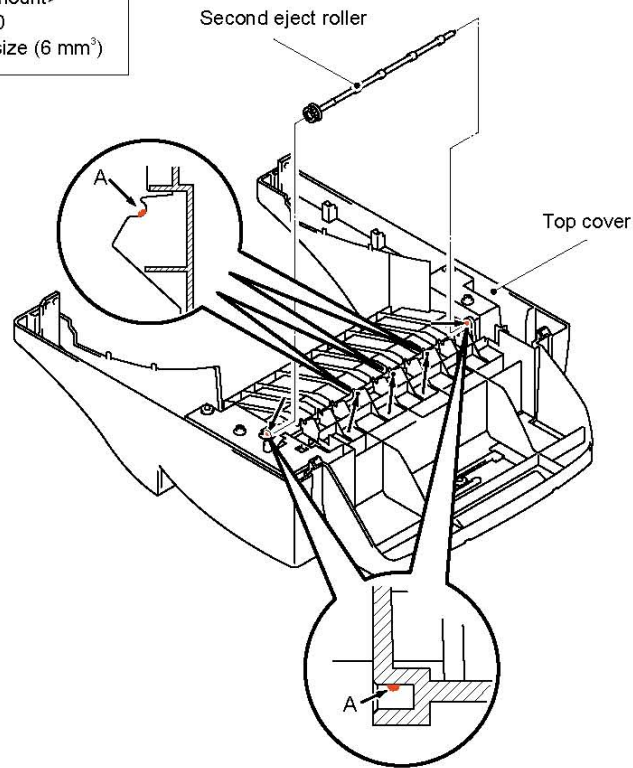

Fig. 4-92

Main Motor

<Grease type & amount>
Molykote PG-662
A: One rice-grain size (6 mm³)

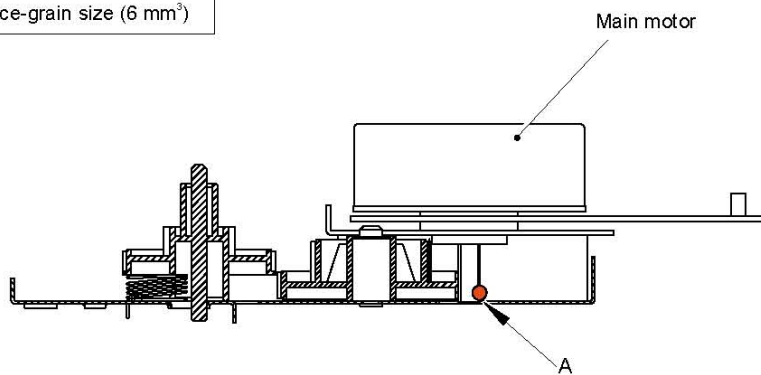

Fig. 4-93

5. PACKING

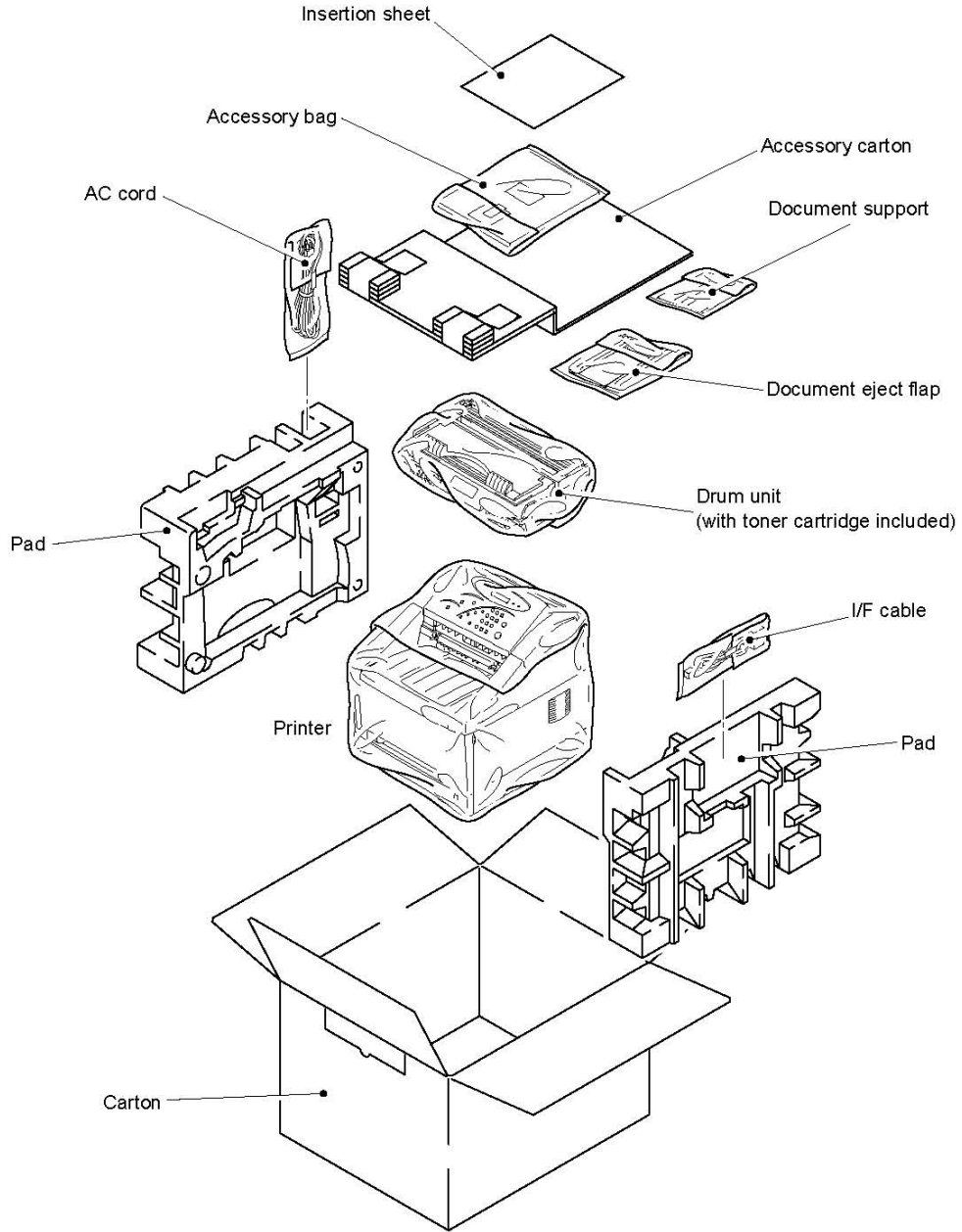

Fig. 4-94

CHAPTER 5 PERIODIC MAINTENANCE

To avoid creating secondary problems by mishandling, follow the warnings below during maintenance work.

WARNING

- (1) Always turn off the power switch and unplug the power cord from the power outlet before accessing any parts inside the printer.
- (2) Some parts inside the printer are extremely hot immediately after the printer is used. When opening the front cover or rear cover to access any parts inside the printer, never touch the red colored parts shown in the following figures.

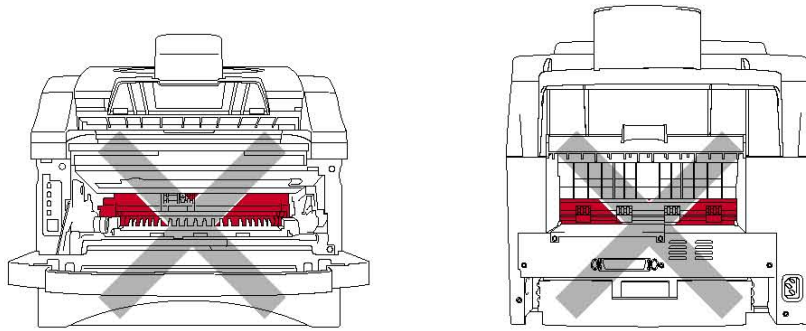

1. CONSUMABLE PARTS

The consumable parts described in this section, that are the parts which subject to deterioration or damage, should be replaced at least once during the period of warranty of the product if any print quality problem appears.

1.1 Drum Unit

The "CHANGE DRUM SOON" message is indicated on the LCD when the drum unit is nearly at the end of its life.

Life expectancy: 20,000 pages

NOTE:

There are many factors that determine the actual drum life, such as temperature, humidity, type of paper, the number of pages per print job, etc.

<Replacement Procedure>

- (1) Open the front cover of the printer and pull out the drum unit.
- (2) Place the drum unit on a flat, horizontal surface and remove the toner cartridge from the drum unit while pushing the lock lever down with your right hand. (Fig. 5-1)
- (3) Unpack the new drum unit.

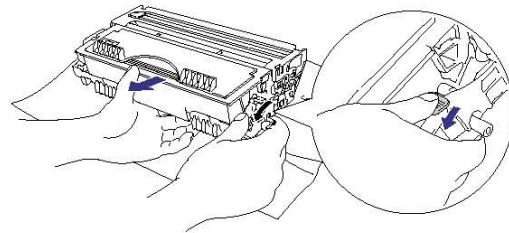

Fig. 5-1

- (4) Install the toner cartridge into the new drum unit until it locks into place, indicated by a click. When the toner cartridge is installed correctly, the lock lever is lifted automatically. (Fig. 5-2)
- (5) Install the new drum unit into the printer.
Check that the printer is turned on and the 'COVER OPEN' message is indicated on the LCD.

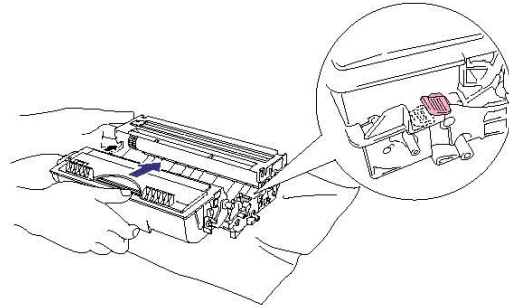

Fig. 5-2

- (6) Press the **Clear** button on the control panel. The 'REPLACE DRUM?' message is indicated on the LCD, then press the **1** key. The drum page counter is now reset.
- (7) Close the front cover and check that the Drum LED is now off.

CAUTION:

- Printing with a 3rd party drum unit or photosensitive drum may reduce not only the printing quality but also the quality and life of the printer itself. Warranty cover is not applied to problems or damage caused by the use of a 3rd party drum unit or photosensitive drum.
- Only unpack a drum unit immediately before you need to install it into the printer. If an unpacked drum unit is subjected to excessive direct sunlight or room light, the unit may be damaged.
- Handle the drum unit and toner cartridge carefully. If toner scatters on your hands or clothes, wipe or wash it off with cold water immediately.
- Do not reset the page counter when replacing the toner cartridge.

1.2 Toner Cartridge

Toner low:	The Toner LED blinks once every second, and the 'TONER LOW' message is indicated on the LCD.
Toner empty:	The Toner LED is ON, and the 'TONER EMPTY' message is indicated on the LCD.
Life expectancy:	3,000 pages/standard toner cartridge 6,000 pages/high-capacity toner cartridge (When printing A4- or Letter-size paper at 5% print coverage)

NOTE:

Toner life expectancy will vary depending on the type of average print job printed.

<Replacement Procedure>

- (1) Open the front cover, and pull out the drum unit from the printer.
- (2) Place the drum unit containing the old toner cartridge on a flat, horizontal surface and remove the toner cartridge from the drum unit while pushing the lock lever down with your right hand.
- (3) Unpack the new toner cartridge and gently rock it from side to side 5 or 6 times keeping it horizontal. (Fig. 5-3)

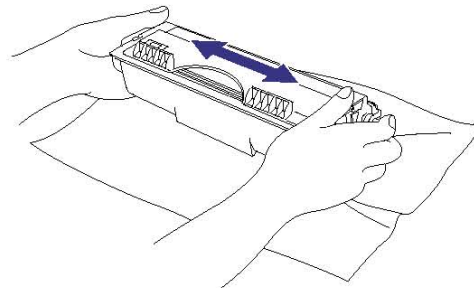

Fig. 5-3

- (4) Remove the protective cover. (Fig. 5-4)
- (5) Install the new toner cartridge into the drum unit until it locks into place, indicated by a click. When the toner cartridge is installed correctly, the lock lever is lifted automatically.

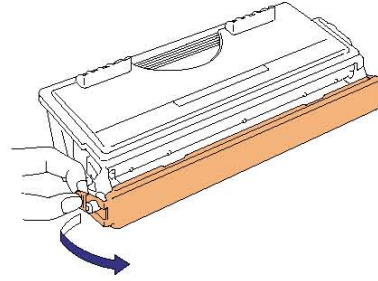

Fig. 5-4

- (6) Clean the primary corona wire inside the drum unit by gently sliding the wire cleaner (blue tab) to the right end and left end several times. (Fig. 5-5)
- (7) Return the cleaner to the home position before re-installing the drum unit.
- (8) Re-install the drum unit into the printer and close the front cover.

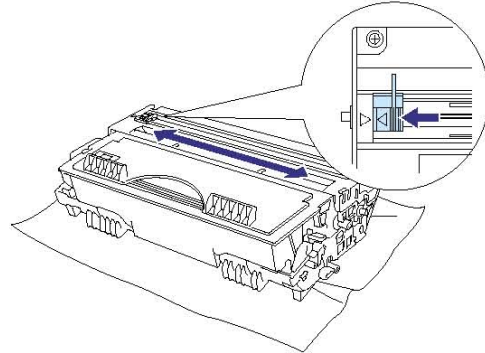

Fig. 5-5

CAUTION:

- Keep the drum unit level after removing the toner cartridge to avoid possible toner spill or scatter.
- Handle the drum unit and toner cartridge carefully. If toner scatters on your hands or clothes, wipe or wash it off with cold water immediately.
- Only unpack a toner cartridge immediately before you need to install it into the printer. If a toner cartridge is left unpacked for a long period of time, the toner life is shortened.
- If an unpacked drum unit is subjected to excessive direct sunlight or room light, the unit may be damaged.
- Use a Brother genuine toner cartridge which is specially formulated to ensure top print quality.
- Printing with a 3rd party toner or toner cartridge may reduce not only the printing quality but also the quality and life of the printer itself. It may also cause serious damage to the performance and life of a genuine Brother drum unit. Warranty cover is not applied to problems caused by the use of 3rd party toner or toner cartridges.
- Make sure that the wire cleaner on the drum unit is returned to the home position (▲ mark position) before re-installing the drum unit into the printer, or printed pages may have vertical stripes. (Refer to Fig. 5-5.)
- Install the toner cartridge immediately after you remove the protective part. Do not touch the development roller and photosensitive drum colored red as shown below;

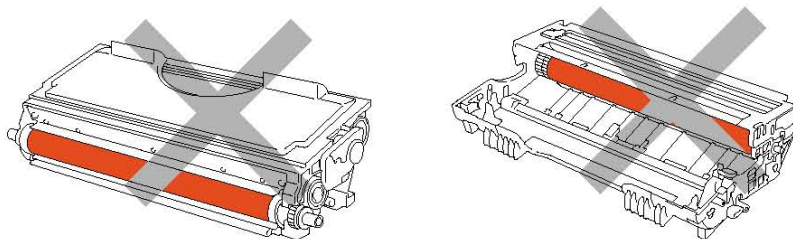

Fig. 5-6

2. PERIODICAL REPLACEMENT PARTS

Periodical replacement parts are the parts to be replaced periodically to maintain product quality at the same level (in other words, parts which would affect the product greatly if they lost their function even if they are not damaged or there is no change in their appearance.)

The periodical replacement parts listed below should be replaced at the service center referring to the service life. For the procedures to replace those parts, refer to [CHAPTER 4 "DISASSEMBLY AND RE-ASSEMBLY"](#).

Parts Name	Part No.	Qty	Service life (number of prints)	Reference Subsection of CHAPTER 4 (Page)
Fixing Unit (120V)	LJ4164001	1	50,000 pages	3.11 (4-27)
Fixing Unit (230V)	LJ4168001	1	50,000 pages	3.11 (4-27)
Separation Pad Holder ASSY	UL9084001	1	50,000 pages	3.3 (4-4)
Pick-up Roller ASSY	UL9066001	1	50,000 pages	3.21 (4-49)
Document Feed Roller	UU2029001	1	50,000 pages	3.5 (4-14)
Separation Rubber	UU2055001	1	50,000 pages	3.4 (4-11)

NOTE:

The above table shows only estimated values. They are subject to change without prior notice.

3. PERIODICAL CLEANING

Clean the following parts periodically to avoid any printer problems or print image defects.

! CAUTION:

While drum unit and scanner window can be basically cleaned by the end user, the electrical terminals inside the printer and on the drum unit should be cleaned by the service technician. Instruct the users not to touch those terminals.

3.1 Clean the Printer Exterior

Clean the printer exterior to keep the printer clean.

- 1) Turn off the power switch and unplug the power cord.
- 2) Wipe dirt and dust away from the printer exterior with a damp cloth and allow the printer to dry completely before turning the power on again.

! CAUTION:

Use water or neutral detergents for cleaning. Cleaning with volatile liquids such as thinners or benzene will damage the surface of the printer.

3.2 Clean the Drum Unit

When replacing the drum unit or toner cartridge with a new one, be sure to clean the drum unit.

- 1) Turn off the power switch and unplug the power cord.
- 2) Remove the drum unit from the printer.
- 3) Clean the primary corona wire inside the drum unit by gently sliding the wire cleaner (blue tab) to the right end and left end several times.

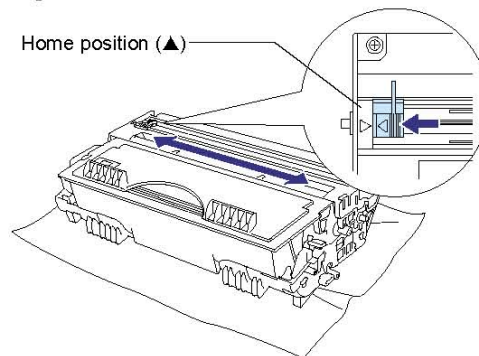

Fig. 5-7

- 4) Return the cleaner to the home position.

! CAUTION:

Make sure that the wire cleaner on the drum unit is returned to the home position (▲ mark position) before re-installing the drum unit into the printer, or printed pages may have vertical stripes.

3.3 Clean the Scanner Window

When replacing the drum unit or toner cartridge with a new one, be sure to clean the scanner window.

- 1) Turn off the power switch and unplug the power cord.
- 2) Remove the drum unit from the printer.
- 3) Gently wipe the scanner window (colored magenta in the figures below) with a soft dry cloth.

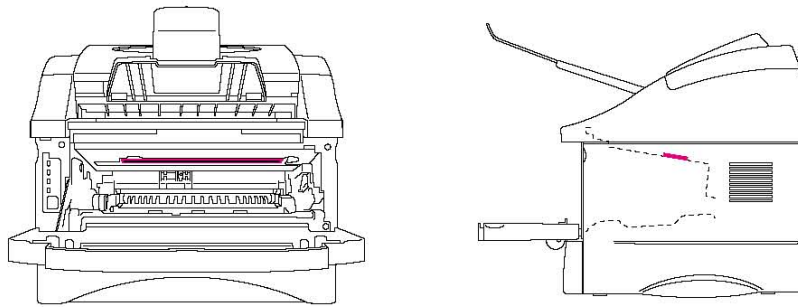

Fig. 5-8

! CAUTION:

- Do not touch the scanner window with your fingers.
- Do not wipe the scanner window with cleaning alcohol (isopropyl).

3.4 Clean the Electrical Terminals

When replacing the drum unit or toner cartridge with a new one, be sure to clean the electrical terminals inside the printer body.

- 1) Turn off the power switch and unplug the power cord.
- 2) Remove the drum unit from the printer.
- 3) Wipe the electrical terminals as shown in the figure below with a soft dry cloth.

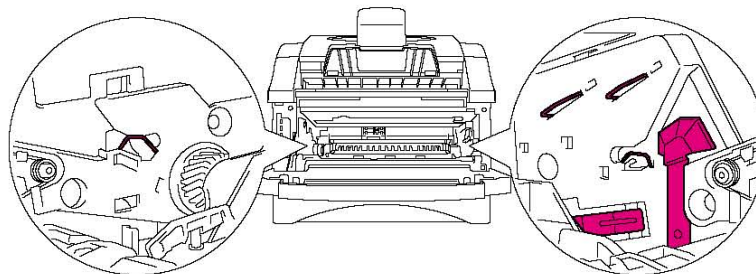

Fig. 5-9

3.5 Clean the Scanning Unit

Clean the scanning unit if marks appear on the copied document.

- 1) Turn off the power switch and unplug the power cord.
- 2) Open the control panel cover.
- 3) Clean the flat white pressure bar and the glass scanner cover under the bar. Moisten a small, clean, soft, lint-free cloth with isopropyl alcohol and carefully remove dirt from the white pressure bar and the glass cover.

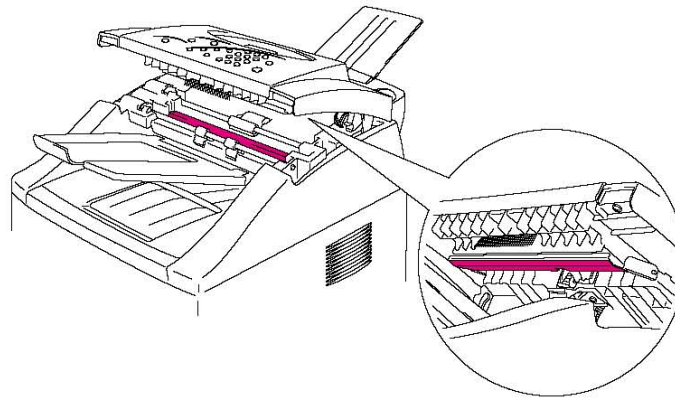

Fig. 5-10

4. MTBF / MTTR

The meantime between failure (MTBF) and the meantime to repair (MTTR) for this printer are as follows;

MTBF: Up to 4,000 hours

MTTR: Average 30 minutes

CHAPTER6 MAINTENANCE MODE

1. TEST PRINT MODE

The printer incorporates various test print modes.

Select the test mode you want to use following the steps below;

- (1) Turn off the power switch of the printer and check that the front cover is closed.
- (2) Turn on the power switch while holding down the **Job Cancel** button. The following messages are indicated alternately on the LCD.
1. TEST PRINT → 2. PRINT CONFIG → 3. PRINT FONTS → 4. HEX DUMP → 5. FACTORY RESET → 6. DRUM LIFE
- (3) If you want to execute the test print, press the **1** key.

If you want to execute another option, hold down the specified key in the 10 keys to select it as shown in the table below. Release and then press the button to execute the selected option.

10 Key	Type of mode	Function
1	TEST PRINT	The printer prints a test sample page. The printer returns to the ready status after printing.
2	PRINT CONFIG	The printer prints the current configuration of the printer. The printer returns to the ready status after printing.
3	PRINT FONTS	The printer prints a list of the internal fonts. The printer returns to the ready status after printing.
4	HEX DUMP	The printer can print data as hexadecimal values so that you can check data errors and problems. To exit from this mode, you have to turn off the printer.
5	FACTORY RESET	The printer is restored to the factory setting, and the printer power switch is turned on.
6	DRUM LIFE	The printer indicates the remaining drum life.

CAUTION:

'TEST PRINT' in the table above cannot be implemented if the paper size is set to the smaller size than A4/Letter. Make sure to set the paper size to A4 or Letter by pressing the **Paper size** button.

Demo printer operation

To print the demo page, you can implement one of the following procedures;

- Press the **Copy** button while pressing the **Stop** button in ready status.
- Enter the test print mode by following the procedure above, then select '1. TEST PRINT'.

NOTE:

The demo printer never return to being a normal printer even after it receives data from a PC.

2. MAINTENANCE MODE

The printer incorporates various maintenance functions which can check or test the printer performance.

Enter the maintenance mode following the steps below;

- (1) Turn off the power switch of the printer.
- (2) Turn on the power switch while pressing the **Job Cancel** button and **1** key.
- (3) The printer displays “■■ MAINTENANCE ■ 7 ■” on the LCD, indicating that it is in the initial stage of the maintenance mode, a mode in which the printer is ready to accept entry from the keys.
- (4) Enter the corresponding 2-digit function code with the specified 10 keys on the control panel to select one of the maintenance mode functions listed below; (The details on each maintenance mode function are described in the following sections.)

NOTE:

- If you press the **9** key twice in the initial stage of the maintenance mode, the printer exits from the maintenance mode and returns to the ready status.
- If you press the **Stop** button after entering only one digit, the printer returns to the initial stage of the maintenance mode.
- If an invalid function code is entered, the printer remains in the initial stage of the maintenance mode.

Function Code	Function	Reference Subsection (Page)
01	EEPROM Parameter Initialization	2.1 (6-3)
05	Printout of Scanning Compensation Data	2.2 (6-3)
08	ADF (Automatic Document Feeder) Performance Test	2.3 (6-5)
09	Test Pattern 1	2.4 (6-5)
12	Operational Check of LCD	2.5 (6-6)
13	Operational Check of Control Panel PCB (Check of Keys and Buttons)	2.6 (6-6)
32	Sensor Operational Check	2.7 (6-7)
55	CIS Scanner Area Setting	2.8 (6-8)
74	EEPROM Customizing	2.9 (6-8)
82	Equipment Error Code Indication	2.10 (6-9)
99	Exit from the maintenance mode	---- (6-2)

2.1 EEPROM Parameter Initialization

Function

The printer initializes the parameters, user switches and firmware switches registered in the EEPROM to the initial value. Entering the function code 01 initializes all of the EEPROM areas as listed below;

- ✍ User switches
- ✍ Firmware switches

NOTE:

- *EEPROM customizing code (4-digit) will NOT be initialized. Note that the first digit of the 4-digit code will be initialized to "0". If the code is 1001, for example, it will be initialized to 0001.*
- *If you replace the main PCB with one used for other printer, implement this procedure and then customize the EEPROM (maintenance mode function code 74 in [Subsection 2.9.](#))*

Operating Procedure

- (1) Press the **0** and **1** keys in this order in the initial stage of the maintenance mode.
- (2) When parameter initialization is completed, the printer returns to the initial stage of the maintenance mode.

2.2 Printout of Scanning Compensation Data

Function

The printer prints the white and black level data for scanning compensation.

Operating Procedure

Do not start this function just after turning on the printer, only start it after implementing a scanning operation. Unless the printer has implemented a scanning operation, this function cannot print out the correct scanning compensation data. This is because at the start of a scanning operation, the printer initializes the white and black level data and takes in the scanning compensation reference data.

- (1) Press the **0** and **5** keys in this order in the initial stage of the maintenance mode.
The "WHITE LEVEL 1" message will appear on the LCD.
- (2) The printer prints the scanning compensation data list containing the following items;
 - a) 2-value quantization white level data (2496 bytes)
 - b) 2-value quantization black level data (1 byte)
 - c) LED light intensity value, 2-value quantization LED light intensity value, and photo mode LED light intensity value (3 bytes)
 - d) 2-value quantization A/D-high and photo-mode A/D-high values (2 bytes)
 - e) A/D-low value (1 byte)
 - f) Compensation data for background color (1 byte)
- (3) When the compensation data list recording is completed, the printer returns to the initial stage of the maintenance mode.

NOTE:

- *When the printer prints monochrome images after monochrome scanning, only the green data is valid.*
- *If any data is abnormal, its code will be printed in inline style, as shown on the next page.*

9A90	:	77	73	73	70	6D	70	77	77	73	70	73	6C	72	70	73	77
9AA0	:	70	77	68	69	70	6A	72	6A	69	67	64	65	67	68	6D	67
9AB0	:	67	65	64	65	60	68	62	64	64	60	64	65	61	64	64	60
9AC0	:	67	65	6A	67	67	67	61	61	6F	6E	6E	64	64	64	67	60
9AD0	:	69	6D	61	62	6D	64	64	64	6C	6C	6C	6D	68	67	65	60
9AE0	:	61	61	62	62	67	67	6C	64	65	65	65	6D	68	67	65	60
9AF0	:	65	65	6A	6A	6C	6C	6C	6A	67	6A	6A	65	65	65	62	64
9B00	:	65	6A	65	6D	70	6A	6A	6A	6C	73	73	70	6D	65	6C	6C
9B10	:	6C	70	6F	70	65	6C	6A	6D	6A	6D	6A	6A	68	68	67	65
9B20	:	66	67	6F	67	61	67	67	65	65	64	64	66	68	67	61	61
9B30	:	66	66	6F	67	6C	67	65	65	65	66	66	66	66	67	67	64
9B40	:	67	67	62	68	6D	67	64	64	66	66	66	66	66	66	61	64
9B50	:	61	61	6D	6D	6D	61	67	67	67	67	62	62	65	68	67	62
9B60	:	67	67	64	68	72	6C	67	68	67	67	67	6D	6A	65	67	67
9B70	:	67	64	67	67	64	67	6A	67	68	67	6D	6A	6C	67	68	6C
9B80	:	65	67	68	70	73	64	6D	68	6A	6D	6D	70	70	70	6C	6F
9B90	:	6A	6D	6C	6D	65	6A	6A	63	65	64	65	61	64	6D	6D	64
9BA0	:	6A	6E	6E	6E	6E	6E	6E	6E	6E	6E	6E	6E	6E	6E	6E	6E
9BB0	:	4E	4E	4E	4E	4E	4E	4E	4E	4E	4E	4E	4E	4E	4E	4E	4E
9BC0	:	2E	2E	2E	2E	2E	2E	2E	2E	2E	2E	2E	2E	2E	2E	2E	2E
9BD0	:	1E	1E	1E	1E	1E	1E	1E	1E	1E	1E	1E	1E	1E	1E	1E	1E
9BE0	:	1E	1E	1E	1E	1E	1E	1E	1E	1E	1E	1E	1E	1E	1E	1E	1E
9BF0	:	1E	1E	1E	1E	1E	1E	1E	1E	1E	1E	1E	1E	1E	1E	1E	1E
9C00	:	1E	1E	1E	1E	1E	1E	1E	1E	1E	1E	1E	1E	1E	1E	1E	1E
9C10	:	1E	1E	1E	1E	1E	1E	1E	1E	1E	1E	1E	1E	1E	1E	1E	1E
9C20	:	1E	1E	1E	1E	1E	1E	1E	1E	1E	1E	1E	1E	1E	1E	1E	1E
9C30	:	1E	1E	1E	1E	1E	1E	1E	1E	1E	1E	1E	1E	1E	1E	1E	1E
9C40	:	0E	0E	0E	0E	0E	0E	0E	0E	0E	0E	0E	0E	0E	0E	0E	0E
9C50	:	FF	FF	FF	FF	FF	FF	FF	FF	FF	FF	FF	FF	FF	FF	FF	FF
9C60	:	1E	1E	1E	1E	1E	1E	1E	1E	1E	1E	1E	1E	1E	1E	1E	1E
9C70	:	0E	0E	0E	0E	0E	0E	0E	0E	0E	0E	0E	0E	0E	0E	0E	0E
9C80	:	0E	0E	0E	1E	1E	1E	1E	1E	1E	1E	1E	1E	1E	1E	1E	1E
9C90	:	1E	1E	1E	1E	1E	1E	1E	1E	1E	1E	1E	1E	1E	1E	1E	1E
9CA0	:	1E	1E	1E	1E	1E	1E	1E	1E	1E	1E	1E	1E	1E	1E	1E	1E
9CB0	:	1E	1E	1E	0E	0E	0E	0E	0E	0E	0E	0E	0E	0E	0E	0E	0E
9CC0	:	0E	0E	0E	0E	0E	0E	0E	0E	0E	0E	0E	0E	0E	0E	0E	0E
9CD0	:	FF	FF	FF	FF	FF	FF	FF	FF	FF	FF	FF	FF	FF	FF	FF	FF
9CE0	:	1E	1E	1E	1E	1E	1E	1E	1E	1E	1E	1E	1E	1E	1E	1E	1E
9CF0	:	1E	1E	1E	1E	1E	1E	1E	1E	1E	1E	1E	1E	1E	1E	1E	1E
9D00	:	1E	1E	1E	1E	1E	1E	1E	1E	1E	1E	1E	1E	1E	1E	1E	1E
9D10	:	1E	1E	1E	1E	1E	1E	1E	1E	1E	1E	1E	1E	1E	1E	1E	1E
9D20	:	1D	1E	1E	1E	1E	1E	1E	1E	1E	1E	1E	1E	1E	1E	1E	1E
9D30	:	1E	1E	1E	1E	1E	1E	1E	1E	1E	1E	1E	1E	1E	1E	1E	1E
9D40	:	1E	1E	1E	1E	1E	1E	1E	1E	1E	1E	1E	1E	1E	1E	1E	1E
9D50	:	1E	1E	1E	1E	1E	1E	1E	1E	1E	1E	1E	1E	1E	1E	1E	1E
9D60	:	1E	1E	1E	1E	1E	1E	1E	1E	1E	1E	1E	1E	1E	1E	1E	1E
9D70	:	1E	1E	1E	1E	1E	1E	1E	1E	1E	1E	1E	1E	1E	1E	1E	1E
9D80	:	2E	2E	2E	2E	2E	2E	2E	2E	2E	2E	2E	2E	2E	2E	2E	2E
9D90	:	2E	2E	2E	2E	2E	2E	2E	2E	2E	2E	2E	2E	2E	2E	2E	2E
9DA0	:	6E	6E	6E	6E	6E	6E	6E	6E	6E	6E	6E	6E	6E	6E	6E	6E
9DB0	:	6C	6A	6A	68	62	67	67	6A	6C	70	70	6D	6D	6D	6F	70
9DC0	:	6D	73	7A	6A	65	62	62	67	68	6D	6D	6D	6D	6D	6A	6A
9DD0	:	6A	6D	6D	6C	67	70	6F	73	70	6F	70	6C	6F	70	70	73
9DE0	:	73	73	73	70	73	73	73	77	77	75	78	80	7D	7B	7B	7B
9DF0	:	7B	7D	77	78	78	82	82	83	7D	7D	80	82	80	82	86	80
9E00	:	85	85	83	90	93	96	93	92	93	93	92	92	96	99	95	96
9E10	:	98	93	95	96	96	9B	96	96	96	93	96	98	99	99	95	98
9E20	:	96	93	98	96	A0	93	98	93	93	92	93	9D	96	93	93	96
9E30	:	90	93	96	93	90	92	90	8D	8E	8E	90	93	90	8E	8D	86
9E40	:	86	88	93	80	80	82	7D	78	7D	75	7A	7B	77	7D	7A	7A
9E50	:	7F	82	83	83	82	83	83	86	95	8B	8A	86	86	83	83	88
9E60	:	83	8B	86	88	8E	85	86	88	95	8B	8D	8A	8E	8B	8D	8B
9E70	:	92	95	8A	8E	86	90	90	90	93	92	90	92	92	92	96	95
9E80	:	96	99	95	A0	99	9E	9E	A1	A9	9D	A3	A0	A0	A6	A9	AB
9E90	:	A8	A6	A6	A3	A0	A6	A4	A9	A6	A3	A8	A1	A9	A8	AB	AC
9EA0	:	A9	AC	A9	AC	A9	AC	AB	AB	A5	A3	A3	A6	A6	A8	AC	A6
9EB0	:	A9	A0	A1	A3	A0	A6	A0	9D	A0	9D	9B	9D	A0	A1	A6	9D
9EC0	:	A1	9E	A4	9E	9E	9D	98	9D	93	92	92	90	96	98	98	95
9ED0	:	95	98	A0	A0	9D	9D	A3	9D	9B	9D	A0	A3	A4	9B	A3	A0
9EE0	:	A1	A3	A6	A9	AB	9D	A3	A0	A4	A9	A8	B0	A8	AB	A3	A1
9EF0	:	A4	A8	A4	A9	9E	A8	A1	A6	A3	A3	A6	A3	A0	A3	9B	A1
9F00	:	A8	A0	A6	A9	A9	A3	A3	A9	A6	AB	A9	A3	A6	A0	A6	A9
9F10	:	A6	AB	A6	A3	9E	9E	A1	9E	A6	A9	A1	A3	A0	9D	A0	A3
9F20	:	A4	A6	9E	9E	A1	A3	A3	A1	A3	A0	A0	A6	9D	A3	A0	A6
9F30	:	A8	A3	A4	A3	9E	A3	A3	A3	A6	A1	A0	9D	9B	A1	9D	A1
9F40	:	A0	9D	A6	80	8A	86	8E	92	8A	80	80	83	86	82	85	8B
9F50	:	86	86	83	88	83	90	90	8B	8A	8A	8D	8A	90	95	93	93
9F60	:	98	8E	8B	96	99	9D	99	92	95	92	96	9D	9D	A0	99	9B
9F70	:	99	96	95	93	93	9E	96	96	92	95	96	98	9D	99	9B	98
9F80	:	99	99	99	A6	A4	9E	9D	9D	9E	A0	A3	A8	A4	A0	A1	99
A420	:	A3	A3	9E	A3	AB	A1	9D	92	99	93	93	98	99	93	93	93
A430	:	86	80	86	85	83	83	77	7B	7A	73	72	77	75	6D	68	6E
A440	:	6E	6A	70	FF	FF	FF	FF	FF	FF	FF	FF	FF	FF	FF	FF	FF
9A90	:	1F															
9A90	:	00															

Fig. 6-1

2.3 ADF Performance Test

Function

The printer counts the documents fed by the automatic document feeder (ADF) and displays the count on the LCD for checking the ADF performance.

Operating Procedure

- (1) Set documents. (Allowable quantity = up to the ADF capacity.)
The "DOC. READY" message will appear on the LCD.
- (2) Press the **0** and **8** keys in this order.
While counting the documents, the printer feeds them in and out, displaying the current count on the LCD as shown below;

ADF CHECK P.01

— Current count (1st page in this example)

- (3) Press the **Stop** button so that the printer returns to the initial stage of the maintenance mode.

2.4 Test Pattern 1

Function

This function, much like the copying function, prints out test pattern 1 so that service personnel can check for recording data missing or print quality.

Operating Procedure

Press the **0** and **9** keys in this order in the initial stage of the maintenance mode.
The figure below shows test pattern 1.

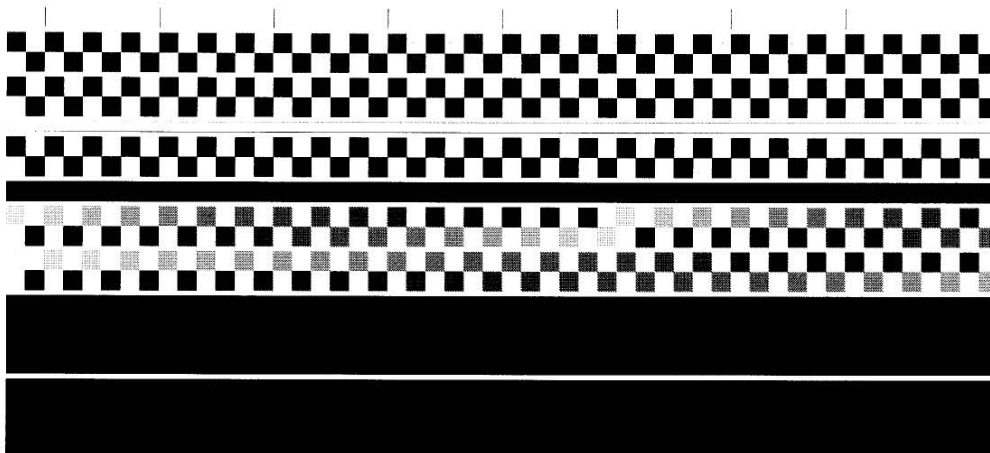

Fig. 6-2

2.5 Operational Check of LCD

Function

This function allows you to check whether the LCD on the control panel works normally.

Operating Procedure

- (1) Press the **1** and **2** keys in this order in the initial stage of the maintenance mode.
- (2) The LCD shows (A) shown at right.

Press the **Options** button. Each time you press the **Options** button, the LCD cycles through the displays shown at right.

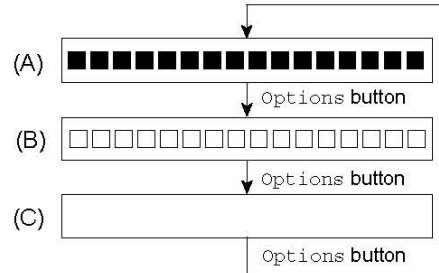

- (3) Press the **Stop** button in any process of the above display cycle. The printer returns to the initial stage of the maintenance mode.

2.6 Operational Check of Control Panel PCB

Function

This function allows you to check the control panel PCB for normal operation.

Operating Procedure

- (1) Press the **1** and **3** keys in this order in the initial stage of the maintenance mode. The "00" will appear on the LCD.
- (2) Press the keys and buttons in the sequence shown in the illustration below; The LCD shows the corresponding number in decimal notation each time a key or button is pressed. Check that the displayed number is correct by referring to the figure below; If a key or button is pressed out of order, the printer displays the "INVALID OPERATE" message on the LCD. Press the **Stop** button so that the printer returns to the ready status to accept key & button entry again for the operational check.

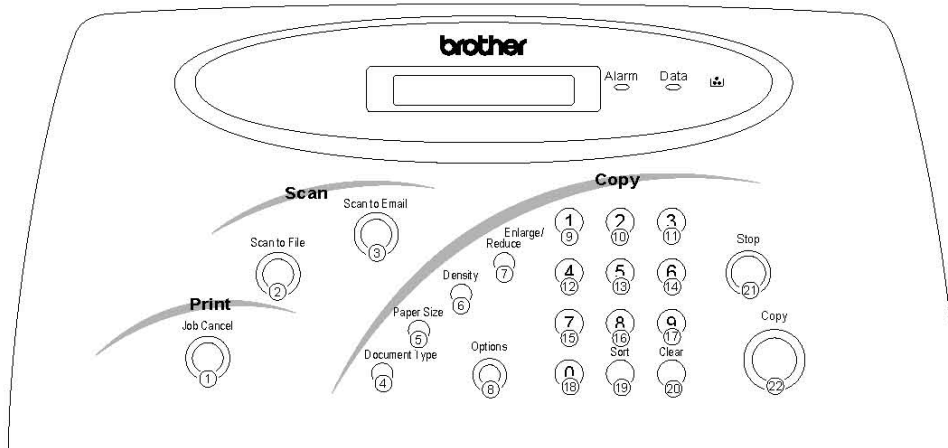

Fig. 6-3

- (3) After the last number key or button is pressed, the printer returns to the initial stage of the maintenance mode.

If you press the **Stop** button, this operation is terminated, and the printer returns to the initial stage of the maintenance mode.

2.7 Sensor Operational Check

Function

This function allows you to check whether the eight sensors – document front sensor, document rear sensor, cover sensor, registration sensor, toner sensor, paper eject sensor, manual feed sensor and cassette sensor – operate correctly.

Operating Procedure

- (1) Press the **3** and **2** keys in this order in the initial stage of the maintenance mode. If the sensor status conditions are as listed below, the LCD will show the following message;
- US model: "DFDRCVRSTNPOHKR2" ("MNCSC2" if you press the **Options** button)
 - Europe model: "DFDRCVRSTNPO R2" ("MNCSC2" if you press the **Options** button)

LCD indication	Sensor	Sensing status
DF	Document front sensor	No document is detected.
DR	Document rear sensor	No document is detected.
CV	Cover sensor	Front cover is closed.
RS	Registration sensor	No paper is detected.
TN	Toner sensor	No toner is detected.
PO	Paper eject sensor	No paper is jammed.
HK	Type of Main PCB	Identify US or Europe model.
R2	Lower paper cassette registration sensor	No paper is detected.
MN	Manual insertion sensor	No paper is detected.
CS	Upper Paper cassette sensor	No paper cassette is installed.
C2	Lower paper cassette sensor	No paper cassette is installed.

- (2) Change the detecting conditions (e.g., insert paper through the document sensors or the registration sensor, open the front cover, remove the toner cartridge, jam paper at the paper outlet, lift up the handset, insert paper manually through the paper slot and load the paper cassette), then check that the indication on the LCD changes according to the sensor state.
- (3) Press the **Stop** button so that the printer returns to the initial stage of the maintenance mode.

2.8 CIS Scanner Area Setting

Function

This printer checks the CIS scanner area.

Operating Procedure

- (1) Press the **5** key twice in the initial stage of the maintenance mode.
The "SCANNER AREA SET" will appear on the LCD.
- (2) The printer checks and sets the area to be scanned.
- (3) If no error is noted, the printer returns to the initial stage of the maintenance mode.
If any error is noted, the "SCANNER ERROR" message will appear on the LCD. Press the **Stop** button so that the printer returns to the initial stage of the maintenance mode.

CAUTION:

*This maintenance function cannot be implemented if the paper size is set to the smaller size than A4/Letter. Make sure to set the paper size to A4 or Letter by pressing the **Paper size** button.*

2.9 EEPROM Customizing

Function

This function allows you to customize the EEPROM according to language, function settings, and firmware switch settings. The customizing codes list is given below;

NOTE:

If you replace the main PCB, be sure to implement this procedure.

Operating Procedure

- (1) Press the **7** and **4** keys in this order in the initial stage of the maintenance mode.
The current customizing code appears.
- (2) Enter the desired customizing code. The newly entered code appears.

NOTE:

If a wrong 4-digit code is entered, the printer will malfunction.

- (3) Press the **Options** button.
The printer saves the setting and returns to the initial stage of the maintenance mode.
If you press the **Stop** button or no buttons are pressed for one minute in the above procedure, the printer stops the procedure and returns to the initial stage of the maintenance mode.

Country	Customizing code
U.S.A.	0001
Canada	0002
Germany	0003
U.K.	0004
France	0005
Australia	0006
Norway	0007
Belgium	0008
Netherlands	0009
Switzerland	0010
Ireland	0011
Finland	0012
Denmark	0013
Austria	0014
Spain	0015

Country	Customizing code
Italy	0016
Israel	0017
Portugal	0018
South Africa	0024
Sweden	0026
New Zealand	0027
Chili	0036
Czech	0037
Hungary	0038
Poland	0039
Singapore	0040
Gulf	0041
Brazil	0042
India	0045
Mexico	0046

2.10 Printer Error Code Indication

Function

This function displays the error code of the last error on the LCD.

Operating Procedure

- (1) Press the **8** and **2** keys in this order in the initial stage of the maintenance mode.
The LCD shows the "MACHINE ERROR X X".
- (2) Press the **Stop** button so that the printer returns to the initial stage of the maintenance mode.

CHAPTER 7 TROUBLESHOOTING

1. INTRODUCTION

1.1 Initial Check

(1) Operating environment

Check if :

- The source voltage stays within $\pm 10\%$ from the rated voltage shown on the rating plate.
- The printer is installed on a solid, level surface.
- The room temperature is maintained between 10°C and 32.5°C. The relative humidity is maintained between 20% and 80%.
- The printer is not located in a dusty place.
- The printer is not exposed to ammonia fumes or other harmful gases.
- The printer is not located in a hot or humid area (such as near water or a humidifier).
- The printer is not exposed to direct sunlight.
- The room is well-ventilated.
- The printer is not placed where the ventilation hole in the printer is blocked.

(2) Print paper

Check if :

- A recommended type in print paper is being used. [If the paper is too thick or too thin, or tends to curl, paper jams or paper feed problems may occur, or printed images may be blurred.]
- The print paper is damp. [If so, use fresh paper, and check whether the print quality improves or not.]
- The print paper is short-grained paper or acid paper. [If so, print quality problems may occur.]

For further information on paper, refer to [subsection 3.6 'Paper' in CHAPTER 1](#).

(3) Consumable parts

Check if :

- The Toner LED is not lit on the printer control panel when a toner cartridge is installed in the printer. [If the LED is lit, replace the cartridge with a new one.]

For further information on consumable parts, refer to [Section 1 'Consumable Parts' in CHAPTER 5](#).

(4) Others

Condensation:

When the printer is moved from a cold room into a warm room in cold weather, condensation may occur inside the printer, causing various problems as listed below:

- Condensation on the optical surfaces such as the scanning mirror, lenses, the reflection mirror and the protection glass may cause the print image to be light.
- If the photosensitive drum is cold, the electrical resistance in the photosensitive layer is increased, making it impossible to obtain the correct contrast when printing.

- Condensation on the corona unit may cause corona charge leakage.
- Condensation on the hopper plate and separation pad may cause paper feed problems.

If condensation has occurred, print several pages or leave the printer for 2 hours to allow it to reach room temperature.

If the drum unit is unpacked soon after it is moved from a cold room to a warm room, condensation may occur inside the unit, which may cause incorrect images. Instruct the user to allow the unit to come to room temperature before unpacking it. This will take one or two hours.

1.2 Warnings during Maintenance

To avoid creating secondary problems by mishandling, follow the warnings below during maintenance work.

 **WARNING**

(1) Always turn OFF the power switch and unplug the power cord from the power outlet before accessing any parts inside the printer.

(2) Some parts inside the printer are extremely hot immediately after the printer is used. When opening the front cover or rear cover to access any parts inside the printer, never touch the red colored parts shown in the following figures.

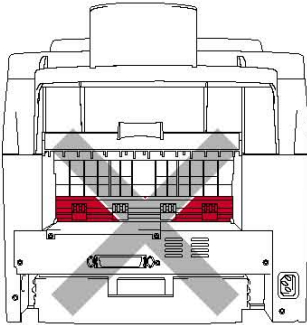
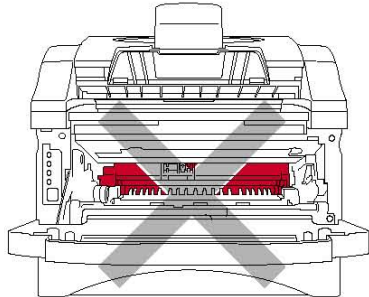

1.3 Identify the Problem

If you encounter any printer error or problem, first identify it referring to the chart below, then see the appropriate section.

NOTE:

The following troubleshooting sections contain both the actions which users should take or check and the ones which service technicians should perform.

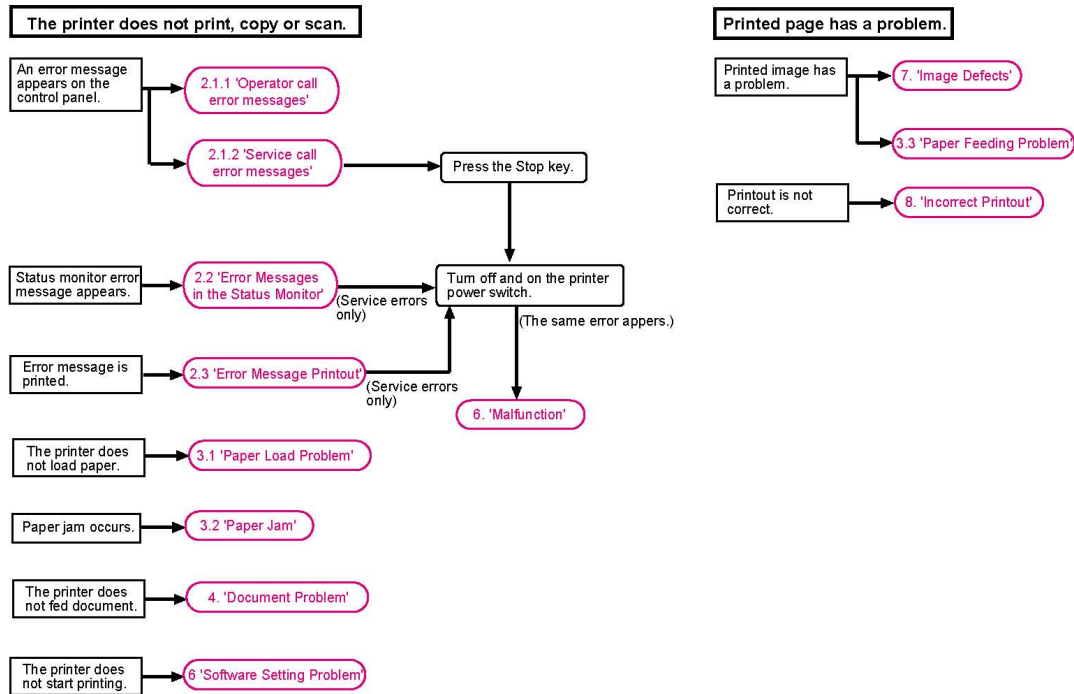

2. ERROR MESSAGES

2.1 Error Messages on the Control Panel

2.1.1 Operator call error messages

When an error occurs during printing, scanning or copying, an error message is shown on the LCD in the control panel. The error messages listed below are user recoverable and the user should take the appropriate action referring to the table below;

Error Message	Remedy
CHANGE DRUM SOON	The drum unit is nearly at the end of its life. Replace the drum unit with a new one. The message will disappear automatically after one minute has passed.
COVER OPEN	Close the front cover. If the front cover is half-opened, the error is not cleared even after closing it. In that case, open the cover once and close it again correctly.
CHECK PAPER CHECK PAPER#1* CHECK PAPER#2* (* When the optional lower tray is installed.)	(1) Load paper into the paper cassette properly. (2) If paper is empty, load a new stack of paper into the cassette. (3) Check that paper in the cassette is straight. If it is curled, straighten it before printing. Sometimes it is helpful to remove the paper, turn the stack over and put it back into the paper cassette. (4) Reduce the amount of paper in the cassette. Keep paper loads below 27mm in depth. (5) Check that the paper is a specified type of paper.
CHECK CASSETTE CHECK CASSETTE #1* CHECK CASSETTE #2* (* When the optional lower tray is installed.)	Check that the paper cassette is installed correctly into the printer.
NO DOCUMENT	Set the original document into the document feeder. The error is cleared automatically, and the copy number is indicated.
PRINTER JAM	Clear the jammed paper inside the printer. Press the Job Cancel button if the printer does not automatically resume printing. For details, see Subsection 3.2 'Paper Jam' in this chapter.
DOCUMENT JAM	Clear the jammed document inside the document feeder. Press the Stop button if the printer does not automatically resume scanning/copying. For details, see Section 4 'Document Problem' in this chapter.
TONER LOW	The toner cartridge is nearly empty. Purchase a new toner cartridge in order to be ready for when the 'toner empty' message is indicated.
TONER EMPTY	There is no toner in the cartridge, or no toner cartridge is installed. Replace the toner cartridge with a new one, or install the cartridge correctly.

Error Message	Remedy
MEMORY FULL	(1) Press the Job Cancel button to print the data remaining in the printer if you are printing. Press the Copy button to print the data remaining in the printer if you are copying. (2) Reduce the print resolution or reduce the complexity of the document. (3) Expand the printer memory by adding an optional memory board.
DOWNLOAD FULL	Press the Job Cancel button to cancel the data remaining in the printer.
COOLING DOWN	Wait for the temperature inside the printer to reduce because the printer is too hot to print.
MANUAL FEED	(1) Set the paper into the manual feed slot. (2) Press the Job Cancel button to print from the paper cassette.
PLS OPEN COVER	Open and close the front cover. The message may disappear if opening/closing the front cover corrects the error.
PLS CLEAN DRUM	(1) Clean the corona wire in the drum unit. (2) If the message is not cleared, open and close the front cover, or press the Stop button.
PRESS STOP KEY	The printer has detected an error due to a software bug. Press the Stop button.
CLEAN UP SCANNER	In the scanning compensation data list printed by the maintenance mode function code 05, less than fifty percent of the white level data is faulty. (This message will appear only in maintenance mode.)
SCANNER ERROR	In the scanning compensation data list printed by the maintenance mode function code 05, fifty percent or more of the white level data is faulty. (This message will appear only in maintenance mode.)

2.1.2 Service call error messages

When the error message below is indicated on the LCD, an unrecoverable service error which the user cannot clear has occurred.

MACHINE ERROR **XX**

'XX' indicates the error code. Identify the error type referring to the error code list below.

Error Code	Cause	LCD Message for End User
71	The polygon motor does not lock.	PLS OPEN COVER **
72	Cannot detect Beam Detect signal.	PLS OPEN COVER
73	No toner cartridge installed.	TONER EMPTY
74	Toner empty.	TONER EMPTY
75	Temperature error.	COOLING DOWN
76	Heater harness disconnected or broken.	MACHINE ERROR 76
77	Heater thermistor short circuit.	MACHINE ERROR 77
78	Heater thermistor harness disconnected or broken.	MACHINE ERROR 78
7A	Main motor locked.	PLS OPEN COVER **
7B	ASIC error on the main PCB.	PLS OPEN COVER **
7C	Engine PCB error.	MACHINE ERROR 7C
80	Paper size setting error.	CHECK PAPER SIZE
82	Paper feeding error.	PRINTER JAM
83	Paper jam. The registration or manual insertion sensor stays ON.	PRINTER JAM
84	Paper jam. The paper eject sensor stays ON.	PRINTER JAM
85	No paper cassette installed.	CHECK CASSETTE CHECK CASSETTE #1
86	No optional lower cassette installed.	CHECK CASSETTE #2
88	Paper jam. Even after the registration sensor has gone OFF, the paper eject sensor still stays OFF.	PRINTER JAM
A1	Front cover opened.	COVER OPEN
A2	Document too long to scan.	DOCUMENT JAM
A3	Document not detected by the document rear sensor.	DOCUMENT JAM
A4	50% or more of white level data is faulty.	SCANNER ERROR (in maintenance mode only)
A7	One-line feeding timeout error.	PRESS STOP KEY
A8	One-line scanning timeout error.	PRESS STOP KEY

Error Code	Cause	LCD Message for End User
A9	Abnormal scanning reference voltage.	N/A
AC	Less than 50% of white level data is faulty.	CLEAN UP SCANNER (in maintenance mode only)
B9	Light emission intensity error of the LED array.	PRESS STOP KEY
E4	Out of recording paper.	CHECK PAPER
E6	Write error in EEPROM.	MACHINE ERROR E6
E8	Data scanning error during transmission.	PRESS STOP KEY
EA	Document removed in phase B.	DOCUMENT JAM
F5	EOL not found in page memory transmission mode.	PRESS STOP KEY
F6	PC interface error.	PC BUSY OR FAIL
FF	Page memory interface error.	FATAL ERROR

**** NOTE:**

For the three errors (71, 7A, 7B), first open/close the front cover when the 'PLS OPEN COVER' message is displayed on LCD. If the same error is still detected after that, a machine error is indicated.

<Remedy>

If any of these service call messages is indicated, press the **Stop** button and turn off the power switch. Wait for a few seconds and then turn it on again and try to print again.

If a service error often occurs, you need to repair or replace the main PCB and the scanner related parts such as CIS.

2.2 Error Messages in the Status Monitor

The status monitor will report problems with the printer as defined in the following table. Take the corrective actions for the error message the status monitor reports.

Error Message	Remedy
COVER OPEN	Close the front cover. If the front cover is half-opened, the error is not cleared even after closing it. In that case, open the cover once and close it again correctly.
CHECK PAPER	<ol style="list-style-type: none"> (1) Load paper into the paper cassette properly. (2) If paper is empty, load a new stack of paper into the cassette. (3) Check that paper in the cassette is straight. If it is curled, straighten it before printing. Sometimes it is helpful to remove the paper, turn the stack over and put it back into the paper cassette. (4) Reduce the amount of paper in the cassette. Keep paper loads below 27mm in depth. (5) Check that paper is a specified type of paper.
PAPER JAM	Clear the jammed paper inside the printer. Press the Job Cancel button if the printer does not automatically resume printing.
TONER LOW	Indicates that the toner cartridge is nearly empty. Purchase a new toner cartridge in order to be ready for when the 'toner empty' message is indicated.
TONER EMPTY	Replace the toner cartridge with a new one.
MEMORY FULL	<ol style="list-style-type: none"> (1) Press the Job Cancel button to print the data remaining in the printer. (2) Reduce the complexity of the document. (3) Expand the printer memory by adding an optional memory board.
FUSER MALFUNCTION	Turn the power switch off, wait a few seconds and then turn it on again. Leave the printer for 10 minutes with power on. If the same error occurs again, see ' M-9 Fuser failure '.
LASER BD MALFUNCTION	Turn the power switch off, wait a few seconds and then turn it on again. If the same error occurs again, see ' M-7 BD failure '.
SCANNER MALFUNCTION	Turn the power switch off, wait a few seconds and then turn it on again. If the same error occurs again, see ' M-8 Scanner failure '.
MAIN MOTOR ERROR	Turn the power switch off, wait a few seconds and then turn it on again. If the same error occurs again, see ' M-3 Main motor fails to rotate '.
ENGINE INTERFACE ERROR	Turn the power switch off, wait a few seconds and then turn it on again. If the same error occurs again, see ' M-10 Engine interface error '.

2.3 Error Message Printouts

The printer will report problems by printing an error message as defined in the following table. Take the corrective actions for the error message the Printout reports.

Error Message	Remedy
RESOLUTION ADAPTED (The printer has printed the document at a reduced resolution.)	Reduce the complexity of the document before printing to prevent automatic reduction of the resolution.
CLEAN DRUM UNIT CORONA WIRE	Clean the corona wire with the wire cleaner.

3. PAPER PROBLEMS

When any paper related problem occurs, ensure that the paper used meets the recommended paper specifications referring to [Subsection 3.6 'Paper' in CHAPTER 1](#).

3.1 Paper Load Problems

Problem	Remedy
The printer does not load paper.	(1) Check that paper in the paper cassette is straight. If it is curled, straighten it before printing. Sometimes it is helpful to remove the paper, turn the stack over and put it back into the paper cassette. (2) Reduce the amount of paper in the cassette. Keep paper loads below 27mm in depth. (3) Check that manual feed mode is not selected in the printer driver.
The printer does not load paper from the manual feed slot.	(1) Re-install the paper firmly into the manual feed slot, one sheet at a time. (2) Check that manual feed mode is selected in the printer driver.
The printer does not load envelopes.	Check that envelopes are loaded into the manual feed slot. The application software must be set up correctly to print on the envelope size you are using.
The printer copies, but nothing is printed on the copy.	Check that the original documents are inserted face down in the document feeder.
The printer does not print into the output tray.	Close the rear cover.
The printer does not print on the specified paper. (optional lower tray unit only)	(1) Check that the Lower tray cable is connected to the printer. (2) Check that the appropriate printer driver is selected.

3.2 Paper Jams

3.2.1 Clear the jammed paper

Clear the jammed paper following the procedures below;

- (1) Remove the paper cassette completely from the printer.
- (2) Pull any jammed paper up and out of the printer. (Fig. 7-1)

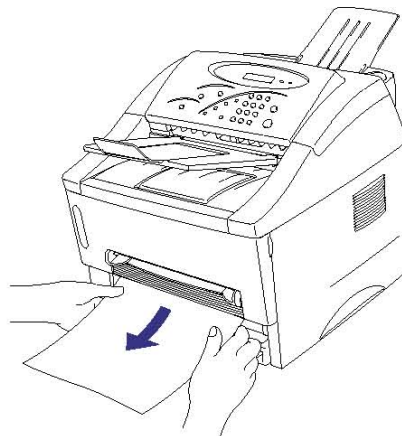

Fig. 7-1

- (3) Open the front cover.
- (4) Remove the drum unit. Pull any jammed paper up and out of the printer. (Fig. 7-2)
- (5) Do not remove the drum unit with additional force at this time if you cannot remove it easily. Instead, pull the edge of the jammed paper from the paper cassette.

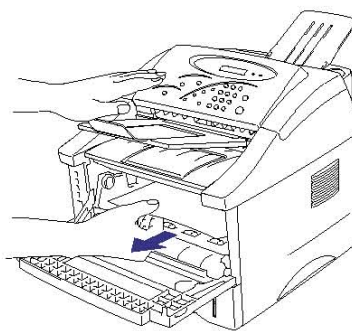

Fig. 7-2

- (6) Open the rear cover and pull the jammed paper out of the fixing unit. If you have to pull the paper towards the back of the printer, the fuser may get dirty with toner powder and may result in toner scatter on the next printed page or pages. Print a few copies of the test page until the toner scatter on the printed pages stops. (Fig. 7-3)

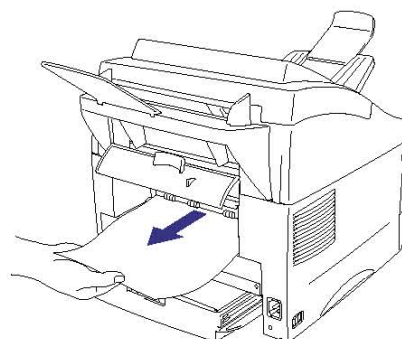

Fig. 7-3

- (7) Close the rear cover.
- (8) Install the drum unit and paper cassette and close the front cover.

NOTE:

If the jammed paper is removed completely, install the paper cassette first, then close the front cover and the printer will resume printing automatically.

3.2.2 Cause & countermeasure

The causes for paper jam problems vary depending on the location of the paper jam. When a paper jam occurs inside the printer, you have to find the location of the paper jam first, remove the jammed paper, and then take an appropriate countermeasure referring to the table below;

Problem	Type of Jam	Cause	Remedy
Jam when the printer is turned on.	Paper stuck	The front registration sensor or paper eject sensor is turned on.	Remove the paper inside the printer. If there is no paper, check the suspect sensors referring to the NOTE below .
Top of paper stopped at 230mm from the second exit roller. Next paper is not fed.	Jam caused by paper length detected as longer than 400mm (16 in).	The front registration sensor is not returning properly and is not turning off.	Check front registration sensor motion referring to the NOTE below .
Bottom of paper stopped around the transfer roller.	Jam caused by paper length detected as shorter than 80mm.	The front registration sensor was turned off early. Malfunction of actuator or hardware noise.	Check the front registration sensor referring to the NOTE below .
Top of paper stopped between the paper feed roller and the pick-up roller.	Jam caused by a paper feed delay.	Paper was not fed in at the proper timing due to paper dust or wear of the rubber of the pick-up roller.	Remove the paper dust attached to the pick-up roller. If the rubber is worn out, replace it with a new one.
Top of paper stopped at 35mm from the contact point of the heat roller and pressure roller.	Jam caused by the paper sensed as not being ejected from the paper eject sensor.	The paper eject sensor does not work properly and is not turning off. (single printing)	Check sensor motion referring to the NOTE below .
Jam after paper is ejected.	Jam caused by the paper sensed as not being ejected from the paper eject sensor.	The paper eject sensor or front registration sensor does not work properly and is not turning off. (continuous printing)	Check sensor motion referring to the NOTE below .

NOTE:

How to check the sensors:

- 1) Enter the maintenance mode. (Turn off the printer power switch, then turn on the printer while pressing the **Job Cancel** button and **1** key.)
- 2) Press the **3** and **2** keys in this order.
- 3) If the front registration sensor and paper eject sensor are detected correctly, the LCD will show the following message;
 - US model: "DFDRCV RSTNPOHKR2" ("MNCSC2" if you press the **Start** button)
 - Europe model: "DFDRCV RSTNPO R2" ("MNCSC2" if you press the **Start** button)
 'RS' and 'PO' in the code as above is indicating the registration sensor or paper eject sensor status.

For details on the sensors, see [Subsection 2.7 'Sensor Operational Check' in CHAPTER 6](#).

3.3 Paper Feeding Problems

Even if the paper is printed and ejected without any problems such as paper jams, paper feeding problems below may appear.

Users can clear these problems by following the 'User Check' items for each problem. If the same problem occurs, however, follow the procedures in the table below.

F-1	Double feeding
-----	----------------

User Check

Check the paper used meets the recommended paper specifications.

Possible cause	Step	Check	Result	Remedy
Separation pad	1	Is the surface of the separation pad worn out?	Yes	Replace the separation pad.

F-2	Wrinkles or creases
-----	---------------------

User Check

- (1) Check that paper is loaded into the paper cassette correctly.
- (2) Check the paper used meets the recommended paper specifications.
- (3) Try printing using the straight-through output path.
- (4) Turn over the stack of paper in the cassette or try rotating the paper 180° in the cassette.

Possible cause	Step	Check	Result	Remedy
Paper	1	Is the problem solved if new paper is used?	Yes	Instruct the user how to store paper so that it does not absorb moisture.
Fixing unit entrance guide	2	Is the entrance guide dirty?	Yes	Clean the entrance guide.
Fixing unit	3	Is the pressure roller dirty?	Yes	Clean the pressure roller.
			No	Replace the fixing unit.

F-3	Page skew
-----	-----------

 **User Check**

- (1) Check that the paper or other media is loaded into the paper cassette correctly and that the paper guides are not too tight or too loose against the paper stack.
- (2) If using the manual feed slot, check that paper is loaded correctly into the manual feed slot.
- (3) The paper cassette may be too full. Load paper below 27mm in depth.
- (4) Check the paper used meets the recommended paper specifications.

F-4	Curl or Wave
-----	--------------

 **User Check**

- (1) Check the paper used meets the recommended paper specifications. Both high temperature and humidity will cause paper to curl.
- (2) If the printer is used infrequently, the paper may have sat for too long in the paper cassette. Turn over the stack of paper in the paper cassette. Also, try rotating the paper 180° in the paper cassette.
- (3) Try printing using the straight-through output path.

NOTE:

For no paper feed malfunctions, see 'M-4 No paper supplied' in Section 6 'Malfunctions'.

4. DOCUMENT PROBLEMS

CAUTION:

When a document jam occurs, pressing the **Stop** button will eject the jammed document. If the document is not ejected, open the control panel cover, then pull the document toward you to remove it.

D-1 'NO DOCUMENT' is shown in LCD although the document is set.

Possible cause	Step	Check	Result	Remedy
Scanner sensor failure	1	Check the sensor works correctly by using the factory inspection program mode.	No	Replace the scanner sensor PCB.
Document front/rear sensor actuators failure	2	Do the document front/rear sensor actuators work correctly?	No	Replace the document front/rear sensor actuators.
Main PCB failure	3	Is the problem solved after the main PCB is replaced?	Yes	Replace the main PCB.

D-2 Documents are not fed.

Possible cause	Step	Check	Result	Remedy
ADF failure	1	Do the ADF and its related parts (especially the separation rubber) work correctly?	No	Replace the defective ADF related parts.
Scanner motor failure	2	Does the scanner motor work correctly? Is the scanner motor harness connected securely?	No	Replace the scanner motor or reconnect the scanner motor harness securely.
Document feed roller failure	3	Do the document feed rollers and their related gears work correctly?	No	Replace the defective document feed roller or gear.
Main PCB failure	4	Is the problem solved after the main PCB is replaced?	Yes	Replace the main PCB.
Document thickness	5	Does the document meet the document specification (thickness, etc.)? Are more documents than the maximum number set in the ADF?	Yes	Set the specified type and number of documents.

D-3	Documents are double-fed.
-----	---------------------------

Possible cause	Step	Check	Result	Remedy
ADF parts failure	1	Do the ADF feed parts (especially the separation rubber) work correctly?	No	Replace the defective ADF parts.
Control panel cover	2	Is a document set with the panel cover opened?	Yes	Re-set the document with the panel cover closed.

D-4	Recording paper is not fed.
-----	-----------------------------

Possible cause	Step	Check	Result	Remedy
Drum unit failure	1	Is the problem solved after the drum unit is replaced?	Yes	Replace the drum unit.
Fixing unit failure	2	Is the problem solved after the fixing unit is replaced?	Yes	Replace the fixing unit.
Drive unit failure	3	Is the problem solved after the drive unit is replaced?	Yes	Replace the drive unit.
Main PCB failure	4	Is the problem solved after the main PCB is replaced?	Yes	Replace the main PCB.

5. SOFTWARE SETTING PROBLEMS

The printer may not print the data correctly with incorrect software settings.

S-1	“There was an error writing to BRPRT: (or LPT1:, BRUSB:, BRLPT1:) for the printer” Error message appears.
-----	---

User Check

- (1) Check that the printer cable is not damaged or broken. Check also that the cable is connected to the correct interface connectors of both the printer and PC.
- (2) Check that the correct printer is selected if you have an interface switching device.
- (3) Check that the appropriate printer driver is selected as 'Set as Default'. Check also that the correct print port is set for the selected printer driver.
- (4) Check that the printer is not connected to the same port which is also connected to a mass storage device or scanner. Remove all other devices and connect the port to the printer only. Turn off printer status monitor in the device options tab in the printer driver.
- (5) If the print port is set as an ECP port, change it to the normal port setting.
- (6) Try printing the test page referring to [Section 1 'Test Print Mode' in CHAPTER 6](#).
- (7) Try resetting the factory setting.

Possible cause	Step	Check	Result	Remedy
Failure inside the printer	1	Is it possible to print the test page with the method in Section 1 'Test Print Mode' in CHAPTER 6 ?	No	Identify the error type, then refer to the specified section in this chapter.
Main PCB failure	2	Is it possible to print with another PC and printer cable?	No	Replace the main PCB.
			Yes	This problem may appear under a specific system environment. Check the environment which the user used.

S-2	Unable to print from application software under DOS.
-----	--

 **User Check**

- (1) Check that the DOS application software interface settings match that of your printer.
- (2) Check if the printer has any printer alarms active.
- (3) Check if the appropriate printer is selected in your application software.

Possible cause	Step	Check	Result	Remedy
Failure inside the printer	1	Is it possible to print the test page with the method in Section 1 'Test Print Mode' in CHAPTER 6?	No	Identify the error type, then refer to the specified section in this chapter.
Main PCB failure	2	Is it possible to print with another PC and printer cable?	No	Replace the main PCB.
			Yes	This problem may appear under a specific system environment. Check the environment which the user used.

S-3	Although the USB driver is installed, it is unable to find the BRUSB: port.
-----	---

 **User Check**

- (1) Re-install the USB driver by following the steps below;
 - i) Double-click the file "DeinsUSB.exe" in the 'Win98USB' directory of the CD-ROM.
 - ii) Turn the printer off and on again.
 - iii) "Add New Hardware Wizard" is launched again, follow the instructions in the Wizard to re-install the driver.
- (2) Try to connect the printer directly to the computer if it is connected through a network.

Possible cause	Step	Check	Result	Remedy
Computer settings	1	Does 'Universal Serial Bus Controllers' appear in the Device Manager tab of 'System Properties' in Control Panel?	No	This problem can be caused by your computer settings. See the computer manual.
USB cable / printer damage	2	Does the 'BRUSB' port appear in the Device Manager tab of 'System Properties' in Control Panel?	No	The USB cable is damaged. Replace the cable. If the same problem appears again, the printer port may be damaged.

S-4	HL-P2500 (or MFC-P2500) does not appear in Chooser with iMac and Power Machintosh G3 with USB.
-----	--

**User Check**

- (1) Check the printer is turned on.
- (2) Check the USB interface cable is connected correctly.
- (3) Check the printer driver is installed correctly.

Possible cause	Step	Check	Result	Remedy
Printer connection	1	Select 'Apple System Profiler' in Apple Menu. Are the following items indicated in the USB box of the Device and Volumes tab? <ul style="list-style-type: none"> • Product ID: 10 (\$A*) • Vender: Brother International Corporation (or 0x4f9) 	No	Check the printer is turned on and the USB interface cable is connected correctly. Check that the USB cable used is the shielded twisted pair type and 5 m or less. Try to connect the printer and PC with the USB cable directly.
Driver installation	2	Are there the following files in the Extensions Folder of System Folder? <For System 8.6 or higher> <ul style="list-style-type: none"> • BR_Backgrounder • BR_PrintMonitor(USB) • HL-1200/MFL Pro • USBPrintDriver <For System 8.1, 8.5, 8.51> <ul style="list-style-type: none"> • BR_Backgrounder • BR_PrintMonitor(USB) • HL-1200/MFL Pro • USBPrintDriver(BR6*) • USBPrintDriver(BR7*) • USBPrintDriver(BR8*) • USBPrintDriver(BR9*) • USBPrintDriver(BRA*) • USBPrintDriver(BR100*) 	No	Try to re-install the printer driver.
			Yes	Turn off the printer and PC power switch, and check all connections between them. Then, turn them on again.

**NOTE:*

The number or letter following 'BR' is a product ID.

6. MALFUNCTIONS

When taking countermeasures for malfunctions as described in this section, check connectors for contact failure before measuring the voltage at the specified connector pins.



WARNING

If you analyze malfunctions with the power plug inserted into the power outlet, special caution should be exercised even if the power switch is OFF because it is a single pole switch.

M-1	No AC power supplied
-----	----------------------

Possible cause	Step	Check	Result	Remedy
Supply voltage	1	Is the correct voltage present at the outlet?	No	Inform the user that the correct voltage is not supplied at the outlet.
Power plug	2	Is the power cord securely plugged into the outlet?	No	Plug the power cord securely into the outlet.
Fuse (F1, F2)	3	Is the fuse blown?	Yes	If the fuse blows again immediately after replacing the low-voltage power supply PCB, check that there is not a short circuit somewhere in the AC power supply line.
Wiring	4	Unplug the power supply plug. Is there a broken wire between the AC input connector of the low-voltage power supply and the power plug?	Yes	Replace the AC power cord.

M-2	No DC power supplied
-----	----------------------

Possible cause	Step	Check	Result	Remedy												
AC power supply	1	Is AC power supplied between connectors CN1-L and CN1-N when the power plug is plugged into the outlet?	No	Follow the same check procedure of M-1 "No AC power supplied".												
Wiring, DC load	2	Turn off the power switch and disconnect the P3 and P5 connectors on the engine PCB. Turn on the power again. Measure the voltages between the terminals. Do the measured voltage satisfy the prescribed valued in the table below?	Yes	Turn off the power switch, reconnect the connector and turn the power switch on again. If the protector circuit is activated, check the connector, the wiring from the connector, and the DC load.												
Low-voltage power supply PCB	3	<table border="1"> <thead> <tr> <th>PCB</th> <th>+ lead pin</th> <th>- lead pin</th> <th>Voltage</th> </tr> </thead> <tbody> <tr> <td>Engine</td> <td>P5-2</td> <td>P5-3</td> <td>Approx. 24V</td> </tr> <tr> <td></td> <td>P3-10</td> <td>P3-9</td> <td>Approx. 5V</td> </tr> </tbody> </table>	PCB	+ lead pin	- lead pin	Voltage	Engine	P5-2	P5-3	Approx. 24V		P3-10	P3-9	Approx. 5V	No	Replace the low-voltage power supply PCB.
PCB	+ lead pin	- lead pin	Voltage													
Engine	P5-2	P5-3	Approx. 24V													
	P3-10	P3-9	Approx. 5V													

**WARNING**

If you analyze malfunctions with the power plug inserted into the power outlet, special caution should be exercised even if the power switch is OFF because it is a single pole switch.

M-3	Main motor fails to rotate
-----	----------------------------

Possible cause	Step	Check	Result	Remedy
Failure of connector	1	Is the connection of connector P9 on the engine PCB correct?	No	Reconnect the connector.
Main motor	2	Is the problem solved by replacing the main motor?	Yes	Replace the main motor.**
Engine PCB	3	Is the problem solved by replacing the engine PCB?	Yes	Replace the engine PCB.
Main PCB	4	Is the problem solved by replacing the main PCB?	Yes	Replace the main PCB.

****NOTE:**

When replacing the main motor, be sure to implement the following actions;

- 1) Turn off the power switch of the printer..
- 2) Turn on the power switch while pressing the **Job Cancel** button and **1** key. The printer enters the maintenance mode.
- 3) Press the **0** and **1** key in this order to enter 'EEPROM Parameter Initialization' mode.
- 4) Set NVRAM to the default setting.

M-4	No paper supplied
------------	--------------------------

Possible cause	Step	Check	Result	Remedy
Failure of connector	1	Is the contact of connector solenoid on the engine PCB good?	No	Reconnect the connector.
Engine PCB circuit	2	Set paper in the manual paper slot and make a test print.	Yes	Replace the engine PCB.
Paper pick-up clutch solenoid		Does the voltage between pins 2 (SOLENOID) and 1 (24V) of the P13 connector on the engine PCB change from approx. 24V DC to 0V within the specified time?	No	Replace the paper pick-up solenoid.
Separation pad / pick-up roller failure	3	Is the surface of the separation pad or the pick-up roller dirty or worn out?	Yes	1) Clean the surface of the separation pad or pick-up roller. 2) Replace the separation pad or pick-up roller.
Main PCB	4	Is the problem solved by replacing the main PCB?	Yes	Replace the main PCB.

M-5	Insufficient output from high-voltage power supply unit
------------	--

Possible cause	Step	Check	Result	Remedy
High-voltage contact	1	Do any of the terminals on the high-voltage contacts have dirt or contact burns?	Yes	Clean the terminals.
High-voltage power supply PCB	2	Check the connections of the connector between the high-voltage power supply and the engine PCB are secured correctly.	Yes	Replace the high-voltage power supply PCB
			No	Reconnect the connector between the high-voltage power supply and the engine PCB.

M-6	Fixing heater temperature failure
------------	--

Possible cause	Step	Check	Result	Remedy
Poor thermistor harness contact	1	Is the contact of connector P6 on the engine PCB good?	No	Reconnect the connector.
Blown thermal fuse	2	Remove the fixing unit and measure the resistance between the input connectors. Is it open circuit?	Yes	Replace the fixing unit after checking Step 4.
Thermistor failure	3	Is the thermistor installed properly?	Yes	Replace the fixing unit.
			No	Reinstall the thermistor properly.
Halogen heater lamp failure	4	Remove the fixing unit and measure the resistance of the halogen heater lamp. Is it open circuit?	Yes	Replace the halogen heater lamp.

M-7	BD failure
------------	-------------------

Possible cause	Step	Check	Result	Remedy
Harness connection failure	1	Is connector P10 on the main PCB secured correctly?	No	Reconnect the connector securely.

M-8	Scanner failure
------------	------------------------

Possible cause	Step	Check	Result	Remedy
Harness connection failure	1	Is the connection of the scanner motor connector P12 on the engine PCB secure?	No	Reconnect the connector securely.
Power supply input	2	Is the voltage between pins 1 (+24V DC) and 2 (GND) of connector P12 on the engine PCB 24V DC?	No	Check if +24V DC is supplied between pins 2 (+24V DC) and 3 (+24V RET) of connector P5 on the engine PCB. If not, check the power supply output on the low-voltage power supply PCB.
			Yes	Replace the laser unit.

M-9	Fuser failure
-----	---------------

Possible cause	Step	Check	Result	Remedy
Poor thermistor harness contact	1	Is the contact of connector P6 on the engine PCB good?	No	Reconnect the connector.
Blown thermal fuse	2	Remove the fixing unit and measure the resistance between the input connectors. Is it open circuit?	Yes	Replace the fixing unit after checking Step 4 below.
Thermistor failure	3	Is the thermistor installed properly?	Yes	Replace the fixing unit.
			No	Reinstall the thermistor properly.
Halogen heater lamp failure	4	Remove the fixing unit and measure the resistance of the halogen heater lamp. Is it open circuit?	Yes	Replace the halogen heater lamp.
Heater harness connection failure	5	Is the heater harness connector connected with the low-voltage power supply PCB and fixing unit securely?	No	Reconnect the connectors securely.

NOTE:

- This problem may be cleared if the printer power is left ON for ten minutes.
- If the heater is cooled down sufficiently, this problem may be cleared by entering the maintenance mode once, then exiting from it. **Be warned, however, that this operation will melt the fixing unit if the heater is hot.**

M-10	Engine interface error
------	------------------------

Possible cause	Step	Check	Result	Remedy
Fixing unit ground wire connection	1	Is the ground wire on the fixing unit secured with the shoulder screw correctly?	No	Secure the ground wire correctly with the shoulder screw.
Harness connection failure	2	Is the connection between connector P6 on the main PCB and connector P3 on the engine PCB secure?	No	Reconnect the connectors securely.
Engine PCB	3	Is the problem solved by replacing the engine PCB?	Yes	Replace the engine PCB.
Main PCB	4	Is the problem solved by replacing the main PCB?	Yes	Replace the main PCB.

7. IMAGE DEFECTS

7.1 Image Defect Examples

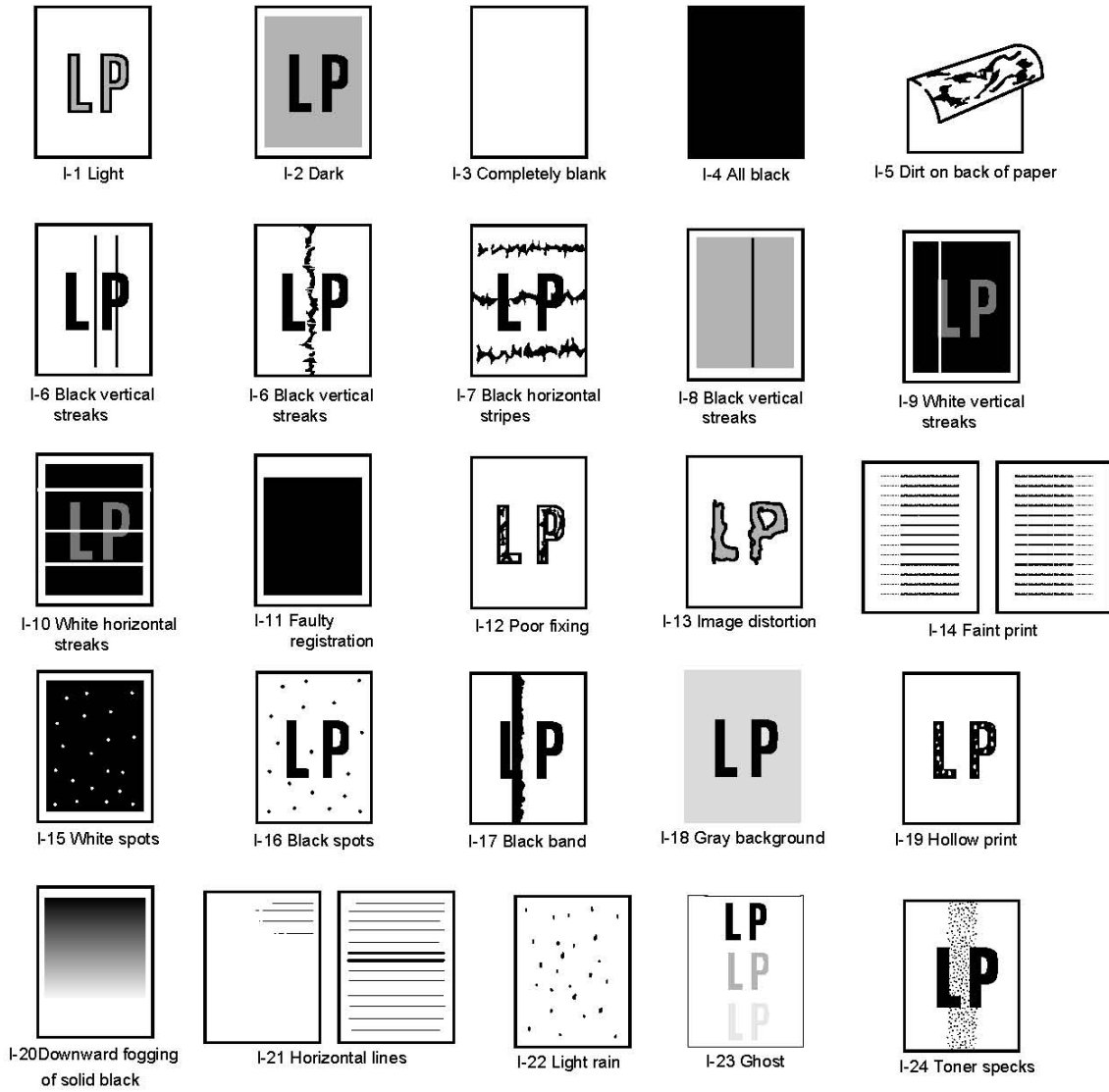

Fig. 7-4

7.2 Troubleshooting Image Defect

The following procedures should be followed in the event of specific image defects.

Before you can establish the cause of an image defect you need to identify whether the image defect comes from the scanning side or the printing side to take the appropriate action.

Implement both direct copying and printing from the printer itself (ex. test print), and find which causes the defect referring to the table below;

Cause	Copying result	Printing result
Scanning side	X	○
Printing side	X	X

X = No good ○ = OK

See also [Subsection 7.3](#) for information about the location of the grounding contacts.

⚠ CAUTION:

When using the printer for a special job, such as printing of name cards, print quality can not be guaranteed.

I-1	Light
-----	-------

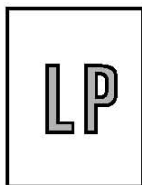

 **User Check**

- (1) Check the printer's environment. Conditions such as humidity, high temperatures, etc. may cause this situation to occur.
- (2) If the whole page is light, toner save mode may be on. Disable toner save mode within Printer Properties tab in the driver.
- (3) Try installing a new toner cartridge or drum unit.

<Scanning>

Possible cause	Step	Check	Result	Remedy
Main PCB failure	1	Is the problem solved after the main PCB is replaced?	Yes	Replace the main PCB.
Laser unit failure	2	Is the problem solved after the laser unit is replaced?	Yes	Replace the laser unit.

<Printing>

Possible cause	Step	Check	Result	Remedy	Ground contacts
Toner sensing failure (printer side)	1	Can printing be started with the drum unit and toner cartridge removed?	Yes	Check if the toner sensor is dirty and check the toner sensor connection.	
Toner sensing failure (toner cartridge side)	2	Is the problem solved when 4 or 5 pages are printed after the toner cartridge is replaced with a full one?	Yes	The wiper of the toner cartridge is defective. Replace the toner cartridge.	
Drum connection failure	3	Are all the contacts between the drum unit and printer body connected correctly?	No	Clean contact electrodes both on the drum unit and in the printer body.	①, ④, ⑤, ⑥
High-voltage power supply PCB failure	4	Is the harness connection between the high-voltage power supply PCB and the engine PCB correct?	Yes	Replace the high-voltage power supply PCB.	
Engine PCB / Main PCB failure	5	Is the harness connection between the engine PCB and the main PCB correct?	Yes	Replace the engine PCB or the main PCB.	
Dirt on the scanner window	6	Is there any dirt on the scanner window?	Yes	Wipe it off with a soft clean paper.	
Laser unit failure	7	Is the problem solved after replacing the laser unit?	Yes	Replace the laser unit.	

I-2	Dark
-----	------



User Check

- (1) Check the paper used meets the recommended paper specifications.
- (2) Check the printer's environment. High temperature and high humidity conditions can increase the amount of background shading.
- (3) Clean the corona wire with the wire cleaner.
- (4) Try installing a new toner cartridge or drum unit.

<Scanning>

Possible cause	Step	Check	Result	Remedy
Main PCB failure	1	Is the problem solved after the main PCB is replaced?	Yes	Replace the main PCB.
Laser unit failure	2	Is the problem solved after the laser unit is replaced?	Yes	Replace the laser unit.

<Printing>

Possible cause	Step	Check	Result	Remedy	Ground contacts
Corona failure (contact failure)	1	Are the charge electrodes between the printer body and drum unit dirty?	Yes	Clean both electrodes.	③
Drum unit failure	2	Is the problem solved after replacing the drum unit?	Yes	Replace the drum unit with a new one.	
Toner cartridge failure	3	Is the problem solved after replacing the toner cartridge?	Yes	Replace the toner cartridge with a new one.	
High-voltage power supply PCB failure	4	Is the connector between the high-voltage power supply PCB and the engine PCB secured correctly?	Yes	Replace the high-voltage power supply PCB.	
Main PCB failure	5	Are there any disconnected connectors?	No	Replace the main PCB.	
Engine PCB failure	6	Are there any disconnected connectors?	No	Replace the engine PCB.	

I-3	Completely blank
-----	------------------

**<Scanning>**

Possible cause	Step	Check	Result	Remedy
CIS harness connection	1	Is the CIS harness connected securely?	No	Reconnect the CIS harness.
CIS unit failure	2	Is the problem solved after the CIS unit is replaced?	Yes	Replace the CIS unit.
Sensor harness connection	3	Is the sensor harness connected between the main PCB and the scanner sensor PCB securely?	No	Reconnect the sensor harness.
Main PCB failure	4	Is the problem solved after the main PCB is replaced?	Yes	Replace the main PCB.

<Printing>

Possible cause	Step	Check	Result	Remedy	Ground contacts
Developing bias contact failure	1	Are the developing bias contacts between the printer body and toner cartridge dirty?	Yes	Clean the electrodes at both sides.	④
Drum unit	2	Are the drum shaft and drum electrode of the printer body connected correctly?	Yes	Clean the shaft and the electrode.	①
			No	Check the connection between the shaft and the electrode.	①
Drum unit failure	3	Is the problem solved after replacing the drum unit?	Yes	Replace the drum unit.	
Toner cartridge failure	4	Is the problem solved after replacing the toner cartridge?	Yes	Replace the toner cartridge.	
Scanner harness connection failure	5	Is the scanner harness connected securely? (Check if there is any play in the connection.)	No	Reconnect the connector correctly.	
Main PCB failure	6	Are printing signals being input to the laser unit? Is the problem solved after replacing the main PCB?	Yes	Replace the main PCB.	
Laser unit failure	7	Is the scanner interlock lever damaged?	Yes	Replace the laser unit.	
		Is the scanner mirror broken or loose?	No	Replace the high-voltage power supply PCB.	

I-4	All black
-----	-----------



 **User Check**

- (1) Clean the corona wire of the drum unit.
- (2) The drum unit may be damaged. Install a new drum unit.

<Scanning>

Possible cause	Step	Check	Result	Remedy
CIS harness connection	1	Is the CIS harness connected securely?	No	Reconnect the CIS harness.
CIS unit failure	2	Is the problem solved after the CIS unit is replaced?	Yes	Replace the CIS unit.
Sensor harness connection	3	Is the sensor harness connected between the main PCB and the scanner sensor PCB securely?	No	Reconnect the sensor harness.
Main PCB failure	4	Is the problem solved after the main PCB is replaced?	Yes	Replace the main PCB.

<Printing>

Possible cause	Step	Check	Result	Remedy	Ground contacts
Corona failure	1	Is the corona wire dirty?	Yes	Clean the corona wire with the wire cleaner.	②
	2	Is the corona broken?	Yes	Replace the drum unit.	
	3	Are the charge electrodes between the printer body and the drum unit dirty?	Yes	Clean both electrodes.	③
Harness connection	4	Is the laser unit connected with the main PCB correctly?	No	Connect the harness between the laser unit and the main PCB correctly.	
High-voltage power supply PCB failure	5	Is the problem solved after replacing the high-voltage power supply PCB?	Yes	Replace the high-voltage power supply PCB.	
Main PCB failure	6	Is the problem solved after replacing the main PCB?	Yes	Replace the main PCB.	

NOTE:

- If you print the same pattern continuously, the drum will be worn and black vertical streaks will appear on the paper.
- This problem may occur with *noise* due to the corona wire being dirty. In that case, clean the corona wire with the wire cleaner.

I-5	Dirt on the back of paper
-----	---------------------------

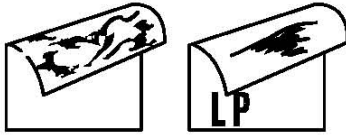

<Printing>

Possible cause	Step	Check	Result	Remedy
Fixing unit dirty	1	Is the pressure roller dirty? Is any other area in the printer dirty?	Yes	Clean the pressure roller referring to the following procedure .
Dirt in the drum unit	2	Is the transfer roller dirty? Is the problem solved after replacing the drum unit?	Yes	Replace the drum unit
			No	Replace the high-voltage power supply PCB.

NOTE:

- This problem may disappear after printing approximately 10 pages of completely blank sheets.
- The dirt on the back of paper as shown at the right is caused by toner on the star wheel hooks in the fixing unit. This problem may disappear after printing a few pages.

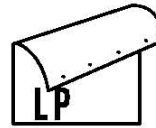

Fig. 7-5

How to clean the pressure roller

Clean the pressure roller as follows;

- (1) Prepare three sheets of blank A4 or Letter-size paper.
- (2) Set the sheets into the automatic document feeder.
- (3) Press the **Copy** button to copy them.

I-6	Black and blurred vertical streaks
-----	------------------------------------

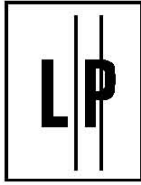

User Check

- (1) Clean the corona wire in the drum unit.
- (2) Check that the corona wire cleaner is at the home position.
- (3) Check that the toner cartridge is not empty.
- (4) The drum unit may be damaged. Install a new drum unit.
- (5) The toner cartridge may be damaged. Install a new toner cartridge.

<Scanning>

Possible cause	Step	Check	Result	Remedy
Dirt on the CIS window	1	Is there any dirt on the CIS window?	Yes	Clean the CIS window.
Dirt on the document pressure bar	2	Is the document pressure bar dirty?	Yes	Clean the document pressure bar.
Scratch on the document pressure bar	3	Are there any scratches on the document pressure bar?	Yes	Replace the document pressure bar.

<Printing>

Possible cause	Step	Check	Result	Remedy
Corona failure	1	Is the vertical block streak about 10mm wide? (Check if the wire cleaner is at its home position.)	Yes	Return the wire cleaner to its home position.
Dirt in the paper feed system	2	Is the paper cassette or feed system on the drum unit dirty with toner?	Yes	Clean the toner off.
Scratch on the drum	3	Is the drum surface scratched?	Yes	Replace the drum unit.
Cleaning failure	4	Is the drum surface dirty with toner in streaks?	Yes	Replace the drum unit.
Scratch on the heat roller	5	Is the surface of the heat roller scratched?	Yes	Replace the fixing unit.

NOTE:

- If you print the same pattern continuously, the drum will be worn and black vertical streaks will appear on the paper.
- This problem may occur with noise due to the corona wire dirty. In that case, clean the corona wire with the wire cleaner.

I-7	Black and blurred horizontal stripes
-----	--------------------------------------

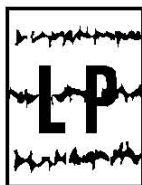

 **User Check**

- (1) The drum unit may be damaged. Install a new drum unit.
- (2) Check the paper used meets the recommended paper specifications.
- (3) Clean the printer interior and the corona wire in the drum unit.

<Printing>

Possible cause	Step	Check	Result	Remedy	Ground contacts
Scratch on the drum	1	Are the horizontal stripes at 94mm (photosensitive drum) intervals?	Yes	The photosensitive drum is scratched. Replace the drum unit.	
Toner stuck on the developer roller	2	Are the horizontal stripes at 39mm (developer roller) intervals?	Yes	After printing several pages, the problem will disappear. If not, replace the toner cartridge.	
Scratch on the heat roller	3	Are the horizontal stripes at 79mm (heat roller) intervals?	Yes	Replace the heat roller.	
Corona contact failure	4	Are the charge electrodes between the printer body and the drum unit dirty?	Yes	Clean both electrodes.	③
High-voltage power supply PCB failure	5	Is the problem solved after replacing the high-voltage power supply PCB?	Yes	Replace the high-voltage power supply PCB.	

I-8	Black vertical streaks (in a gray background)
-----	---

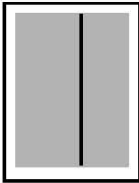

<Scanning>

Possible cause	Step	Check	Result	Remedy
Dirt on the CIS window	1	Is there any dirt on the CIS window?	Yes	Clean the CIS window.
CIS unit failure	2	Is the problem solved after the CIS unit is replaced?	Yes	Replace the CIS unit.

<Printing>

Possible cause	Step	Check	Result	Remedy	Ground contacts
Translucent mark on the scanner window	1	Are there any marks on the scanner window?	Yes	1) Clean the scanner window. 2) If it is not effective, replace the laser unit.	
Corona failure	2	Is the corona wire dirty?	Yes	Clean the corona wire with the wire cleaner.	②

I-9	White vertical streaks
-----	------------------------



 **User Check**

- (1) Try to wipe the scanner window with a soft cloth.
- (2) The toner cartridge may be damaged. Install a new toner cartridge.
- (3) Check the printer's environment. High temperature and high humidity conditions can cause this problem.
- (4) Damp (wet) paper might be being used. Try to change to freshly unpacked

<Scanning>

Possible cause	Step	Check	Result	Remedy
Dirt on the CIS window	1	Is there any dirt on the CIS window?	Yes	Clean the CIS window.
CIS unit failure	2	Is the problem solved after the CIS unit is replaced?	Yes	Replace the CIS unit.
Dirt on the document pressure bar	3	Is there any dirt on the document pressure bar?	Yes	Clean the document pressure bar.
Scratch on the document pressure bar	4	Are there any scratches on the document pressure bar?	Yes	Replace the document pressure bar.

<Printing>

Possible cause	Step	Check	Result	Remedy
Transfer failure	1	Is the transfer roller scratched?	Yes	Replace the drum unit.
Condensation	2	Has condensation occurred inside the printer?	Yes	Try to print several pages or leave the printer 2 hours to allow it to reach room temperature.

I-10	White horizontal stripes
------	--------------------------

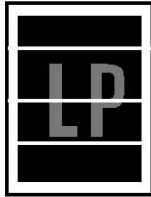

User Check

- (1) Check the paper used meets the recommended paper specifications. A rough surfaced paper, damp paper or thick media can cause the problem.
- (2) Check that the appropriate media type is selected in the printer driver.
- (3) The problem may disappear by itself. Try printing multiple pages to clear this problem especially if the printer has not been used for a long time.
- (4) The drum unit may be damaged. Install a new drum unit.

<Printing>

Possible cause	Step	Check	Result	Remedy	Ground contacts
Developing bias contact failure	1	Are the developing bias contacts between the printer body and toner cartridge dirty?	Yes	Clean the electrodes at both sides.	④

I-11	Faulty registration
------	---------------------



<Printing>

Possible cause	Step	Check	Result	Remedy
Excessive paper load	1	Is the paper loaded in the paper cassette more than 27mm height?	Yes	Instruct the user to keep paper loads below 27mm in depth.
Print paper	2	Is the specified weight of the recommended paper being used?	No	Recommend to use the specified types of paper.
	3	Is the first printing position within ± 1 mm of the tolerance specification?	Yes	Adjust the Y offset by using the utility software supplied.
Rear registration sensor position incorrect	4	Is the position of the rear registration sensor normal?	No	Reposition the sensor to the correct position.

I-12	Poor fixing
------	-------------

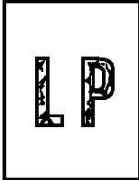
**<Printing>**

Possible cause	Step	Check	Result	Remedy
Print paper	1	Is thick paper of more than 43lb being used?	Yes	Recommend to use the specified types of paper.
Toner sensing failure (When printing is faint.)	2	Is the problem solved by replacing the drum unit or the toner cartridge?	Yes	1) Toner is empty. 2) The toner sensing is defective. Clean the toner sensor. 3) If the wiper in the toner cartridge is broken, replace the toner cartridge with a new one.
Thermistor failure	3	Is the thermistor fitted correctly?	No	Fit the thermistor correctly.
Low-voltage power supply PCB failure	4	Is the problem solved by replacing the low-voltage power supply PCB?	Yes	Replace the low-voltage power supply PCB.

I-13	Image distortion
------	------------------

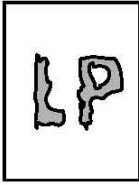
**<Scanning>**

Possible cause	Step	Check	Result	Remedy
Separation roller failure	1	Do the separation roller and its related parts work correctly?	No	Replace the separation roller or its related parts.
Document feed roller failure	2	Do the document feed roller and related gears work correctly?	No	Replace the document feed rollers or related gears.
Scanner motor failure	3	Does the scanner motor work correctly? Is the scanner motor harness connected securely?	No	Replace the scanner motor, or reconnect the scanner motor harness correctly.
Main PCB failure	4	Is the problem solved after the main PCB is replaced?	Yes	Replace the main PCB.

<Printing>

Possible cause	Step	Check	Result	Remedy
Laser unit installation	1	Is the laser unit secured to the frame incorrectly? (Check if there is any play.)	Yes	Secure the unit correctly and tighten the screws.
Scanner LD emission failure Scanner motor rotation failure	2	Is the laser diode or the scanner motor defective?	Yes	Replace the laser unit.
Scanner connection failure	3	Is the scanner harness connected properly? (Check if it is coming loose.)	Yes	Connect the harness correctly.

I-14	Faint print
------	-------------

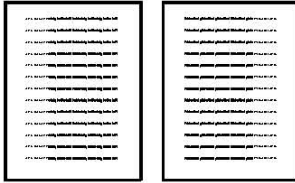
**<Printing>**

Possible cause	Step	Check	Result	Remedy
Printer installation	1	Is the printer placed horizontally?	No	Place the printer on a flat surface.
Toner cartridge	2	Does the problem happened immediately after replacing the toner cartridge with a new one?	Yes	Remove and carefully shake the toner cartridge horizontally.
Scanner window dirty	3	Is the scanner window dirty?	Yes	Clean the scanner window with a soft dry cloth.
Laser unit failure	4	Is the problem solved by replacing the laser unit?	Yes	Replace the laser unit.

I-15

White spots

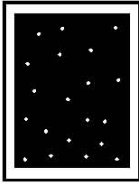
 **User Check**

- (1) If the problem is not solved after printing a few pages, the drum unit may have glue from label stock on the photosensitive drum surface. Refer to Step 1 in the table below and **NOTE** in the following page.
- (2) The drum unit may be damaged. Install a new drum unit.

<Printing>

Possible cause	Step	Check	Result	Remedy
Drum unit failure	1	Are the white spots at 94mm intervals?	Yes	1) If toner or glue remains stuck, wipe it off gently with a cotton swab. (Refer to NOTE on the following page.) 2) If the drum surface is scratched, replace the drum unit.
Drum unit failure	2	Is the problem solved after replacing the drum unit?	Yes	Replace the drum unit.
No toner	3	Is the toner in the toner cartridge almost empty?	Yes	Replace the toner cartridge with a new one.
Print paper	4	Is the problem solved after change to specified freshly unpacked paper?	Yes	Damp (wet) paper might be used. Recommend to change to freshly unpacked paper.
Environment	5	Does the problem still appear after the printer has warmed up?	Yes	1) Replace the drum unit. 2) Advise the user of the specified print environment.

NOTE:

Clean the drum unit as follows:

- (1) Remove the toner cartridge from the drum unit. Place the printing samples in front of the drum unit, and find the exact position of the image defect.

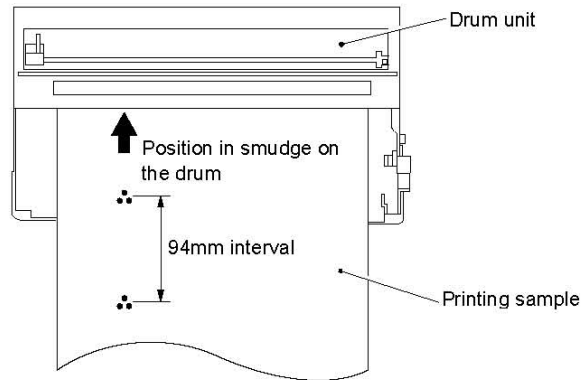

Fig. 7-6

- (2) Turn the drum gear by hand while looking at the surface of the photosensitive drum.

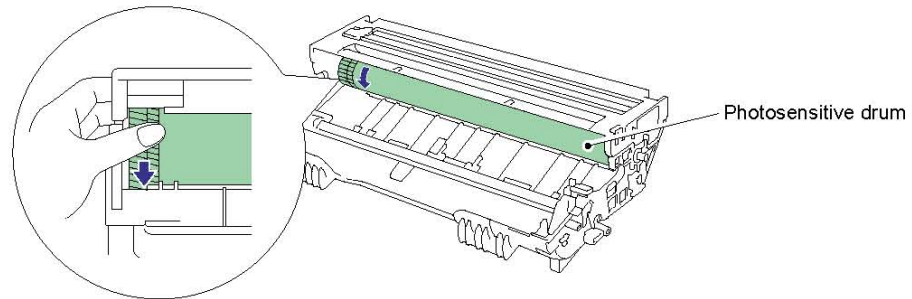

Fig. 7-7

- (3) Wipe the surface of the photosensitive drum with a cotton swab until the dust or paper powder on the surface comes off.

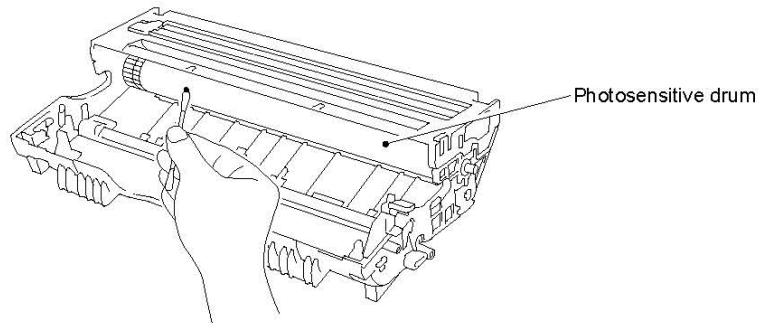

Fig. 7-8

CAUTION:

- Do not wipe the surface of the photosensitive drum with something sharp. (ball-point pen etc.)
- Use cleaning liquid which is a 50-50 mixture of ethyl alcohol and pure water.

I-16	Black spots
------	-------------



 **User Check**

- (1) If the problem is not solved after printing a few pages, the drum unit may have glue from label stock on the photosensitive drum surface. Refer to **Step 1** in the table below and **NOTE** on the previous page.
- (2) The drum unit may be damaged. Install a new drum unit.

<Printing>

Possible cause	Step	Check	Result	Remedy
Drum unit	1	Are the spots at 94mm intervals? (The problem is not solved after printing a few pages.)	Yes	1) If toner or glue remains stuck, wipe it off gently with a cotton swab. (Refer to NOTE on the previous page.) 2) If the photosensitive drum is scratched or deteriorated (exposed), replace the drum unit.
Fixing unit	2	Are the spots at 79mm intervals? (The problem is not solved after printing a few pages.)	Yes	1) Check and clean the heat roller with a cloth dampened with alcohol. 2) Replace the fixing unit.
High-voltage power supply PCB failure	3	Is the problem solved after replacing the high-voltage power supply PCB?	Yes	Replace the high-voltage power supply PCB.

I-17	Black band
------	------------



<Printing>

Possible cause	Step	Check	Result	Remedy	Ground contacts
Corona failure	1	Is the wire cleaner at its home position?	No	Return the wire cleaner to its home position.	②
Corona failure	2	Is the corona wire dirty?	Yes	1) Clean the corona wire. 2) If the problem still appears after cleaning, replace the drum unit.	②

I-18

Gray background

LP

<Printing>

Possible cause	Step	Check	Result	Remedy
Print paper	1	Does the paper being used meet the paper specification (weight, etc.).	No	Recommend to use the specified types of paper.
			Yes	Recommend to change to freshly unpacked paper.
Toner sensing failure (printer side)	2	Is Ready LED on even after removing the drum unit and toner cartridge?	Yes	Toner sensor failure. Clean the toner sensor and check the toner sensor connection.
Toner cartridge failure	3	Is the problem solved after replacing the toner cartridge?	Yes	Replace the toner cartridge.
Drum unit failure	4	Is the problem solved after replacing the drum unit?	Yes	Replace the drum unit.
			No	Replace the high-voltage power supply PCB.

NOTE:

The following cases increase the possibility of this problem.

- Acid paper is being used.
- The drum unit is at the end of its life.
- There is dust or paper powder.

I-19

Hollow print

LP

 **User Check**

- (1) Check the paper used meets the recommended paper specifications.
- (2) Select the 'Thick paper mode' in the printer driver, or use thinner paper than currently in use.
- (3) Check the printer's environment, conditions such as high humidity may cause this situation to occur.

<Printing>

Possible cause	Step	Check	Result	Remedy
Print paper	1	Is thick paper of more than 43lb being used or extremely rough surface paper?	Yes	Recommend to use the specified types of paper.
			No	Refer and compare with I-15 .

I-20	Downward fogging of solid black
------	---------------------------------



<Printing>

Possible cause	Step	Check	Result	Remedy
Toner cartridge failure	1	Is the problem solved after replacing the toner cartridge?	Yes	Replace the toner cartridge.
High-voltage power supply PCB failure	2	Is the problem solved after replacing the high-voltage power supply PCB?	Yes	Replace the high-voltage power supply PCB.

I-21	Horizontal lines
------	------------------



<Printing>

Possible cause	Step	Check	Result	Remedy	Ground contacts
Paper feed roller	1	Are the feed roller shaft and the ground contact connected correctly?	No	Check the connection between the shaft and the ground contact. Also check the ground contacts on the back of the feed roller. Refer to P. 4-38.	
Paper cassette contacts	2	Are the ground contacts on the rear of the paper cassette connected correctly?	No	Check the contacts.	⑦

I-22	Light rain
------	------------

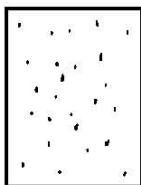

<Printing>

Possible cause	Step	Check	Result	Remedy
Drum unit failure	1	Is the problem solved after replacing the drum unit?	Yes	Replace the drum unit.
High-voltage power supply PCB failure	2	Is the problem solved after replacing the high-voltage power supply PCB?	Yes	Replace the high-voltage power supply PCB.

I-23	Ghost
------	-------

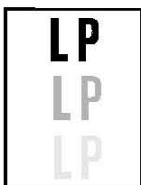

 User Check

- (1) Check the paper used meets the recommended paper specifications. Damp paper, thick media or rough surfaced paper can cause the problem.
- (2) Check the printer's environment. High temperature and high humidity conditions can cause the problem.
- (3) Check that the appropriate media type is selected in the printer driver.
- (4) Try installing a new drum unit.

<Printing>

Possible cause	Step	Check	Result	Remedy
Driver setting	1	Is thin paper such as 64g/m ² being used in thick paper mode?	Yes	1) Change the current mode to the normal mode from the driver setting. 2) Print 5 or 6 blank pages if this problem occurs.
Drum unit failure	2	Is the problem solved after replacing the drum unit?	Yes	Replace the drum unit.
High-voltage power supply PCB failure	3	Is the problem solved after replacing the high-voltage power supply PCB?	Yes	Replace the high-voltage power supply PCB.

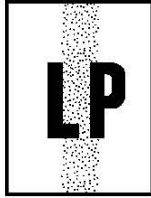
I-24	Toner specks
------	--------------



 **User Check**

- (1) Check the paper used meets the recommended paper specifications. A rough surfaced paper may cause the problem.
- (2) The toner cartridge may be damaged. Install a new toner cartridge.
- (3) The drum unit may be damaged, or may be nearly at the end of life. Install a new drum unit.

7.3 Location of Grounding Contacts

7.3.1 Drum unit

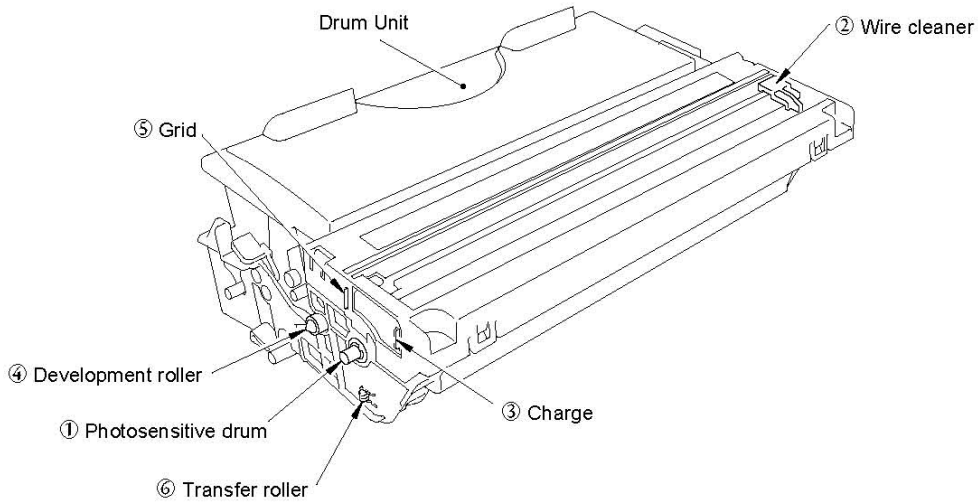

Fig. 7-9

7.3.2 Printer body & Paper cassette

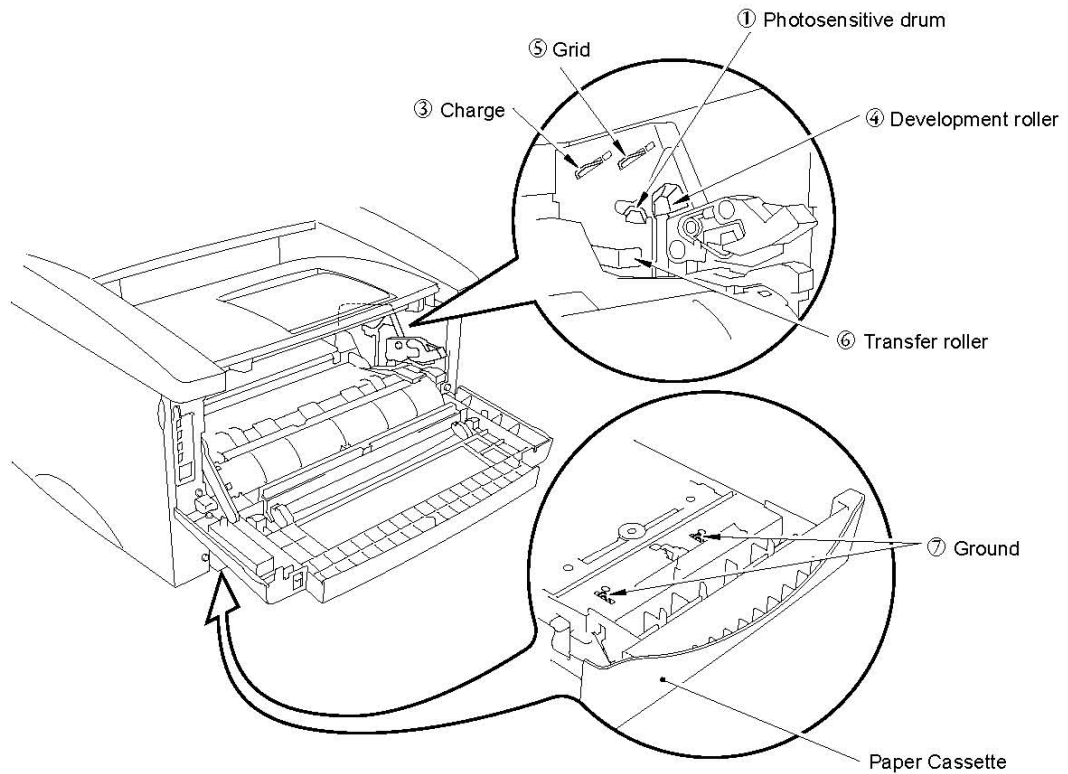

Fig. 7-10

8. INCORRECT PRINTOUT

When the data is not printed correctly as it is seen on the PC screen, follow the procedures below.

P-1	The printer prints unexpectedly or it prints garbage.
-----	---

User Check

- (1) Check the printer cable is not too long. It is recommended to use a parallel cable of less than 2 meters (6.6 feet) in length.
- (2) Check that the printer cable is not damaged or broken. Check also that the printer cable is connected to the correct interface connectors of both the printer and PC.
- (3) If an interface switching device is used, remove it and connect the computer directly to the printer and try again.
- (4) Check that the appropriate printer driver is selected as 'Set as Default'. Check also that the correct print port is set for the selected printer driver.
- (5) Check that the printer is not connected to the same port which is also connected to a mass storage device or scanner. Remove all other devices and connect the port to the printer only. Turn off printer status monitor in the device options tab in the printer driver.
- (6) If the print port is set as an ECP port, change it to the normal port settings.
- (7) Try printing the test page referring to [Section 1 'Test Print Mode' in CHAPTER 6](#).
- (8) Try resetting the factory settings.

Possible cause	Step	Check	Result	Remedy
Failure inside the printer	1	Is it possible to print the test page with the method in Section 1 'Test Print Mode' in CHAPTER 6 ?	No	Identify the error type, then refer to the specified section in this chapter.
Main PCB failure	2	Is it possible to print with another PC and printer cable ?	No	Replace the main PCB.
			Yes	This problem may appear under a specific system environment. Check the environment that the user used.

P-2	Unable to print full pages in a document with a "MEMORY FULL" message.
-----	--

 **User Check**

- (1) Press the **Job Cancel** button to print the data remaining in the printer.
- (2) Reduce the complexity in your document or reduce the printer resolution.
- (3) Expand the printer memory by adding an optional memory board.

NOTE:

This problem may appear if the data is too complex. Try to take the following procedures.

Possible cause	Step	Check	Result	Remedy
Unable to recognize a memory board	1	Check the memory size in Print Configuration. Is it the default size?	Yes	Expand the memory size by adding a memory board. If the memory is maximum size, it will be impossible to print the data under the printer specifications.
Memory board / main PCB failure	2	Try installing the memory board into another printer, then check the memory size in Print Configuration. Is it possible to print the data?	Yes	Replace the memory board.
			No	Replace the main PCB.

P-3	Headers or footers are not printed out even though they are viewed on the PC
-----	--

 **User Check**

Most laser printers have a restricted area that cannot be printed on. Usually the first two lines and last two lines in text cannot print (leaving 62 printable lines). Adjust the top and bottom margins in your document to allow for this.

P-4	The printer sometimes prints a couple in characters and then ejects the page.
-----	---

 **User Check**

(For DOS environment only)

The application printer emulation setting and the printer's emulation do not match. Check in the application software which printer you have selected to make sure the printer is set up correctly. Remember the printer emulates the widely used printer HP LaserJet 5P (PCL5e). Try setting the printer into HP emulation and then select the HP LaserJet 5 printer in the application software.

P-5	The printer copies, but nothing is printed on the copy
-----	--

 **User Check**

Check the following:

- (1) Original documents are inserted face down in the document feeder.
- (2) The toner cartridge is not empty.

Possible cause	Step	Check	Result	Remedy
CIS failure	1	When code 55 is implemented in maintenance mode, is the 'SCANNER ERROR' message displayed on the LCD?	Yes	Replace the CIS unit.
			No	Replace the main PCB.

P-6	Some portion of the image is missing on the copy.
-----	---

 **User Check**

- (1) The printer has unscannable and unprintable areas. Check the areas referring to [Subsection '3.8.3 Scannable area' in Chapter 1](#).
- (2) If the image is larger than the paper size, some of the image may be lost.

Possible cause	Step	Check	Result	Remedy
CIS failure	1	When code 55 is implemented in maintenance mode, is the 'SCANNER ERROR' message displayed on the LCD?	Yes	Replace the CIS unit.
			No	Replace the main PCB.

P-7	Unable to copy full pages of a document with the "MEMORY FULL"
-----	--

 **User Check**

- (1) Select stack mode instead of sort mode.
- (2) Expand the printer memory by adding an optional memory board.

APPENDIX 1. SERIAL NO. DESCRIPTIONS

The descriptions below show how to read the labels on the printer and printer parts.

< ID for production month >

A: January	B: February	C: March	D: April
E: May	F: June	G: July	H: August
J: September	K: October	L: November	M: December

< ID for factory >

9: Kariya Plant	A: Mie Brother	C: BIUK
J: Buji Nan Ling Factory		

(1) Printeron the main body

<MODEL NO.>						< SERIAL NO. >					
XXXXXXXXH						9J111101					
											SEQUENTIAL NO.
											FACTORY ID NO.
											YEAR
											MONTH

(2) Process uniton the package of the process unit
(Drum unit with toner cartridge)

9		F		30		00		00		ANB	
YEAR	MONTH			DATE						LINE NO.	TONER TYPE
											SERIAL NO.

(3) Drum uniton the drum unit

9		FB		00000		01	
YEAR	MONTH						SERIAL NO.
							ASSEMBLY

(4) Toner cartridge on the toner cartridge

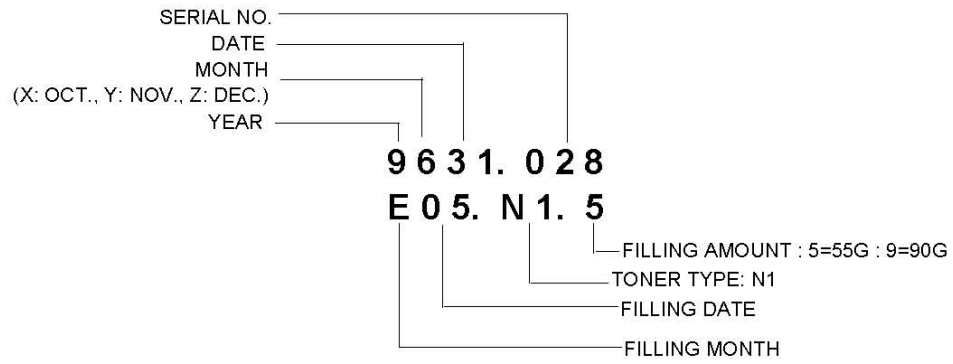

(5) Laser unit on the laser unit

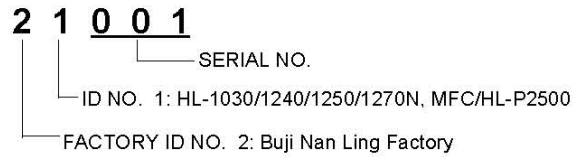

APPENDIX 2. DIAMETER / CIRCUMFERENCE OF ROLLERS

The diameter and circumference of each roller are listed below;

No.	Parts Name	Diameter (Circumference)
1	Paper Feed Roller	ϕ 14.0 mm (44.0 mm)
2	Transfer Roller	ϕ 16.90 mm (53.1 mm)
3	Photosensitive Drum	ϕ 29.97 mm (94.1 mm)
4	Heat Roller	ϕ 25.0 mm (78.5 mm)
5	Pressure Roller	ϕ 20.0 mm (62.8 mm)
6	Development Roller	ϕ 20.0 mm (39.0 mm)

APPENDIX 3. PRINT SPEEDS WITH VARIOUS SETTINGS

Print speed of the printer is up to 12 ppm when loading A4 or Letter size paper from the paper cassette in the Regular mode.

Actual print speed varies depending on the media type or paper size as shown in the tables below;

<A4 or Letter size>

Media type setting	All models
Transparency	up to 12 ppm
Thin Paper	up to 12 ppm
Regular	up to 12 ppm
Thick Paper	up to 12 ppm
Thicker/Bond Paper	A4: 3 ppm / Letter: 3 ppm or more

<Smaller size than A4 or Letter>

Media type setting	All models
Transparency	Max. speed
Thin Paper	Max. speed
Regular	12 ppm after 5 min. have passed.
Thick Paper	6 ppm after 30 sec. have passed.
Thicker/Bond Paper	A6: 3.75 ppm

NOTE:

- *When a smaller size paper than A4 or Letter is printed, the temperature on both edges of the fixing unit is much higher than the temperature on the center of the unit where the paper is fed depending on the setting or model. Therefore, the print speed is slowed in order to decrease the temperature on the edges after the specified time, it is maximum print speed when you first start printing.*
- *Max. speed is 12 ppm or more. It varies depending on the paper size.*

APPENDIX 4. HOW TO KNOW DRUM UNIT LIFE & PAGE COUNTER

If you want to know the drum unit life or the number of printed pages, you should print out the print configuration page.

NOTE:

The page counter and drum unit life are NOT printed on the Print Configuration page for some countries.

1. Print Configuration

- (1) Turn on the power switch while holding down the **Job Cancel** button.
- (2) Press the **2** key.
- (3) Print the Print Configuration page.

The page counter and drum counter are printed in the right upper corner of the Print Configuration page. (Refer to the figure below.) Note that the drum counter is an actual page counter after a new drum unit is replaced and may be different from the drum unit life shown in the drum life bar. For details, see [Section 2 'How to Read the Drum Unit Life'](#).

<Sample - HL-P2500>

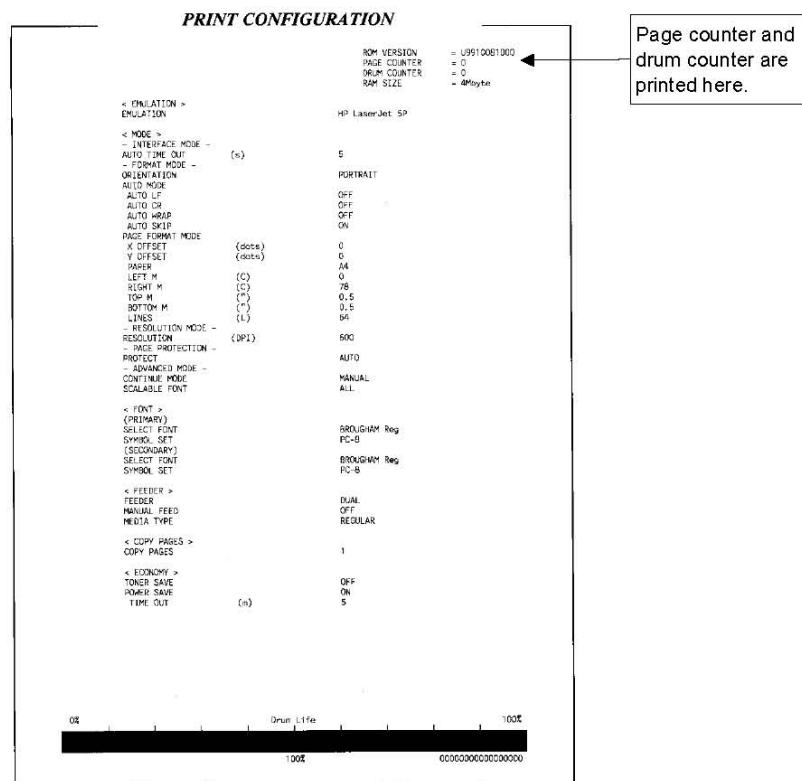

Fig. A-1

NOTE:

The descriptions printed in Print Configuration vary depending on the printer model or country.

2. How to Read the Drum Unit Life

The drum unit life is shown by the bar at the bottom of Print Configuration or Test Print as follows;

- It initially indicates 100% and gradually decreases.
- It indicates 0% when the Drum LED is on.
- It stays at 0% even if further printing is done.



Fig. A-2

The drum unit life is based on the page counter. If the average number of drum rotations is more than the number of drum rotations in non-continuous printing, however, the drum unit life is counted by the number of drum rotations.

Since the drum counter printed in the Print Configuration page is an actual page count after a new drum unit is replaced, the drum unit life may be different from the drum counter.

For details on the difference between the drum unit life and drum counter, refer to the drum unit life calculation below;

<How to calculate drum unit life>

**Printing time for 1 page/job in discontinuous printing = 14 seconds

(Page counter reduced by the number of drum rotations) = (Time of motor rotation) ÷ (14 sec.)

Example:

	Cold start (Idling for 6 sec.)	Hot start	Page counter
1 page/job	$(6 + 14) / 14 = 1.43$	$14 / 14 = 1$	1
2 pages/job	$(6 + 14 + 5) / 14 = 1.79$	$(14 + 5) / 14 = 1.36$	2
16 pages/job	$(6 + 14 + 5 \times 15) / 14 = 6.79$	$(14 + 5 \times 15) / 14 = 6.36$	16

If printing 1 page per job with cold start, the drum unit life is decreased earlier.

NOTE:

For information on how to understand the numbers on the right below the bar, see the following sections, '3. How to Read the Page Counter'.

3. How to Read the Page Counter

The page counter is shown at the right hand upper corner on the Print Configuration page.

It is also shown in the upper line on the right below the drum life bar and indicates the number of printed pages in units of 1 and 1,000.

- Value in units of 1

The hexadecimal value stored in NV-RAM is printed.

Example:

000000E0D0D0D0D0D

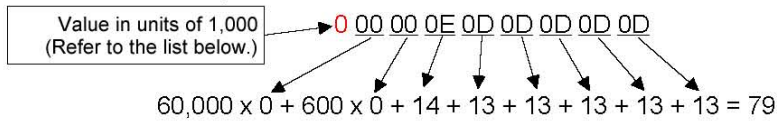

- Value in units of 1,000

Page counter indicated by units of 1,000 pages.

→ 0 - 99 pages	0	600 - 699 pages	6
100 - 199 pages	1	700 - 799 pages	7
200 - 299 pages	2	800 - 899 pages	8
300 - 399 pages	3	900 - 999 pages	9
400 - 499 pages	4	1,000 - 1,999 pages	A
500 - 599 pages	5	2,000 - 2,999 pages	B

APPENDIX 5. NVRAM DEFAULT VALUE

The default values for the main items to be set in NVRAM are as follows;

Items	Descriptions
Timing when the 'CHANGE DRUM SOON' message is displayed.	16,000 page (Counted from the drum unit life.)
Development switching timing	The developing bias is switched from 475V to 375V when 3,000 pages are printed. (Counted from the number of the drum rotation in non-continuous printing)
Fixing temperature	<ul style="list-style-type: none"> • Transparency: 163°C • Thin paper: 183°C • Regular paper: 195°C • Thick paper: 215°C • Thicker/Bond paper: 215°C (in non-continuous printing)
Smaller size mode	See APPENDIX 3 'PRINT SPEEDS WITH VARIOUS SETTINGS' .

APPENDIX 6. PAPER CASSETTE INFORMATION (FOR EUROPE ONLY)

The A4 size paper cassette fitted to the printer is different from the service manual information for printers shipped to Europe as follows:-

- 1) The paper cassette supplied with the HL-P2500 printer has a plastic rib on the paper tray cover.
- 2) The plastic rib is removed from the tray cover for the paper cassette supplied with the LT-400, (optional Lower Tray Unit) as shown on the right;

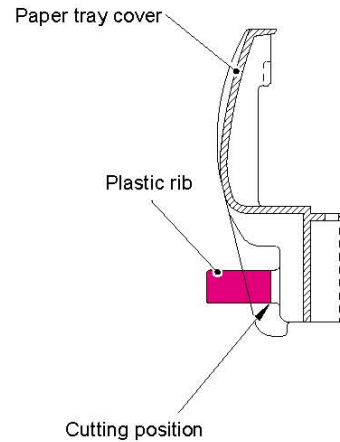
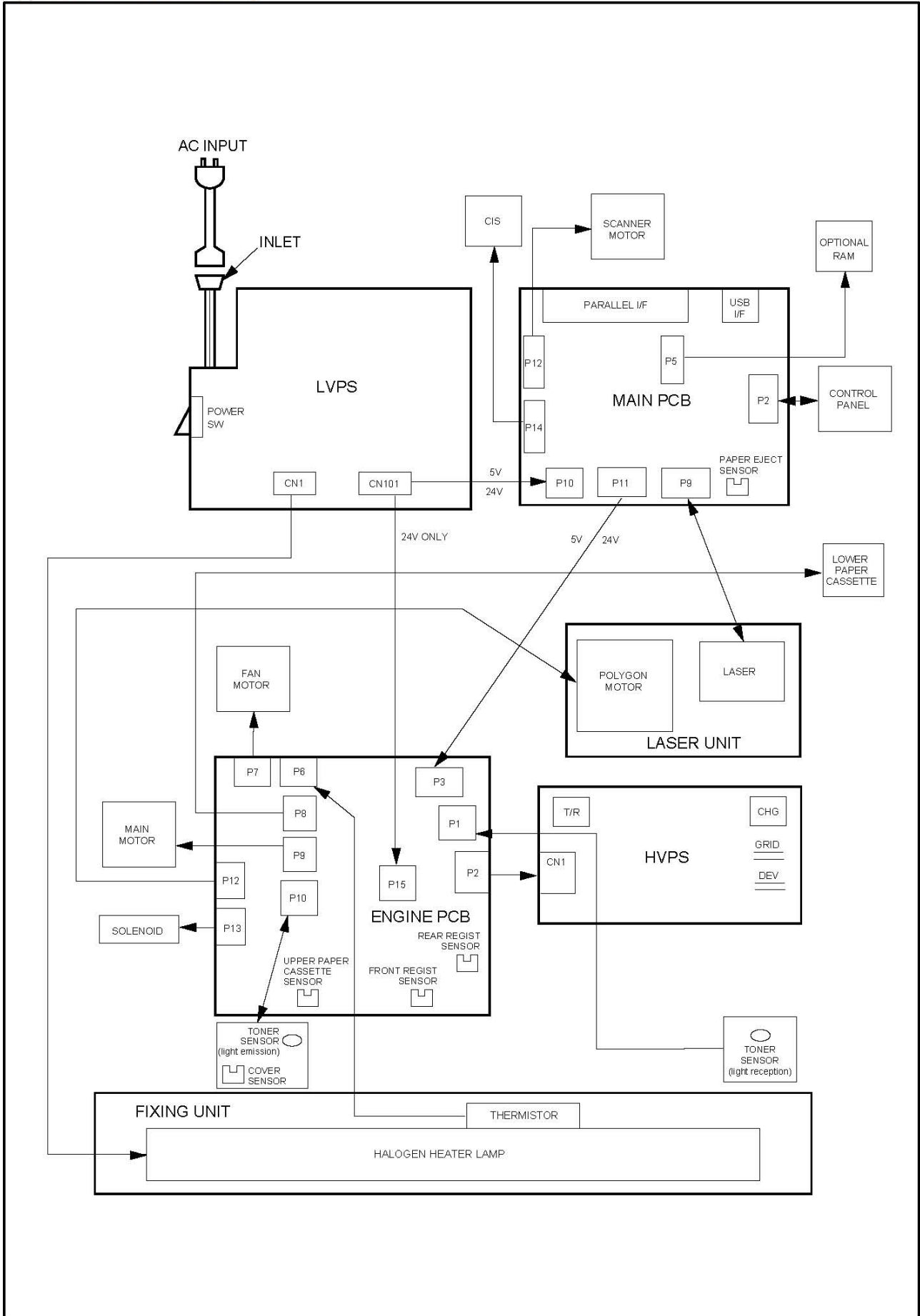

Fig. A- 3

- 3) If the optional LT-400 Lower Tray Unit is installed onto the HL-P2500 printer, it is necessary to exchange the cassette supplied with the LT-400 Unit with the upper cassette already fitted into the printer. Install the cassette originally fitted in the printer into the LT-400 Unit. Failure to do so will cause paper jams as the paper cannot be fed from the lower cassette to the printer body because the plastic rib on the paper tray cover is blocking the paper path.
- 4) For paper cassettes supplied as spare parts, the plastic rib has been cut off so that you can use it as both an upper cassette and lower cassette.

Appendix 7. Connection Diagram



Appendix 8. Main PCB Circuit Diagram (1/3)

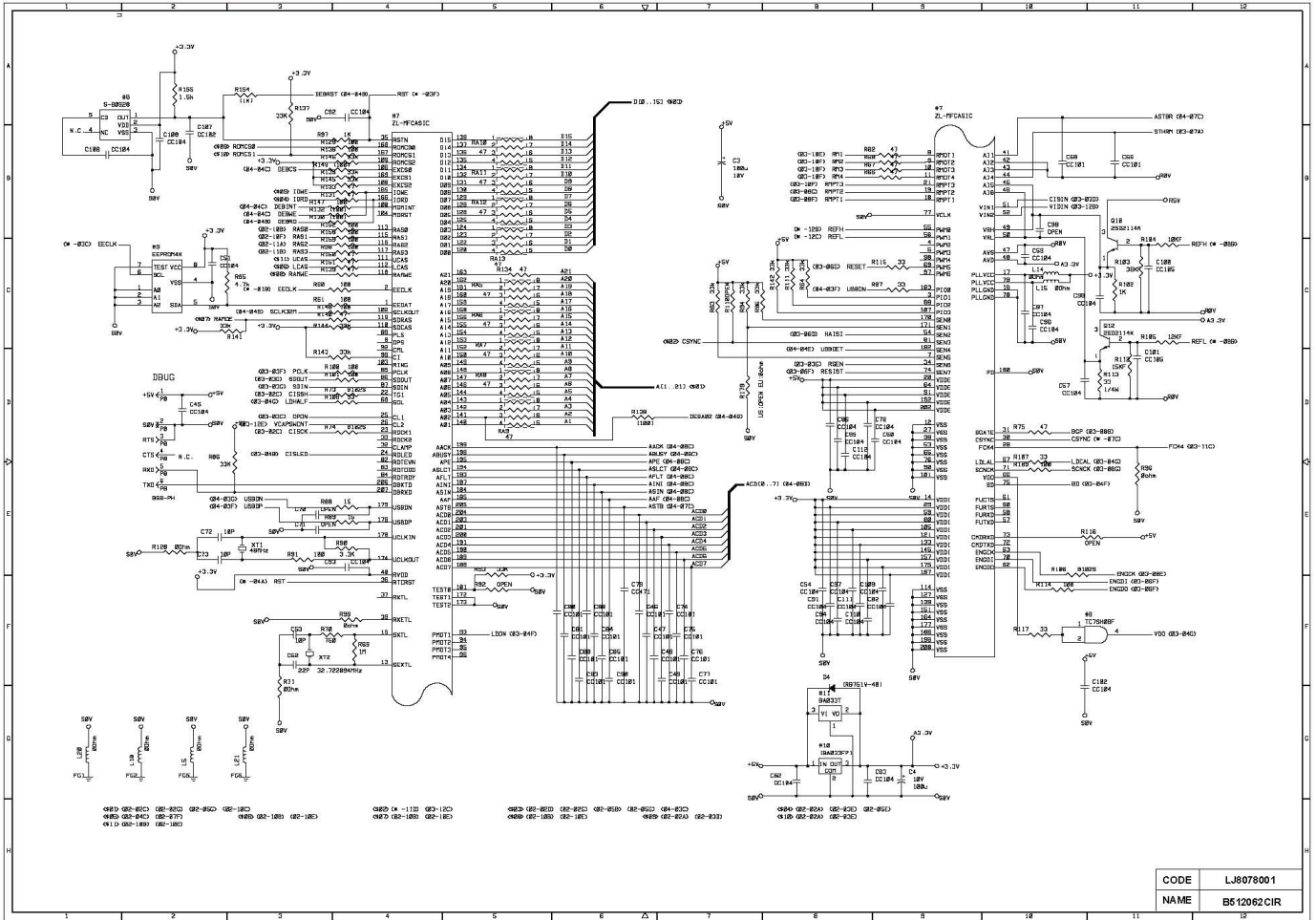

CODE	LJ8078001
NAME	BS12062 CIR

Appendix 9. Main PCB Circuit Diagram (2/3)

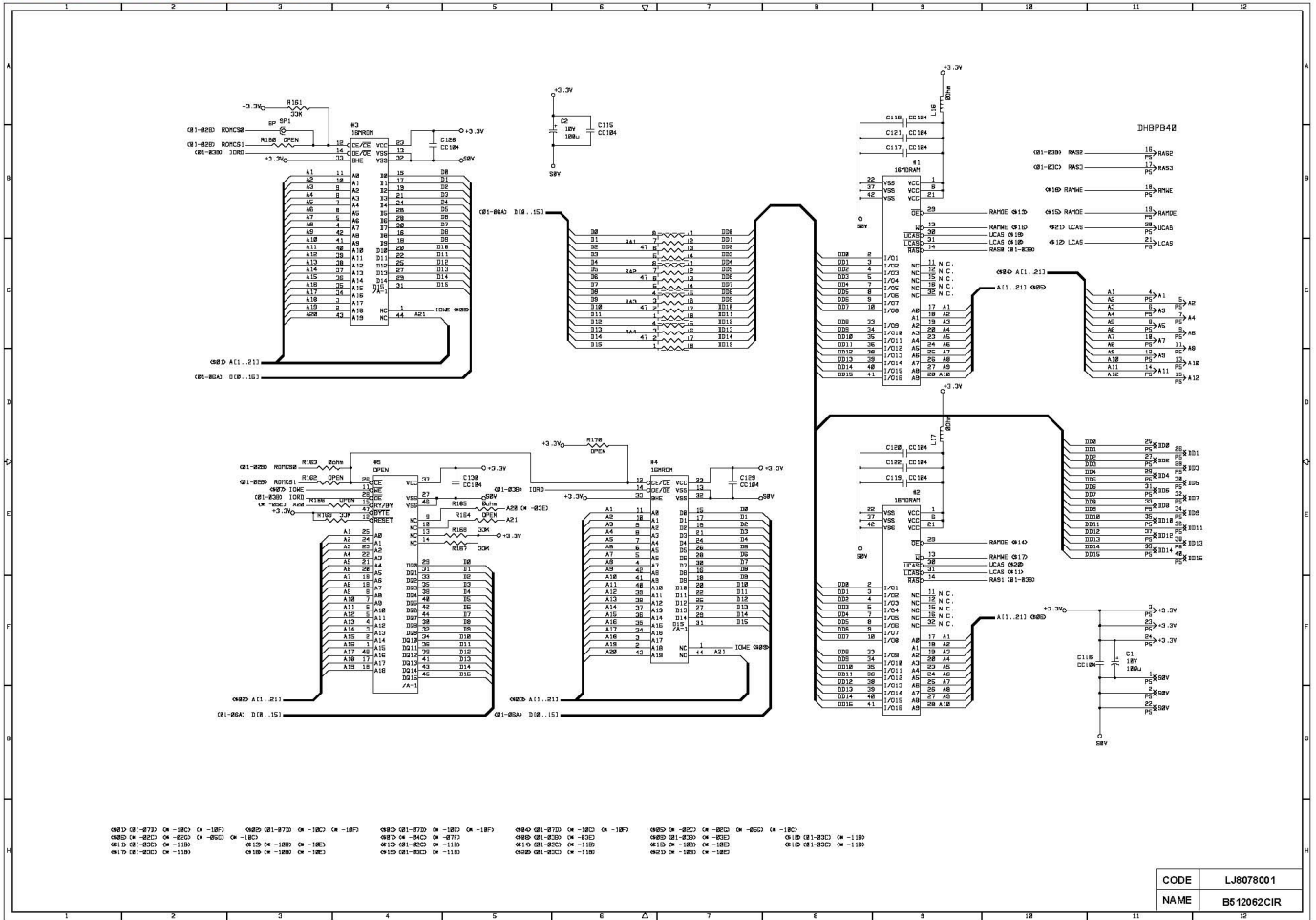

Appendix 10. Main PCB Circuit Diagram (3/3)

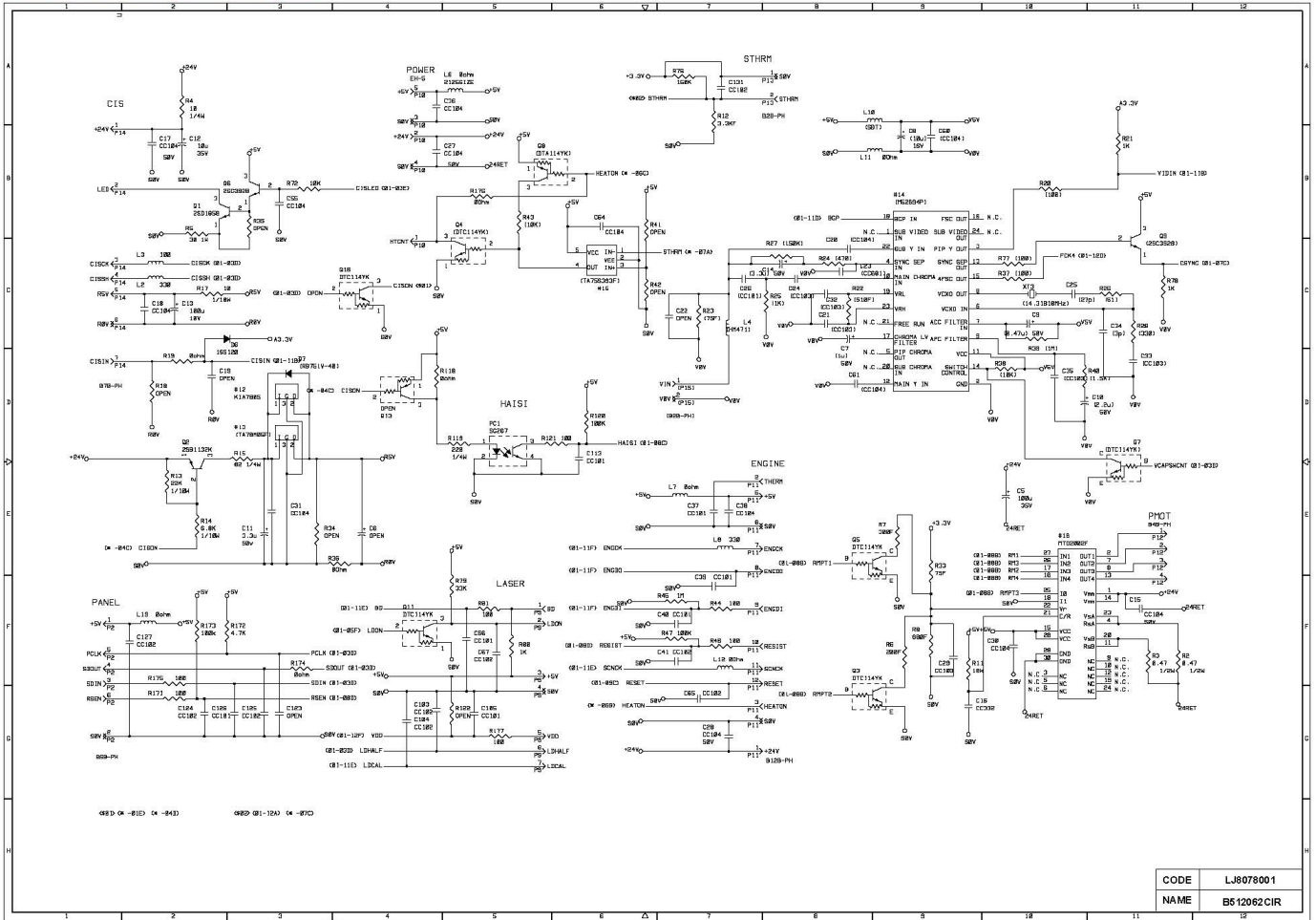

Appendix 11. Engine PCB Circuit Diagram

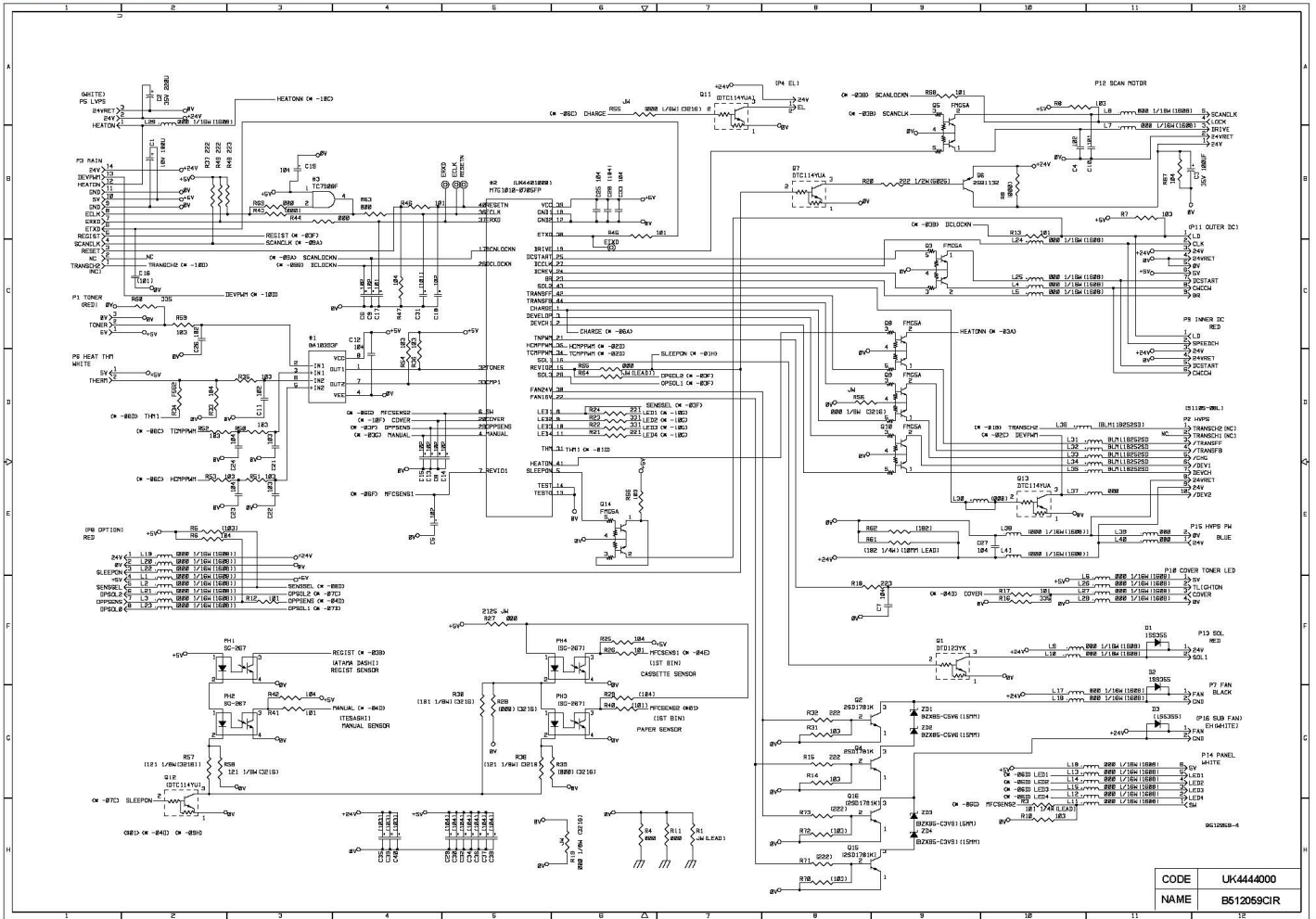

CODE	UK444000
NAME	B512059CIR

Appendix 12. Control Panel PCB Circuit Diagram

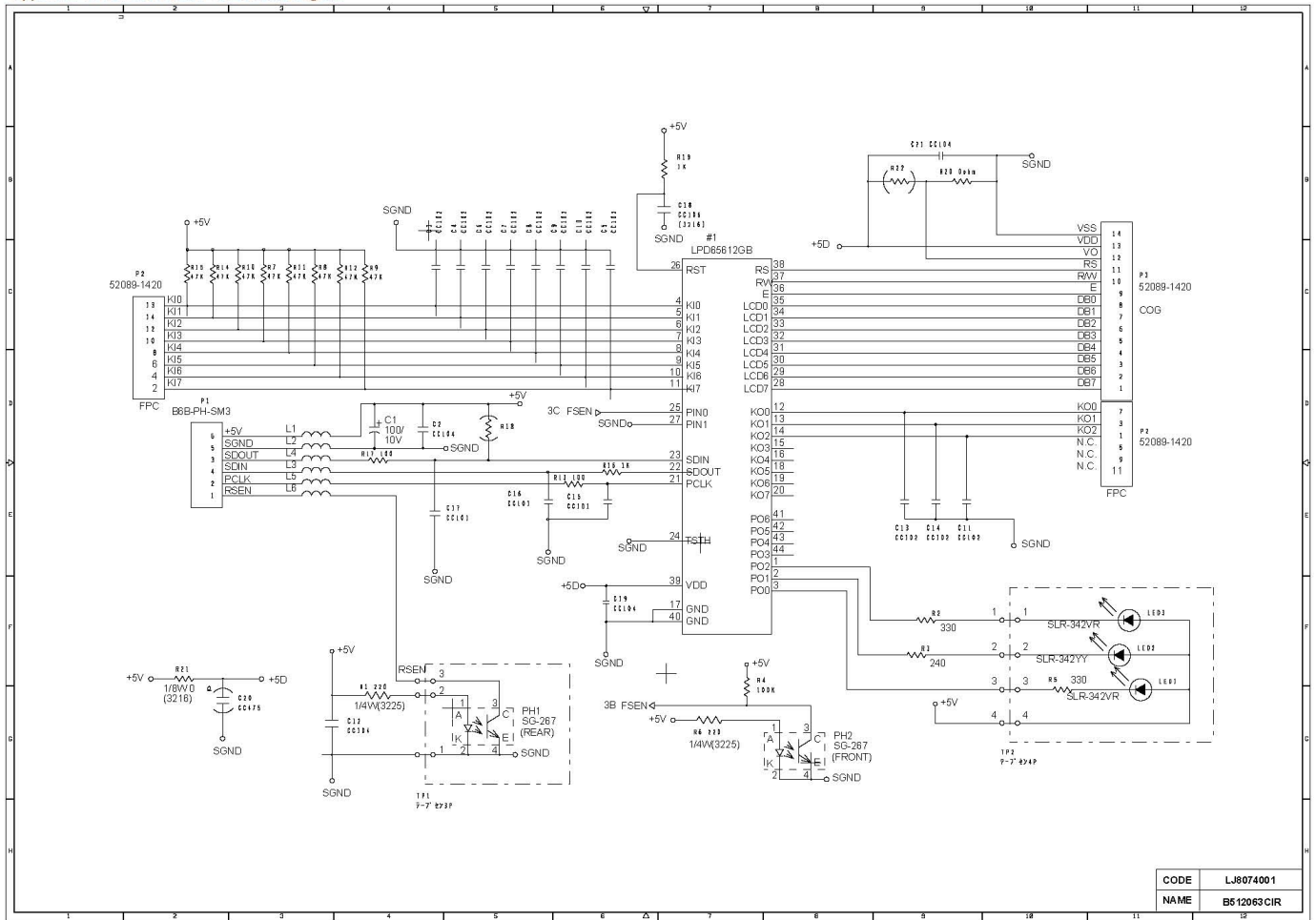

CODE	LJ8074001
NAME	B512063 CIR

Appendix 13. Low-voltage Power Supply PCB Circuit Diagram (110 - 120V)

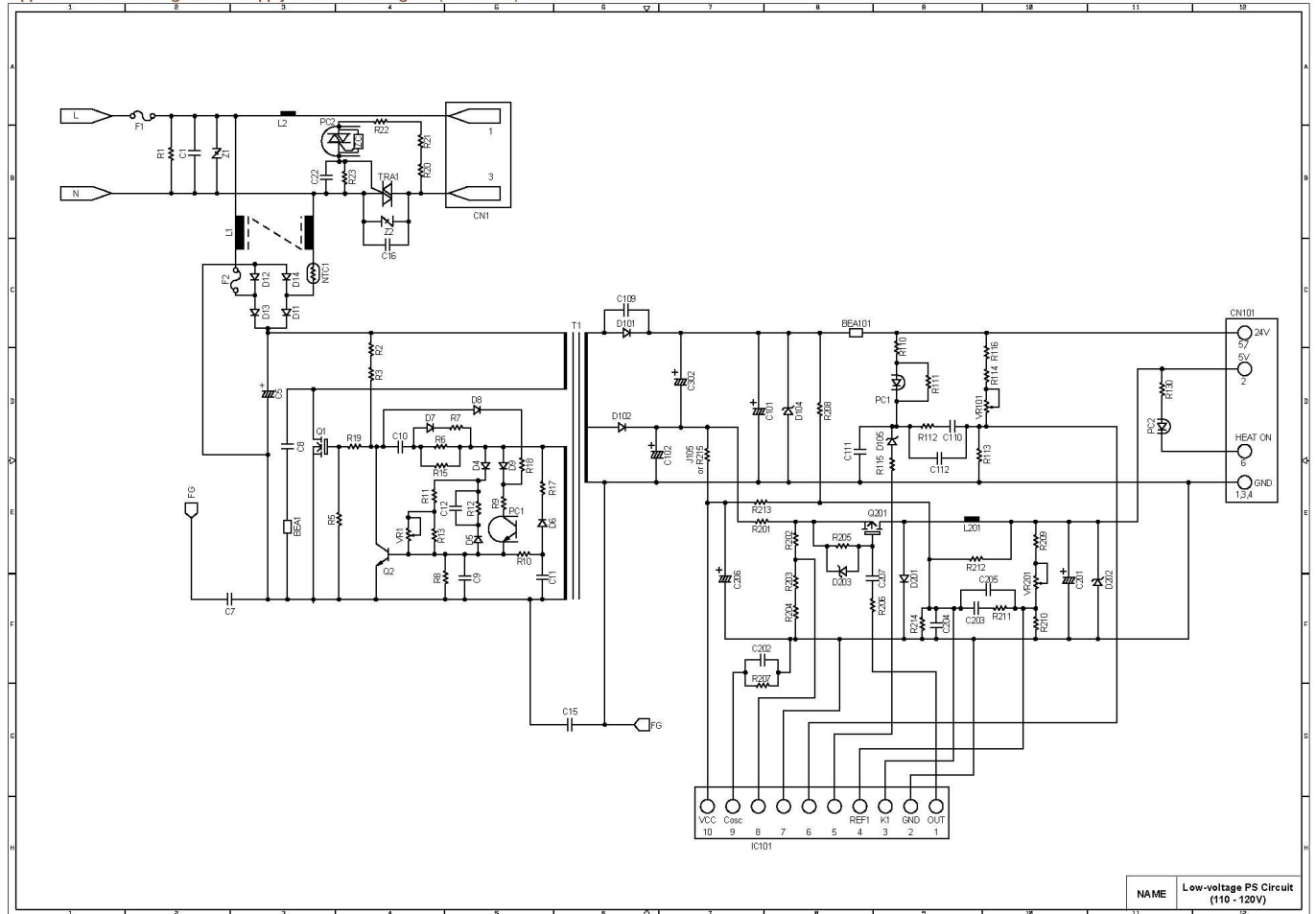

NAME	Low-voltage PS Circuit (110 - 120V)
------	-------------------------------------

Appendix 14. Low-voltage Power Supply PCB Circuit Diagram (220 - 240V)

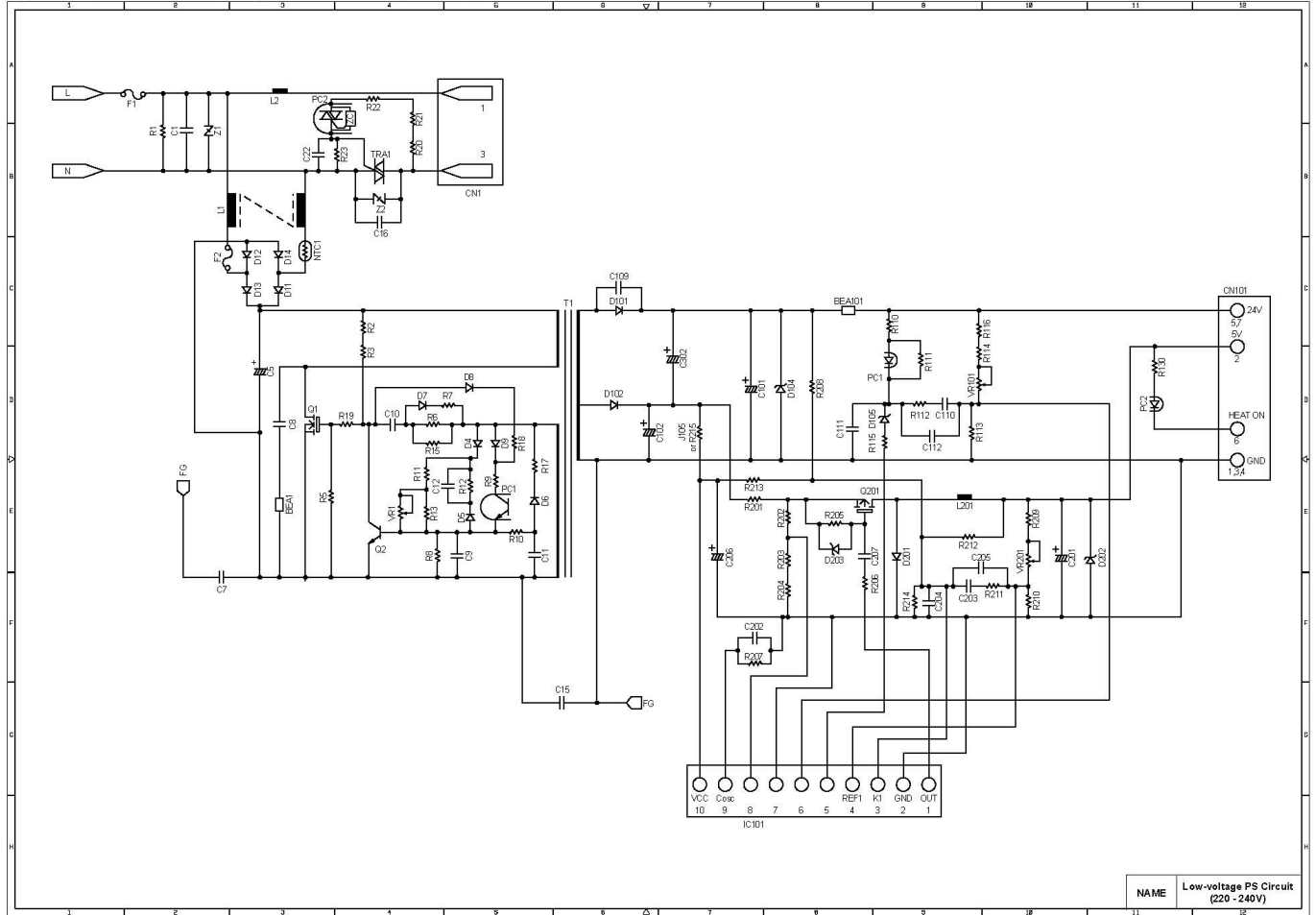

NAME Low-voltage PS Circuit (220 - 240V)

Appendix 15. High-voltage Power Supply PCB Circuit Diagram

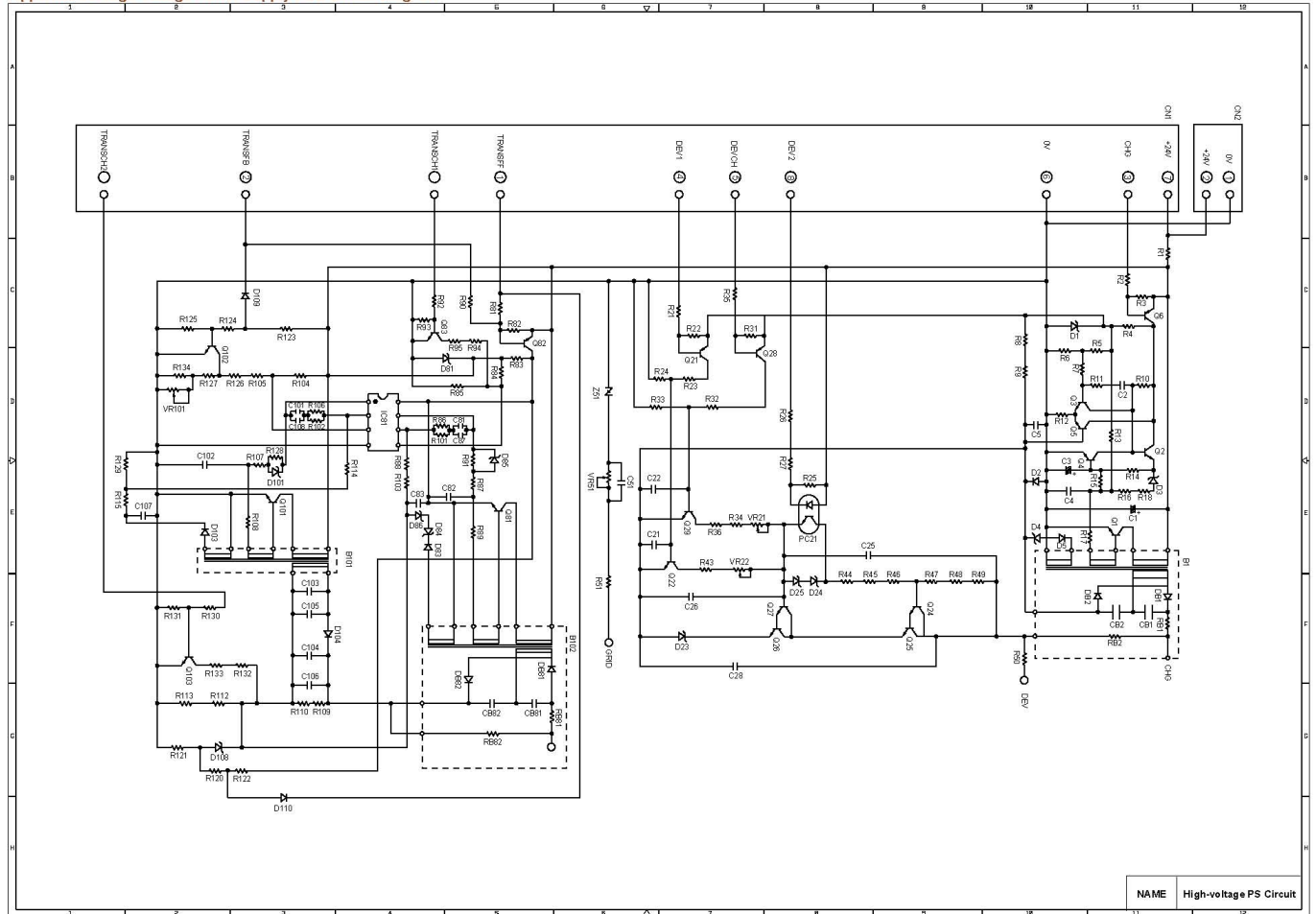

NAME	High-voltage PS Circuit
------	-------------------------

INDEX

1

10 keys 2-13

A

AC cord 4-3
 AC inlet ASSY 4-41
 AC power inlet 1-4
 ADF 1-4, 3-20
 capacity 1-12
 ADF performance test 6-5
 ADF spring 4-11
 Alarm LED 2-12
 all black 7-30
 anti-static brush 4-11
 ASIC 3-3
 automatic document feeder 1-4, 3-20

B

bar code 1-2
 base plate 4-37
 black band 7-42
 black horizontal stripes 7-33
 black spots 7-42
 black vertical streaks 7-32
 black vertical streaks (in a gray background)
 7-34
 blurred horizontal stripes 7-33
 blurred vertical streaks 7-32
 button 2-13

C

cassette cover film 4-5
 cassette pressure roller 4-6
 CHANGE DRUM SOON 7-4
 CHECK CASSETTE 7-4
 CHECK PAPER 7-4, 7-8
 circumference A-3
 CIS 3-13, 3-20
 CIS drive circuit 3-8
 CIS harness 4-15
 CIS scanner area 6-8
 CIS spring 4-16
 CIS unit 3-12, 4-16

CLEAN UP SCANNER 7-5
 cleaner 3-16
 cleaner spring 4-34
 cleaning 5-5
 Clear button 2-13
 completely blank 7-29
 component 2-2
 condensation 7-1
 consumable parts 5-1, 7-1
 contact image sensor unit 3-20
 control panel 1-4, 1-6, 2-12
 control panel ASSY 4-10
 control panel PCB 3-9, 3-13, 4-12
 operation check 6-6
 COOLING DOWN 7-5
 copy 2-17
 Copy button 2-13
 copy resolution 1-6
 copy setting 2-18
 copy speed 1-6
 copying operations 2-17
 corona wire 3-16
 COVER OPEN 7-4, 7-8
 cover sensor 3-15
 CPU 1-6
 creases 7-13
 curl 7-14

D

dark 7-28
 Data LED 2-12
 demo printer 6-1
 density 2-19
 Density button 2-13
 developing 3-18
 development roller 3-12, 3-18
 diameter A-3
 dimensions 1-7
 dirt on the back of paper 7-31
 disassembly
 flow 4-2
 document
 output capacity 1-12
 problem 7-15
 specification 1-12
 type 1-12

document delivery	1-12
document eject roller	3-20, 4-14
document eject pinch roller	4-14
document feed roller	3-20, 4-14
document front sensor	3-20
document front sensor actuator	4-12
document guide L	4-23
document guide R	4-23
DOCUMENT JAM	7-4
document nip piece	4-11
document output flap	1-4
document pick-up roller	3-20, 4-18
document pressure bar	3-20, 4-11
document pressure roller	4-18
document rear sensor	3-20
document rear sensor actuator	4-11
document scanner frame	4-15
document separation roller	4-18
document support	1-4
document type	2-18
Document Type button	2-13
double feeding	7-13
DOWNLOAD FULL	7-5
downward fogging of solid black	7-44
DRAM	3-5
drive unit	4-26
drum unit	4-3
cleaning	5-5, 7-41
ground contact	7-47
life	1-5, 5-1, 6-1, A-6
drum counter	A-5

E

economy mode	1-3
EEPROM	3-5
effective printing area	1-10
eject pinch roller	4-36
eject sensor	3-15
eject sensor lever	3-12
electrical terminal	
cleaning	5-6
emulation	1-2, 1-6
engine interface	3-6
ENGINE INTERFACE ERROR	7-8
engine PCB	3-9, 3-13, 4-43
Enlarge/Reduce button	2-13
enlargement	2-18
envelope	1-8
environment	2-1, 7-1

error code	6-9
error message	7-4
operator call	7-4
printouts	7-9
service call	7-6
status monitor	7-8

F

face-down	1-9
face-up	1-9
FACTORY RESET	6-1
faint print	7-39
fan motor	4-47
faulty registration	7-36
first eject roller	3-15, 4-36
first print	1-5
fixing unit	3-12, 4-28
FPC key	4-12
front cover	1-4, 4-20
front registration sensor	3-14
front registration sensor lever	3-12
front spring plate	4-11
function key	4-13
FUSER MALFUNCTION	7-8

G

general block diagram	3-1
ghost	7-45
gray background	7-43
grease	4-51
grid	3-16
ground contact	7-47

H

halogen heater lamp	4-31
heat roller	3-12, 3-19, 4-32
heat roller cleaner	4-34
HEX DUMP	6-1
high-voltage power supply	3-11
high-voltage power supply PCB	3-13, 4-42
hollow print	7-43
horizontal lines	7-44
humidity	1-7

I

IEEE1284	3-3
image defect	7-25

- all black 7-30
black band 7-42
black horizontal stripes 7-33
black spots 7-42
black vertical streaks 7-32
black vertical streaks (in a gray background)
..... 7-34
blurred horizontal stripes 7-33
blurred vertical streaks 7-32
completely blank 7-29
dark 7-28
dirt on the back of paper 7-31
downward fogging of solid black 7-44
examples 7-25
faint print 7-39
faulty registration 7-36
ghost 7-45
gray background 7-43
hollow print 7-43
horizontal lines 7-44
image distortion 7-38
light 7-27
light rain 7-45
poor fixing 7-37
toner specks 7-46
troubleshooting 7-26
white horizontal stripes 7-36
white spots 7-40
white vertical streaks 7-35
image distortion 7-38
incorrect printout 7-48
installation
printer 2-3
USB driver 2-5
interface 1-6
-
- J**
- jig 4-31, 4-38
Job Cancel button 2-13
-
- L**
- label 1-8
LASER BD MALFUNCTION 7-8
laser unit 3-13, 4-25
layout 2-19
LCD 2-14, 4-13
operation check 6-6
LED 2-12
- light 7-27
light rain 7-45
link 4-27
lock lever 4-8
low-voltage power supply 3-10
low-voltage power supply PCB 3-13, 4-41
lower tray relay PCB 4-40
-
- M**
- main PCB 3-3, 3-13, 4-39
block diagram 3-2
main cover 4-23
main motor 4-26
MAIN MOTOR ERROR 7-8
maintenance function 6-2
maintenance mode 6-2
malfunction 7-20
manual duplex 2-10
MANUAL FEED 7-5
manual feed paper guide 1-4
manual feed slot 1-4, 2-9
memory 1-6
MEMORY FULL 7-5, 7-8
MTBF 5-8
MTTR 5-8
-
- N**
- nip-related parts 3-20
NO DOCUMENT 7-4
noise 1-7
normal paper 1-8
NVRAM A-8
-
- O**
- OCR software 1-5
operator call 7-4
Options button 2-13
organizer 1-8
output tray 1-4
-
- P**
- packing 4-55
page counter A-5, A-7
page skew 7-14
panel harness 4-10
panel rear cover 4-12
paper 1-8, 7-1

- basis weight 1-8
 caliper 1-8
 jam 7-11
 loading 2-9
 moisture content 1-8
 problem 7-10
 recommended 1-8
 size 1-8
 type 1-8
 paper cassette 1-4, 2-9, 4-4, A-9
 capacity 1-9
 paper cassette cover 4-5
 paper feed roller 3-12, 3-14, 4-50
 paper indicator 1-4, 4-9
 PAPER JAM 7-8, 7-11
 paper pick-up roller 3-12, 4-49
 PaperPort® for Brother Software 1-1, 1-5, 2-20
 paper rear guide 4-8
 paper size 2-19
 Paper size button 2-13
 parallel interface 1-4
 parameter 6-3
 periodical replacement parts 5-4
 photosensitive drum 3-12, 3-16
 pick-up roller 3-14
 pinch roller 4-24
 PLS CLEAN DRUM 7-5
 PLS OPEN COVER 7-5
 polygon mirror 3-12
 poor fixing 7-37
 power consumption 1-7
 power source 1-7
 power supply 2-1, 3-10
 power switch 1-4
 PRESS STOP KEY 7-5
 pressure plate 3-12, 4-7
 pressure plate spring 4-7
 pressure roller 3-12, 3-19
 cleaning 7-31
 pressure roller cleaner 4-34
 pressure roller holder 4-6
 pressure roller leaf spring 4-18
 pressure roller shaft 4-6
 PRINT CONFIG 6-1
 Print Configuration A-5
 print delivery 1-9
 PRINT FONTS 6-1
 print guaranteed area 1-10
 print method 1-5
 print quality 1-5
 print resolution 1-5
 print speed 1-1, 1-5, A-4
 printer driver 1-1, 1-6
 PRINTER JAM 7-4
 printer status monitor 1-2
 Printout 7-9
-
- Q**
- Quick Print Setup 1-2
-
- R**
- rear cover 1-4, 4-24
 rear registration sensor 3-14
 rear registration sensor lever 3-12
 recommended paper 1-8
 reduction 2-18
 Remote Printer Console 1-2
 reset IC 3-6
 resolution 1-1
 RESOLUTION ADAPTED 7-9
 ROM 3-4
 RPC 1-2
 rubber holder 4-11
-
- S**
- scaling 1-6
 scan method 1-5
 scan resolution 1-5
 Scan to Email button 2-13
 Scan to File button 2-13
 scannable area 1-13
 scanner drive unit 4-17
 scanner driver 1-2
 SCANNER ERROR 7-5
 scanner ground plate 4-21
 SCANNER MALFUNCTION 7-8
 scanner motor 3-12, 4-17
 scanner motor drive circuit 3-7
 scanner motor harness 4-15
 scanner panel interface 3-7
 scanner window
 cleaning 5-6
 scanning compensation 6-3
 scanning operations 2-20
 scanning unit
 cleaning 5-7
 second eject roller 3-12, 3-15, 4-22

sensor
 operation check 6-7
 checking..... 7-12
 separation pad..... 3-12, 3-14
 separation pad holder..... 4-4
 separation pad spring..... 4-4
 separation roller..... 3-20
 separation rubber 4-11
 serial number A-1
 service call..... 7-6
 side guide gear..... 4-9
 side guide L..... 4-7
 side guide R..... 4-7
 side guide rack 4-9
 sleep mode..... 1-3
 software setting 7-17
 solenoid 4-46
 sort 2-19
 Sort button..... 2-13
 sponge holder..... 4-6
 sponge holder spring..... 4-6
 stack 2-19
 Stop button..... 2-13
 straight paper path 2-10
 supply roller..... 3-18
 system requirement..... 2-1

T

temperature..... 1-7
 test pattern 6-5
 TEST PRINT 6-1
 test print mode..... 2-16, 6-1
 thermistor 3-19, 4-35
 toner cartridge 3-16
 life 1-5, 5-2
 TONER EMPTY 7-4, 7-8
 Toner LED..... 2-12
 TONER LOW..... 7-4, 7-8
 toner sensor 3-12, 3-16
 toner sensor PCB
 light emission 4-48
 light reception..... 4-48
 toner specks 7-46
 top cover..... 4-22
 torque values..... 4-1
 transfer 3-19
 transfer roller 3-16, 3-19
 transparency..... 1-8
 tray extension flap 1-4, 4-24

T/R electrode helical spring 4-42
 TWAIN compliant applications 2-21
 TWAIN compliant scanner driver 2-21
 TWAIN driver 1-5

U

Unimessage™ Pro Viewer..... 2-20
 unpacking 2-2
 USB..... 1-6
 USB interface..... 1-2, 1-4, 3-3
 USB interface cable 2-5

W

warm-up..... 1-5
 warning 7-2
 wave 7-14
 weight..... 1-7
 white horizontal stripes 7-36
 white spots 7-40
 white vertical streaks 7-35
 WordCraft Unimessage™ Pro Viewer 1-1, 1-5
 wrinkles..... 7-13